

PLASTIC ANALYSIS

1.0 INTRODUCTION

The elastic design method, also termed as *allowable stress method (or Working stress method)*, is a conventional method of design based on the elastic properties of steel. This method of design limits the structural usefulness of the material upto a certain allowable stress, which is well below the elastic limit. The stresses due to working loads do not exceed the specified allowable stresses, which are obtained by applying an adequate factor of safety to the yield stress of steel. The elastic design does not take into account the strength of the material beyond the elastic stress. Therefore the structure designed according to this method will be heavier than that designed by plastic methods, but in many cases, elastic design will also require less stability bracing.

In the method of plastic design of a structure, the ultimate load rather than the yield stress is regarded as the design criterion. The term *plastic* has occurred due to the fact that the ultimate load is found from the strength of steel in the plastic range. This method is also known as *method of load factor design* or *ultimate load design*. The strength of steel beyond the yield stress is fully utilised in this method. This method is rapid and provides a rational approach for the analysis of the structure. This method also provides striking economy as regards the weight of steel since the sections designed by this method are smaller in size than those designed by the method of elastic design. Plastic design method has its main application in the analysis and design of statically indeterminate framed structures.

2.0 BASIS OF PLASTIC THEORY

2.1 Ductility of Steel

Structural steel is characterised by its capacity to withstand considerable deformation beyond first yield, without fracture. During the process of 'yielding' the steel deforms under a constant and uniform stress known as 'yield stress'. This property of steel, known as *ductility*, is utilised in plastic design methods.

Fig. 1 shows the idealised stress-strain relationship for structural mild steel when it is subjected to direct tension. Elastic straining of the material is represented by line *OA*. *AB* represents yielding of the material when the stress remains constant, and is equal to the yield stress, f_y . The strain occurring in the material during yielding remains after the load has been removed and is called the plastic strain and this strain is at least ten times as large as the elastic strain, e_y at yield point.

© Copyright reserved

When subjected to compression, the stress-strain characteristics of various grades of structural steel are largely similar to Fig. 1 and display the same property of yield. The major difference is in the strain hardening range where there is no drop in stress after a peak value. This characteristic is known as *ductility of steel*.

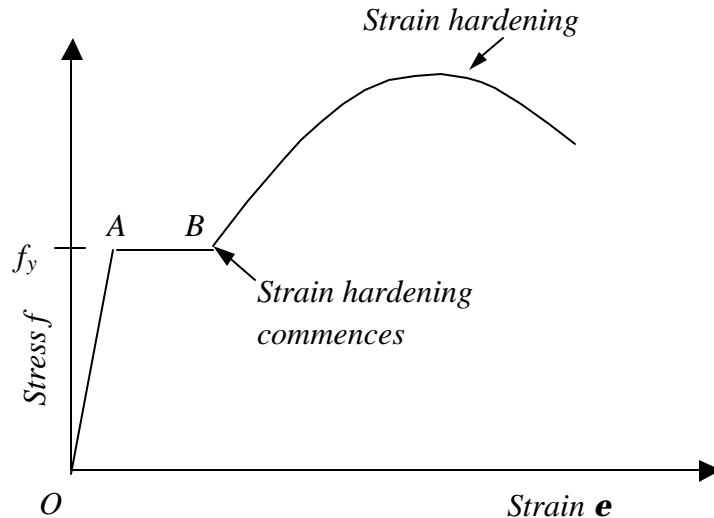

Fig. 1 Idealised stress – strain curve for steel in tension

2.2 Theoretical Basis

As an incremental load is applied to a beam, the cross-section with greatest bending moment will eventually reach the yield moment. Elsewhere the structure is elastic and the 'peak' moment values are less than yield. As load is incremented, a zone of yielding develops at the first critical section, but due to ductility of steel, the moment at that section remains about constant. The structure, therefore, calls upon its less heavily stressed portions to carry the increase in load. Eventually the zones of yielding are formed at other sections until the moment capacity has been exhausted at all necessary critical sections. After reaching the maximum load value, the structure would simply deform at constant load. Thus it is a design based upon the ultimate load-carrying capacity (maximum strength) of the structure. This ultimate load is computed from a knowledge of the strength of steel in the plastic range and hence the name 'plastic'.

2.3 Perfectly Plastic Materials

The stress-strain curve for a perfectly plastic material upto strain hardening is shown in Fig. 2. Perfectly plastic materials follow Hook's law upto the limit of proportionality. The slopes of stress-strain diagrams in compression and tension i.e. the values of Young's modulus of elasticity of the material, are equal. Also the values of yield stresses in tension and compression are equal. The strains upto the strain hardening in tension and compression are also equal. The stress strain curves show horizontal plateau both in tension and compression. Such materials are known as *perfectly plastic materials*.

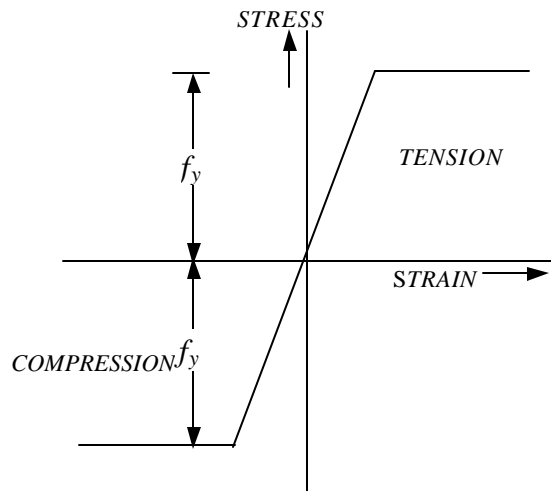

Fig. 2 Stress - Strain Curve for perfectly plastic materials

2.4 Fully Plastic Moment of a Section

The fully plastic moment M_p , of a section is defined as the maximum moment of resistance of a fully plasticized or yielded cross-section. The assumptions used for finding the plastic moment of a section are:

- (i) The material obeys Hooke's law until the stress reaches the upper yield value; on further straining, the stress drops to the lower yield value and thereafter remains constant.
- (ii) The yield stresses and the modulus of elasticity have the same value in compression as in tension.
- (iii) The material is homogeneous and isotropic in both the elastic and plastic states.
- (iv) The plane transverse sections (the sections perpendicular to the longitudinal axis of the beam) remain plane and normal to the longitudinal axis after bending, the effect of shear being neglected.
- (v) There is no resultant axial force on the beam.
- (vi) The cross section of the beam is symmetrical about an axis through its centroid parallel to plane of bending.
- (vii) Every layer of the material is free to expand and contract longitudinally and laterally under the stress as if separated from the other layers.

In order to find out the fully plastic moment of a yielded section of a beam as shown in Fig. 3, we employ the force equilibrium equation, namely the total force in compression and the total force in tension over that section are equal.

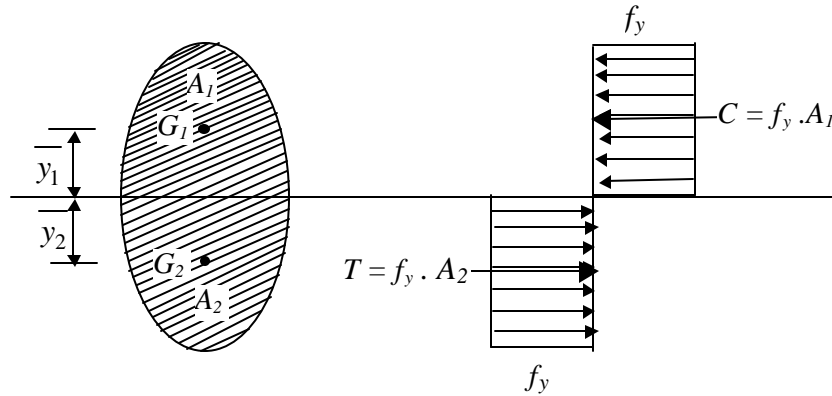

Fig. 3

Total compression , C = Total tension , T

$$\begin{aligned} f_y \cdot A_1 &= f_y \cdot A_2 \\ \backslash \quad A_1 &= A_2 \\ A &= A_1 + A_2 \\ A_1 &= A_2 = A/2 \end{aligned}$$

Plastic Moment of resistance, M_p = $f_y \cdot A_1 \cdot \bar{y}_1$ + $f_y \cdot A_2 \cdot \bar{y}_2$

$$= f_y \cdot \frac{A}{2} \cdot (\bar{y}_1 + \bar{y}_2)$$

$$= f_y \cdot Z_p \tag{1}$$

where Z_p , the plastic modulus of the section = $\frac{A}{2} \cdot (\bar{y}_1 + \bar{y}_2)$

The **plastic modulus** of a completely yielded section is defined as the combined statical moment of the cross-sectional areas above and below the neutral axis or equal area axis. It is the resisting modulus of a completely plasticised section.

3.0 BENDING OF BEAMS SYMMETRICAL ABOUT BOTH AXES

The bending of a symmetrical beam subjected to a gradually increasing moment is considered first. The fibres of the beam across the cross section are stressed in tension or compression according to their position relative to the neutral axis and are strained in accordance with Fig. 1.

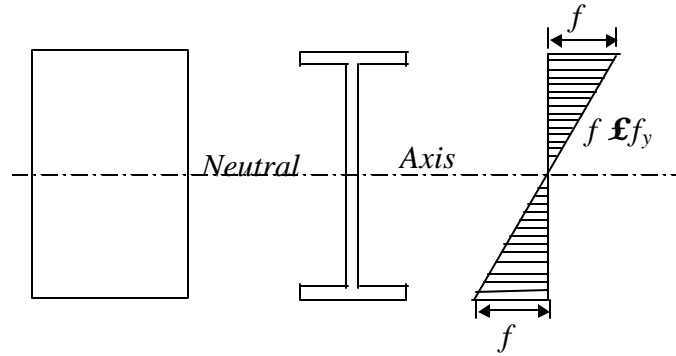

Fig. 4 Elastic stresses in beams

While the beam remains entirely elastic the stress in every fibre is proportional to its strain and to its distance from the neutral axis. The stress (f) in the extreme fibres cannot exceed f_y . (see Fig. 4)

When the beam is subjected to a moment slightly greater than that, which first produces yield in the extreme fibres, it does not fail. Instead the outer fibres yield at constant stress (f_y) while the fibres nearer to the neutral axis sustain increased elastic stresses. Fig. 5 shows the stress distribution for beams subjected to such moments.

Such beams are said to be 'partially plastic' and those portions of their cross-sections, which have reached the yield stress, are described as 'plastic zones'.

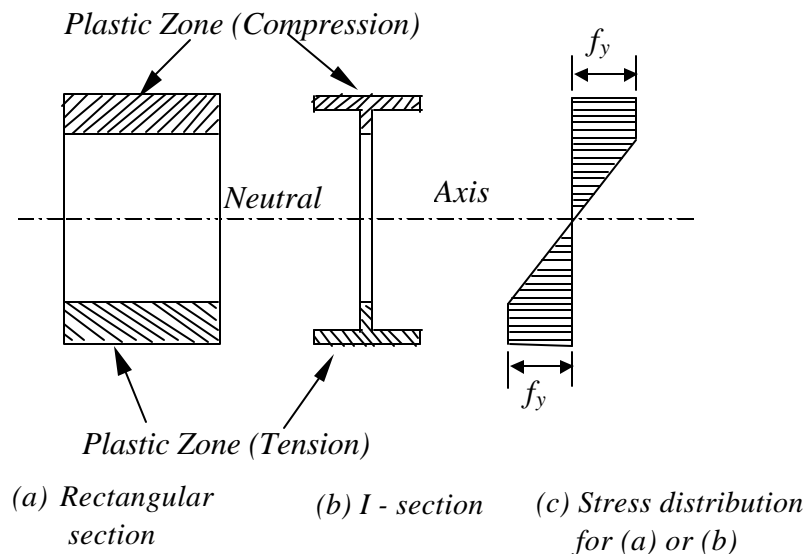

Fig. 5 Stresses in partially plastic beams

The depths of the plastic zones depend upon the magnitude of the applied moment. As the moment is increased, the plastic zones increase in depth, and, it is assumed that plastic yielding can occur at yield stress (f_y) resulting in two stress blocks, one zone yielding in tension and one in compression. Fig. 6 represents the stress distribution in beams stressed to this stage. The plastic zones occupy the whole of the cross section, and are described as being 'fully plastic'. When the cross section of a member is fully plastic under a bending moment, any attempt to increase this moment will cause the member to act as if hinged at the neutral axis. This is referred to as a *plastic hinge*.

The bending moment producing a plastic hinge is called the full *plastic moment* and is denoted by ' M_p '. Note that a plastic hinge carries a constant moment, M_p .

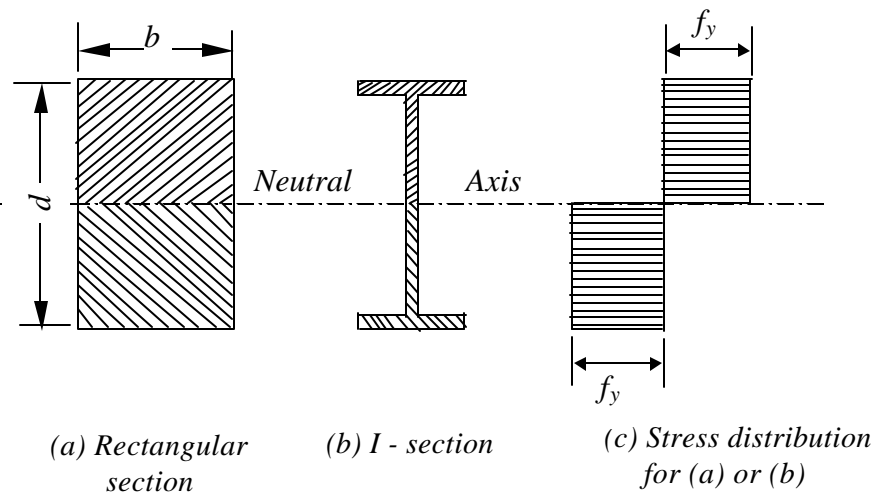

Fig. 6 Stresses in fully plastic beams

4.0 GENERAL REQUIREMENTS FOR UTILISING PLASTIC DESIGN CONCEPTS

Generally codes (such as IS 800, BS 5950) allow the use of plastic design only where loading is predominantly static and fatigue is not a design criterion.

For example, in order to allow this high level of strain, *BS 5950* prescribes the following restrictions on the properties of the stress-strain curve for steels used in plastically designed structures (clause 5.3.3).

1. The yield plateau (horizontal portion of the curve) is greater than 6 times the yield strain.
2. The ultimate tensile strength must be more than 1.2 times the yield strength.
3. The elongation on a standard gauge length is not less than 15%.

These limitations are intended to ensure that there is a sufficiently long plastic plateau to enable a hinge to form and that the steel will not experience a premature strain hardening.

4.1 Shape Factor

As described previously there will be two stress blocks, one in tension, the other in compression, both of which will be at yield stress. For equilibrium of the cross section, the areas in compression and tension must be equal. For a rectangular cross section, the elastic moment is given by,

$$M = \frac{bd^2}{6} f_y \tag{2.a}$$

The plastic moment is obtained from,

$$M_p = 2.b \cdot \frac{d}{2} \cdot \frac{d}{4} \cdot f_y = \frac{bd^2}{4} f_y \tag{2.b}$$

Here the plastic moment M_p is about 1.5 times greater than the elastic moment capacity. In developing this moment, there is a large straining in the extreme fibres together with large rotations and deflection. This behaviour may be plotted as a moment-rotation curve. Curves for various cross sections are shown in Fig. 7.

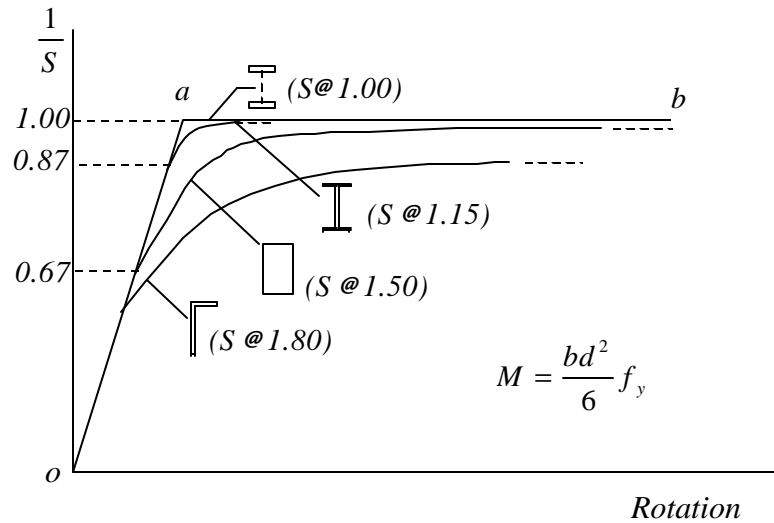

Fig.7 Moment – rotation curves

The ratio of the plastic modulus (Z_p) to the elastic modulus (Z) is known as the shape factor (S) and will govern the point in the moment-rotation curve when non-linearity starts. For the theoretically ideal section in bending i.e. two flange plates connected by a web of insignificant thickness, this will have a value of 1. When the material at the centre of the section is increased, the value of S increases. For a universal beam the value is about 1.15 increasing to 1.5 for a rectangle.

5.0 PLASTIC HINGES

In deciding the manner in which a beam may fail it is desirable to understand the concept of how plastic hinges form where the beam is fully plastic.

At the plastic hinge an infinitely large rotation can occur under a constant moment equal to the plastic moment of the section. Plastic hinge is defined as a yielded zone due to bending in a structural member at which an infinite rotation can take place at a constant plastic moment M_p of the section. The number of hinges necessary for failure does not vary for a particular structure subject to a given loading condition, although a part of a structure may fail independently by the formation of a smaller number of hinges. The member or structure behaves in the manner of a hinged mechanism and in doing so adjacent hinges rotate in opposite directions.

Theoretically, the plastic hinges are assumed to form at points at which plastic rotations occur. Thus the length of a plastic hinge is considered as zero.

The values of moment, at the adjacent section of the yield zone are more than the yield moment up to a certain length DL , of the structural member. This length DL , is known as the hinged length. The hinged length depends upon the type of loading and the geometry of the cross-section of the structural member. The region of hinged length is known as *region of yield* or *plasticity*.

5.1 Hinged Length of a Simply Supported Beam with Central Concentrated Load

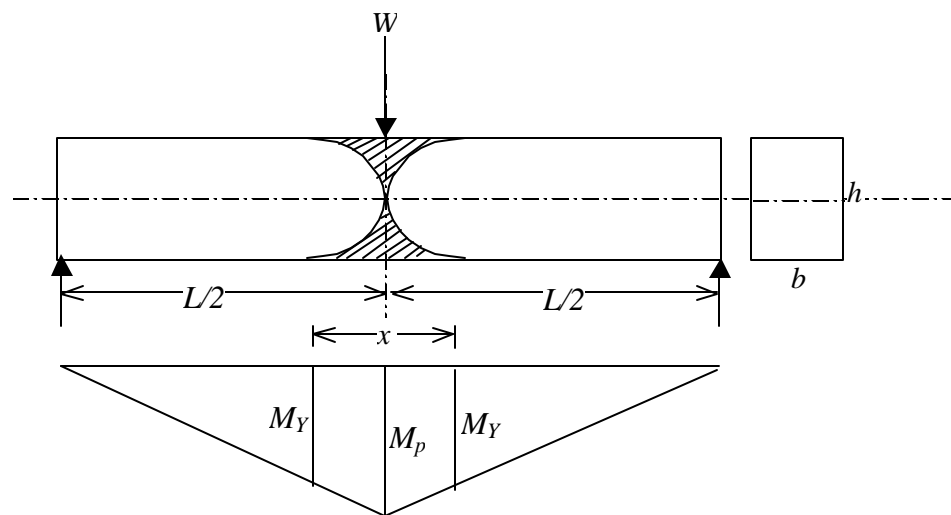

Fig. 8

In a simply supported beam with central concentrated load, the maximum bending moment occurs at the centre of the beam. As the load is increased gradually, this moment reaches the fully plastic moment of the section M_p and a plastic hinge is formed at the centre.

$$\begin{aligned}
 M_p &= \frac{Wl}{4} \\
 &= f_y \cdot \frac{bh^2}{4} \quad \left(\because Z_p = \frac{bh^2}{4} \right) \\
 M_y &= f_y \cdot \frac{bh^2}{6} = \left(f_y \cdot \frac{bh^2}{4} \right) \frac{2}{3} \\
 \therefore M_y &= \frac{2}{3} M_p
 \end{aligned}$$

Let x ($= DL$) be the length of plasticity zone.

From the bending moment diagram shown in Fig. 8

$$\begin{aligned}
 \frac{M_y}{\frac{L}{2} - \frac{x}{2}} &= \frac{M_p}{\frac{L}{2}} \\
 \frac{M_y}{M_p} &= \frac{\frac{L}{2} - \frac{x}{2}}{\frac{L}{2}} \\
 \frac{M_y}{M_p} &= 1 - \frac{x}{L} \\
 (L - x)M_p &= L \cdot M_y \\
 (L - x)M_p &= L \cdot \frac{2}{3} \cdot M_p \\
 x &= \frac{1}{3} L \quad (3)
 \end{aligned}$$

Therefore the hinged length of the plasticity zone is equal to one-third of the span in this case.

6.0 FUNDAMENTAL CONDITIONS FOR PLASTIC ANALYSIS

- (i) **Mechanism condition:** *The ultimate or collapse load is reached when a mechanism is formed. The number of plastic hinges developed should be just sufficient to form a mechanism.*
- (ii) **Equilibrium condition :** $\dot{a}F_x = 0, \dot{a}F_y = 0, \dot{a}M_{xy} = 0$

- (iii) **Plastic moment condition:** *The bending moment at any section of the structure should not be more than the fully plastic moment of the section.*

6.1 Mechanism

When a system of loads is applied to an elastic body, it will deform and will show a resistance against deformation. Such a body is known as a *structure*. On the other hand if no resistance is set up against deformation in the body, then it is known as a *mechanism*.

Various types of independent mechanisms are

6.1.1 Beam Mechanism

Fig. 9 sketches three simple structures and the corresponding mechanisms.

- (a) A simply supported beam has to form one plastic hinge at the point of maximum bending moment.
Redundancy, $r = 0$
- (b) A propped cantilever requires two hinges to form a mechanism.
Redundancy, $r = 1$
No. of plastic hinges formed,
 $= r + I = 2$
- (c) A fixed beam requires three hinges to form a mechanism.
Redundancy, $r = 2$
No. of plastic hinges $= 2 + I = 3$

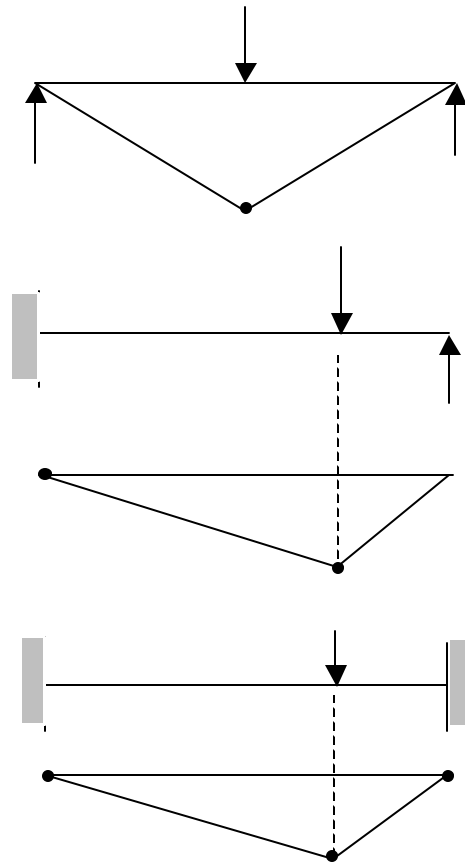

Fig. 9

From the above examples, it is seen that the number of hinges needed to form a mechanism equals the statical redundancy of the structure plus one.

6.1.2 Panel or Sway Mechanism

Fig. 10 (A) shows a panel or sway mechanism for a portal frame fixed at both ends.

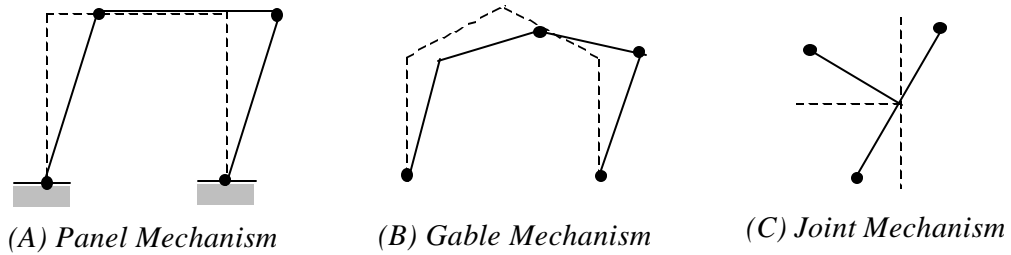

Fig. 10

6.1.3 Gable Mechanism

Fig. 10 (B) shows the gable mechanism for a gable structure fixed at both the supports.

6.1.4 Joint Mechanism

Fig. 10 (C) shows a joint mechanism. It occurs at a joint where more than two structural members meet.

6.1.5 Combined Mechanism

Various combinations of independent mechanisms can be made depending upon whether the frame is made of strong beam and weak column combination or strong column and weak beam combination. The one shown in Fig.11 is a combination of a beam and sway mechanism. Failure is triggered by formation of hinges at the bases of the columns and the weak beam developing two hinges. This is illustrated by the right hinge being shown on the beam, in a position slightly away from the joint.

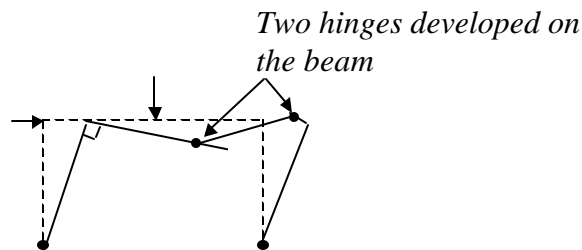

Fig. 11 Combined Mechanism

6.2 LOAD FACTOR AND THEOREMS OF PLASTIC COLLAPSE

Plastic analysis of structures is governed by three theorems, which are detailed in this section.

The load factor at rigid plastic collapse (\mathbf{I}_p) is defined as the lowest multiple of the design loads which will cause the whole structure, or any part of it to become a mechanism.

In a limit state approach, the designer is seeking to ensure that at the appropriate factored loads the structure will not fail. Thus the rigid plastic load factor \mathbf{I}_p must not be less than unity.

The number of independent mechanisms (n) is related to the number of possible plastic hinge locations (h) and the number of degree of redundancy (r) of the frame by the equation.

$$n = h - r \quad (4)$$

The three theorems of plastic collapse are given below for reference.

6.2.1 Lower Bound or Static Theorem

A load factor (\mathbf{I}_s) computed on the basis of an arbitrarily assumed bending moment diagram which is in equilibrium with the applied loads and where the fully plastic moment of resistance is nowhere exceeded will always be less than or at best equal to the load factor at rigid plastic collapse, (\mathbf{I}_p).

\mathbf{I}_p is the highest value of \mathbf{I}_s which can be found.

6.2.2 Upper Bound or Kinematic Theorem

A load factor (\mathbf{I}_k) computed on the basis of an arbitrarily assumed mechanism will always be greater than, or at best equal to the load factor at rigid plastic collapse (\mathbf{I}_p)

\mathbf{I}_p is the lowest value of \mathbf{I}_k which can be found.

6.2.3 Uniqueness Theorem

If both the above criteria are satisfied, then the resulting load factor corresponds to its value at rigid plastic collapse (\mathbf{I}_p).

7.0 RIGID PLASTIC ANALYSIS

As the plastic deformations at collapse are considerably larger than elastic ones, it is assumed that the frame remains rigid between supports and hinge positions i.e. all plastic rotation occurs at the plastic hinges.

Considering a simply supported beam subjected to a point load at midspan, the maximum strain will take place at the centre of the span where a plastic hinge will be formed at yield of full section. The remainder of the beam will remain straight, thus the entire energy will be absorbed by the rotation of the plastic hinge. (See Fig. 12)

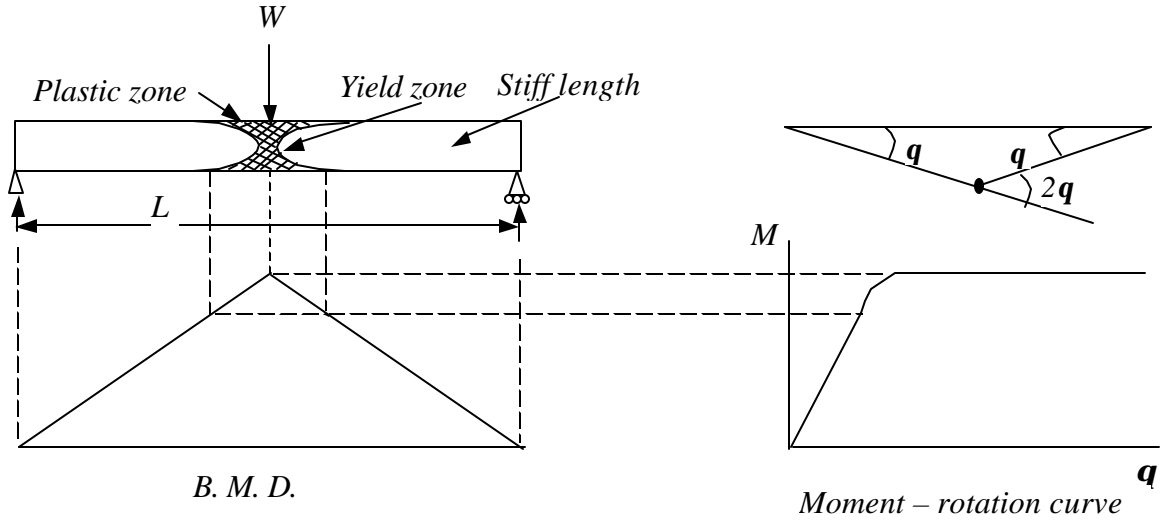

Fig. 12 Simply supported beam at plastic hinge stage

Considering a centrally loaded simply supported beam at the instant of plastic collapse (see Fig. 12)

$$\text{Workdone at the plastic hinge} = M_p 2q \tag{5a}$$

$$\text{Workdone by the displacement of the load} = W \left(\frac{L}{2} \cdot q \right) \tag{5b}$$

At collapse, these two must be equal

$$2M_p \cdot q = W \left(\frac{L}{2} \cdot q \right)$$

$$M_p = \frac{WL}{4} \tag{6}$$

The moment at collapse of an encastre beam with a uniform load is similarly worked out from Fig. 13. It should be noted that three hinges are required to be formed at A, B and C just before collapse.

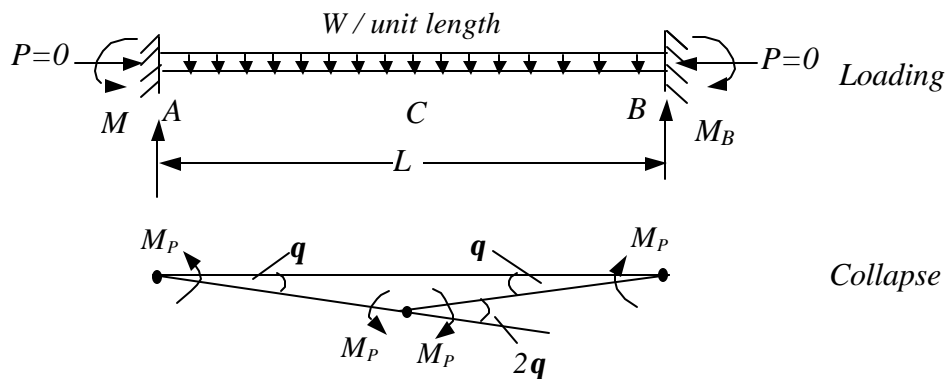

Fig. 13 Encastre Beam

$$\text{Workdone at the three plastic hinges} = M_p (\mathbf{q} + 2\mathbf{q} + \mathbf{q}) = 4M_p \mathbf{q} \tag{7.a}$$

$$\text{Workdone by the displacement of the load} = W/L \cdot L/2 \cdot L/2 \cdot \mathbf{q} \tag{7.b}$$

$$\begin{aligned} \frac{WL}{4} \mathbf{q} &= 4 M_p \mathbf{q} \\ WL &= 16 M_p \end{aligned} \tag{8}$$

$$M_p = \frac{WL}{16} \tag{9}$$

In other words the load causing plastic collapse of a section of known value of M_p is given by eqn. (8). All the three hinges at A , B and C will have a plastic moment of M_p as given in eqn. (9).

7.1 Continuous Beams

Consider next the three span continuous beam of uniform section throughout (constant M_p) as shown in Fig. 14(a). Here a conventional approach is more laborious but the collapse load may be readily determined by consideration of the collapse patterns. Each pattern represents the conversion of each of the three spans into mechanism.

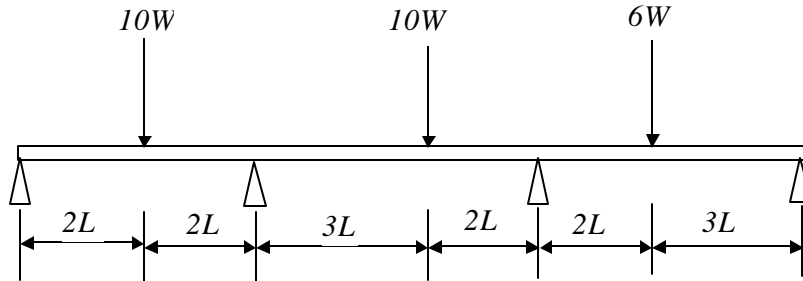

Fig. 14 (a)

Collapse pattern 1:

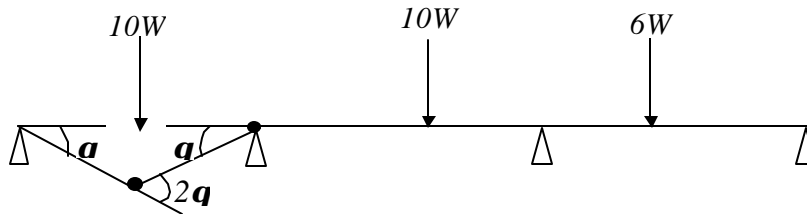

Fig. 14(b)

$$\text{Work done in hinges} = M_p (2\mathbf{q} + \mathbf{q}) = 3 M_p \mathbf{q}$$

$$\text{Work done by loads} = 10 W(2Lq) = 20WLq$$

$$\text{Collapse load, } W_c = 3 M_p / 20L = 0.15 M_p / L$$

Collapse pattern 2:

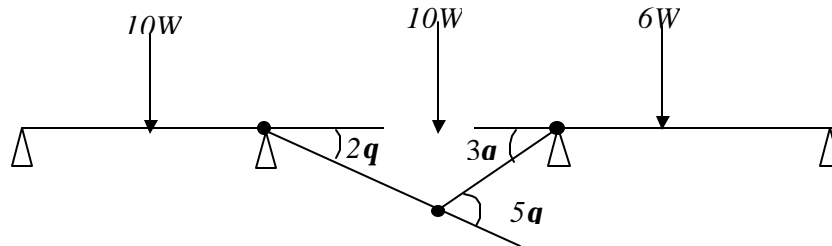

Fig. 14 (c)

$$\text{Work done in plastic hinges} = M_p (2q + 5q + 3q) = 10 M_p q$$

$$\text{Work done by loads} = 10W(6Lq) = 60 WLq$$

$$\text{Collapse load, } W_c = 10 M_p / 60 L = 0.17 M_p / L$$

Collapse pattern 3:

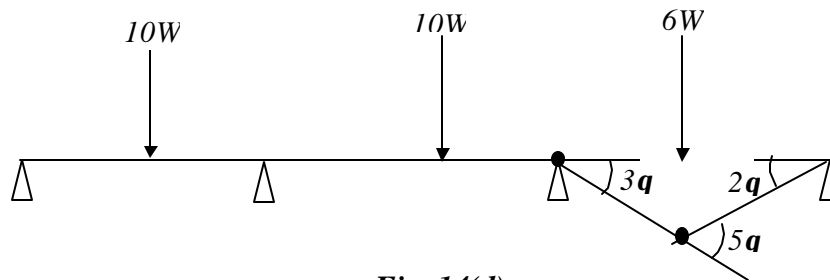

Fig. 14(d)

$$\text{Work done in hinges} = M_p (3q + 5q) = 8 M_p q$$

$$\text{Work done by loads} = 6W(6Lq) = 36 WLq$$

$$\text{Collapse load, } W_c = 8 M_p / 36L = 0.22 M_p / L$$

Thus collapse will occur in the mode of Fig. 14 (b) when $W_c = 0.15 M_p / L$.

7.2 Mechanism Method

In the mechanism or kinematic method of plastic analysis, various plastic failure mechanisms are evaluated. The plastic collapse loads corresponding to various failure mechanisms are obtained by equating the internal work at the plastic hinges to the

external work by loads during the virtual displacement. This requires evaluation of displacements and plastic hinge rotations.

For gabled frames and other such frames, the kinematics of collapse is somewhat complex. It is convenient to use the instantaneous centres of rotation of the rigid elements of the frame to evaluate displacements corresponding to different mechanisms. In this, properties of rotations of a rigid body during an infinitesimally small angle \mathbf{q} are assumed as follows (see Fig.15):

- (i) Any point P will move by distance $r\mathbf{q}$ to point P' normal to the radius vector OP for length r , due to the rotation of the rigid body by an angle \mathbf{q} about O .
- (ii) The work done by a force F due to the rotation of the rigid body about O by an angle \mathbf{q} is given by $F \cdot x \cdot \mathbf{q}$ where x is the shortest (perpendicular distance) between vector F and the centre of rotation O .

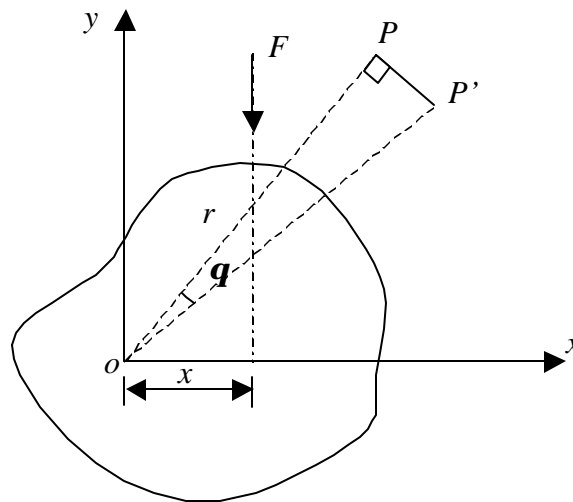

Fig.15 Rigid body rotation

Consider, for example the structure shown in Fig 16. Let us consider the plastic mechanism by formation of plastic hinges A , C , F and G . Let the virtual rotation of the member FG be \mathbf{q} about plastic hinge G . Point F moves, normal to line FG to F' due to rotation about G . This would cause a part of the structure ABC to rotate about point A and point C would move to C' . Since point F moves to F' the instantaneous centre of rotation of segment CDF would be along the line FG . Similarly since point C would move normal to line AC , the instantaneous centre of rotation of element CDF should also be along the line AC . Thus we can locate the instantaneous centre which will be the point of intersection of line AC and GF , obtained by extending them to meet at I .

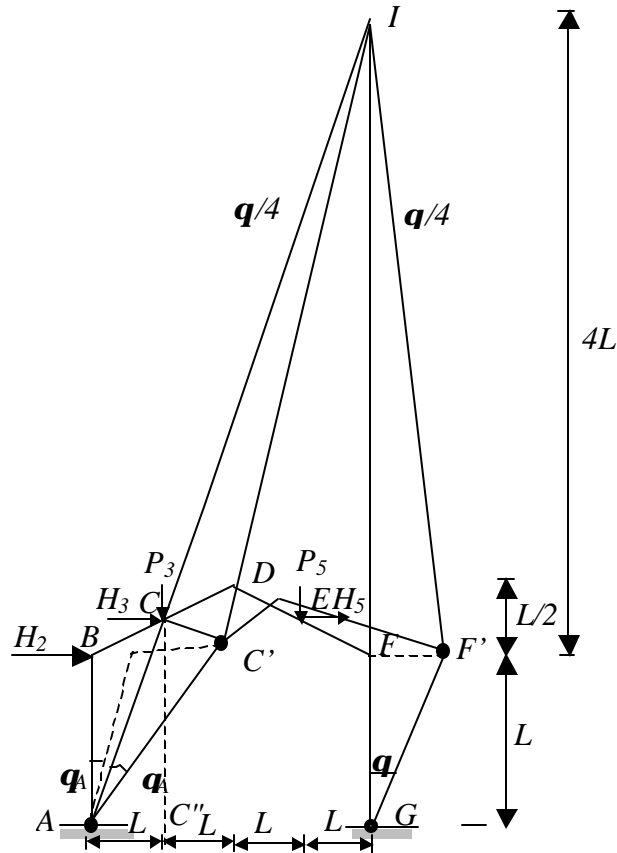

Fig. 16

Let us find the rotation of element CDF about instantaneous centre of rotation I ,

Let $\angle FGF' = \theta$

From FGF' we get $FF' = L \cdot \theta$

To find the location of I , consider similar triangles ACC'' and IAG ,

{EMBED

Equation.3}

{EMBED Equation.3}

Similarly from IFF'

$$(x + L/2)\theta_I = FF' = L \cdot \theta$$

$$(7L/2 + L/2) \theta_I = L\theta$$

$$\theta_I = \frac{\theta}{4}$$

Similarly from ICC' and ACC'

{EMBED
Equation.3}

The displacements of loads in the direction of application of loads are as follows:

Displacement of horizontal loads

$$\text{For } H_2; \mathbf{D}_2 = \begin{Bmatrix} EM \\ BED \end{Bmatrix}$$

$$\text{For } H_3; \mathbf{D}_3 = \begin{Bmatrix} \text{EMBED} \\ \text{Equation.3} \end{Bmatrix}$$

$$\text{For } H_5; \mathbf{D}_5 = \begin{Bmatrix} \text{EMBED} \\ \text{Equation.3} \end{Bmatrix}$$

Displacement of vertical loads

$$\text{For } P_3; \mathbf{D}_2 = \begin{Bmatrix} EM \\ BED \end{Bmatrix}$$

$$\text{For } P_5; \mathbf{D}_5 = \begin{Bmatrix} E \\ MB \end{Bmatrix}$$

The rotations at the plastic hinges are as follows:

$$\mathbf{q}_A = \begin{Bmatrix} E \\ M \end{Bmatrix}$$

$$\mathbf{q}_C = \begin{Bmatrix} \text{EMBED} \\ \text{Equation.3} \end{Bmatrix}$$

$$\mathbf{q}_F = \begin{Bmatrix} \text{EMBED} \\ \text{Equation.3} \end{Bmatrix}$$

$$\mathbf{q}_G = \mathbf{q}$$

With these information the virtual work equation can be written.

7.3 Rectangular Portal Framework and Interaction Diagrams

The same principle is applicable to frames as indicated in Fig. 17(a) where a portal frame with constant plastic moment of resistance M_p throughout is subjected to two independent loads H and V .

This frame may distort in more than one mode. There are basic independent modes for the portal frame, the pure sway of Fig. 17 (b) and a beam collapse as indicated in Fig. 17 (c). There is now however the possibility of the modes combining as shown in Fig. 17(d).

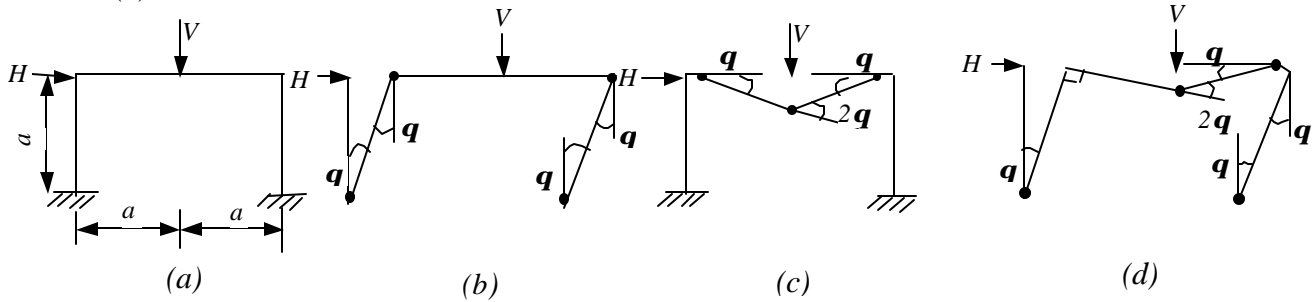

Fig.17 Possible Failure Mechanisms

From Fig. 17(b)

Work done in hinges = $4 M_p q$
 Work done by loads = $Ha q$
 At incipient collapse $Ha / M_p = 4$ (10)

From Fig. 17 (c)

Work done in hinges = $4 M_p q$
 Work done by loads = $Va q$
 At incipient collapse = $Va / M_p = 4$ (11)

From Fig. 17(d)

Work done in hinges = $6 M_p q$
 Work done by loads = $Ha q + Va q$
 At incipient collapse $Ha / M_p + Va / M_p = 6$ (12)

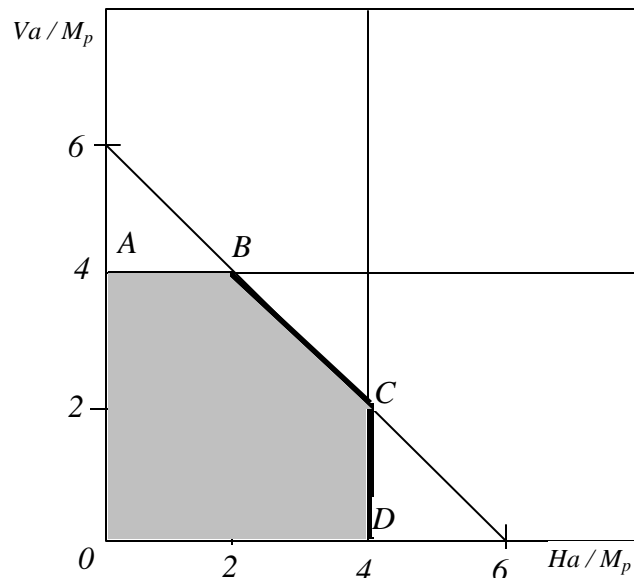

Fig. 18

The resulting equations, which represent the collapse criteria, are plotted on the interaction diagram of Fig. 18. Since any line radiating from the origin represents proportional loading, the first mechanism line intersected represents failure. The failure condition is therefore the line ABCD and any load condition within the area OABCD is therefore safe.

7.4 Frames not of Constant Section Throughout

Let us suppose however that the beam had an enhanced value of fully plastic moment of $2M_p$. The possible modes of collapse are unaltered but wherever a hinge forms at the beam/stanchion joint, it will occur in the weaker member - in this case it will be at the stanchion. For clarity it is customary to draw the hinge location just away from the joint

as indicated in Fig. 19, but in the ensuing geometric computations it is assumed that its location is at the joint. The previous calculation is then modified as follows:

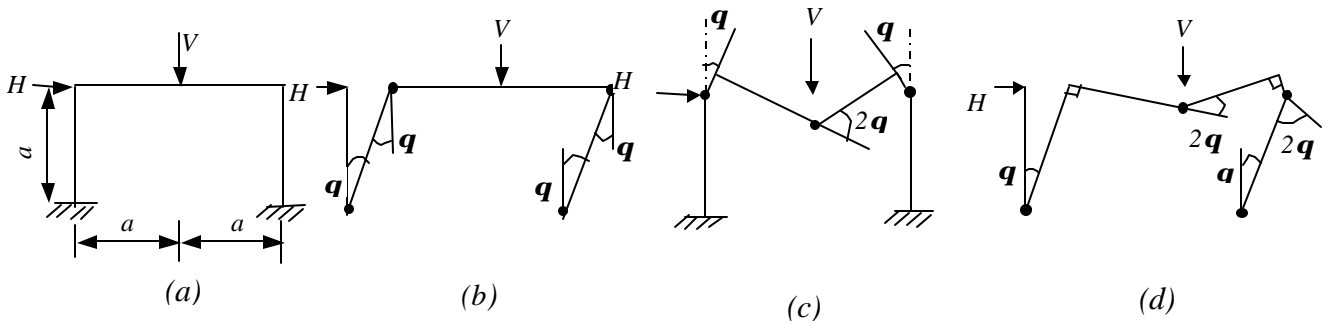

Fig.19

From Fig. 19 (b)

Work done in hinges = $4 M_p q$
 Work done by loads = $Ha q$
 At incipient collapse $Ha / M_p = 4$ (13)

From Fig. 19 (c)

Work done in hinges = $6 M_p q$
 Work done by loads = $Va q$
 At incipient collapse $Va / M_p = 6$ (14)

From Fig.19 (d)

Work done in hinges = $8 M_p q$
 Work done by loads = $Ha q + Va q$
 At incipient collapse $Ha / M_p + Va / M_p = 8$ (15)

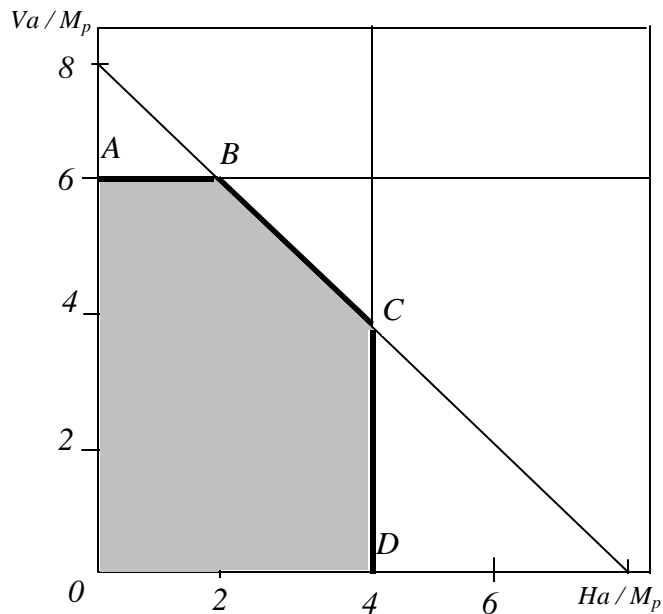

Fig. 20

The interaction diagram then becomes as shown in Fig. 20.

8.0 STABILITY

For plastically designed frames three stability criteria have to be considered for ensuring the safety of the frame. These are

1. General Frame Stability.

2. Local Buckling Criterion.
3. Restraints.

8.1 General Frame Stability

Under loading, all structures move. In some cases this movement is small compared to the frame dimensions and the designer does not need to consider these any further. In other cases, the movement of the structure will be sufficient to cause the factor of safety to drop by a significant amount (for more details readers may wish to refer to *BS:5950 Part 1*, clauses 5.1.3, 5.5.3.2 and 5.5.3.3). In these cases the designer will need to take this drop in the load carrying capacity into account in checking the structure.

8.2 Local Buckling Criterion

At the location of a plastic hinge, there is a considerable strain, and at ultimate load this can reach several times the yield strain. Under these conditions it is essential that the section does not buckle locally, or the moment capacity will drop considerably. In order to ensure that the sections remain stable, limiting values are provided for flange outstands and web depth ratios. In no circumstances should sections not complying with the plastic section classification limits given in the code be used in locations where there are plastic hinges; otherwise there is a real risk of a premature reduction in the moment capacity of the member at the hinge location.

The limits for the sizing of flanges and webs are discussed in another chapter on “Local Buckling and Section Classification”.

8.3 Restraints

In order to ensure that the plastic hinge position does not become a source of premature failure during the rotation, torsional restraint should be provided at the plastic hinge locations. These are discussed in the next chapter, which covers the design requirements in detail.

9.0 EFFECT OF AXIAL LOAD AND SHEAR

If a member is subjected to the combined action of bending moment and axial force, the plastic moment capacity will be reduced.

The presence of an axial load implies that the sum of the tension and compression forces in the section is not zero (Fig. 21). This means that the neutral axis moves away from the equal area axis providing an additional area in tension or compression depending on the type of axial load.

Consider a rectangular member of width b and depth d subjected to an axial compressive force P together with a moment M in the vertical plane (Fig. 21).

The values of M and P are increased at a constant value of M/P until the fully plastic stage is attained, then the values of M and P become:

$$M_{pa} = 0.25 f_y b (d^2 - 4y^2) \tag{16}$$

$$P = 2y \cdot b f_y \tag{17}$$

where $f_y =$ yield stress

$$y = \text{distance from the neutral axis to the stress change for } M_p \text{ without axial force, } M_p = f_y b d^2 / 4 \tag{18}$$

$$\text{If axial force acts alone } -P_y = f_y b d \tag{19}$$

at the fully plastic state.

From equations (16) to (19) the interaction equation can be obtained:

$$M_x/M_p = 1 - P^2/P_y \tag{20}$$

The presence of shear forces will also reduce the moment capacity.

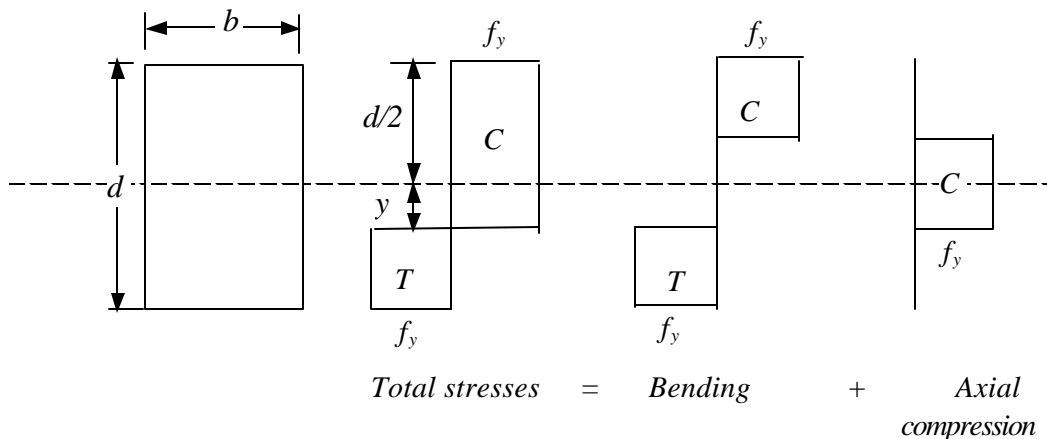

Fig. 21 Effect of axial force on plastic moment capacity

10.0 PLASTIC ANALYSIS FOR MORE THAN ONE CONDITION OF LOADING

When more than one condition of loading can be applied to a beam or structure, it may not always be obvious which is critical. It is necessary then to perform separate calculations, one for each loading condition, the section being determined by the solution requiring the largest plastic moment.

Unlike the elastic method of design in which moments produced by different loading systems can be added together, plastic moments obtained by different loading systems cannot be combined, i.e. the plastic moment calculated for a given set of loads is only

valid for that loading condition. This is because the 'Principle of Superposition' becomes invalid when parts of the structure have yielded.

11.0 CONCLUDING REMARKS

Basic concepts on Plastic Analysis have been discussed in this chapter and the methods of computation of ultimate load causing plastic collapse have been outlined. Theorems of plastic collapse and alternative patterns of hinge formation triggering plastic collapse have been discussed. Worked examples illustrating plastic methods of analysis have been provided.

12.0 REFERENCES

1. Clarke, A. B. and Coverman, S. H. Structural Steelwork, Limit state design, Chapman and Hall Ltd, London, 1987.
2. Horne, M. R. Plastic Theory of Structures, Pergamon Press Ltd, Oxford, 1979.
3. Introduction to Steelwork Design to BS 5950: Part 1, The Steel Construction Institute, 1988
4. Owens G.W., Knowles P.R : "Steel Designers Manual", The Steel Construction Institute, Ascot, England, 1994

Structural Steel Design Project	Job No.	Sheet <i>1</i> of <u>2</u>	Rev.
	Job title: <i>PLASTIC ANALYSIS</i>		
	Worked Example. <i>1</i>		
		Made by <i>RSP</i>	Date <i>April 2000</i>

CALCULATION SHEET	Checked by RN	Date April 2000
-------------------	----------------------	------------------------

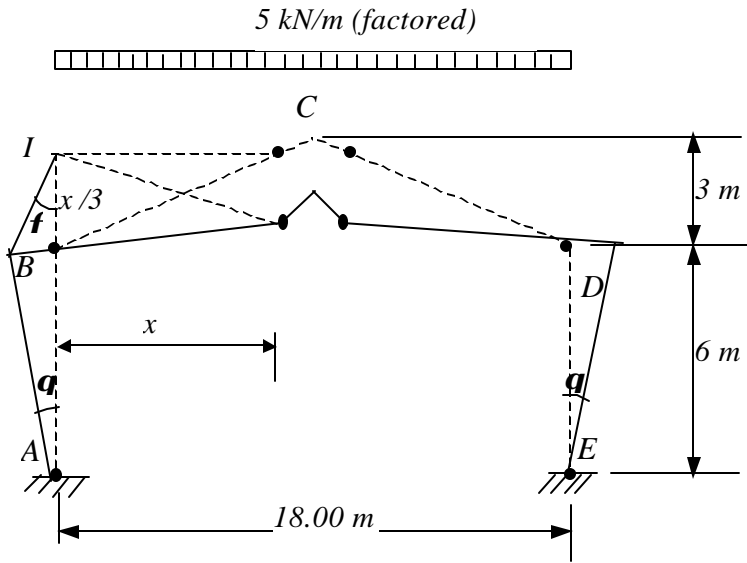

Fig. 22 Portal with fixed base and symmetrical vertical loading

Determine the M_p required for a symmetric single bay pitched portal frame with a factored UDL of 5 kN /m by instantaneous centre method.

In the case of gable frames, computation of the geometrical relationship of the displacement in the direction of the load as the structure moves through the mechanism may become somewhat tedious. In such cases the method of instantaneous centres may be used. This method is discussed below along with its use for solving practical problems.

In the following problem, when the structure moves under loading, the point B will move in a direction perpendicular to line AB . Then its centre of rotation should be along line AB extended. The point C will move vertically downwards and its centre of rotation should lie in a horizontal line. The point I satisfies both the conditions. Thus I is the centre of rotation of the member BC . The rotation at both the column bases is taken as \mathbf{q} Assume that the hinges will form in the rafter at a distance of x from B and very close to roof apex.

Structural Steel Design Project	Job No.	Sheet 2 of 2	Rev.
	Job title: PLASTIC ANALYSIS		
	Worked Example. I		
	Made by	RSP	Date April 2000

CALCULATION SHEET		Checked by RN	Date April 2000										
<p>Data (as shown in Fig. 20).</p> <table> <tr> <td>Frame centres</td> <td>5.0 m</td> </tr> <tr> <td>Span of portal</td> <td>18.0 m</td> </tr> <tr> <td>Eaves height</td> <td>6.0 m</td> </tr> <tr> <td>Eaves to ridge height</td> <td>3.0 m</td> </tr> <tr> <td>Purlin spacing</td> <td>1.5 m</td> </tr> </table>				Frame centres	5.0 m	Span of portal	18.0 m	Eaves height	6.0 m	Eaves to ridge height	3.0 m	Purlin spacing	1.5 m
Frame centres	5.0 m												
Span of portal	18.0 m												
Eaves height	6.0 m												
Eaves to ridge height	3.0 m												
Purlin spacing	1.5 m												
<p>Solution:</p> $(x/3) f = 6q$ $\backslash f = 18 q/x$ $M_p (q + 18 q/x + q + 18 q/x) = 18 q/x [5 x^2 / 2 + (9 - x) 5x]$ $M_p = \frac{9 (-2.5 x^2 + 45 x)}{(18 + x)}$ <p>For maximum value of M_p, $\frac{dM_p}{dx} = 0$</p> $(18 + x)(-5x + 45) - (-2.5 x^2 + 45 x) = 0$ $-2.5 x^2 - 90 x - 810 = 0$ $x = 7.5 \text{ m}$ <p>Substituting in eqn. for M_p,</p> $M_p = \underline{69.5 \text{ kNm}}$													

<p>Structural Steel Design Project</p>	Job No.	Sheet 1 of 6	Rev.
	Job title: PLASTIC ANALYSIS		
	Worked Example. 2		
		Made by RSP	Date April 2000

CALCULATION SHEET	Checked by RN	Date April 2000
--------------------------	----------------------	------------------------

Find M_p for the portal frame with electrically operated travelling crane as shown in Fig. 21 by 'Reactant moment diagram' method. The roof pitch is 30° . Neglect the effect of wind acting vertically on the roof.

Horizontal wind pressure is $= 1 \text{ kN/m}^2$

$g = 1.2$ for the combined effects of wind, crane, dead load and live load.

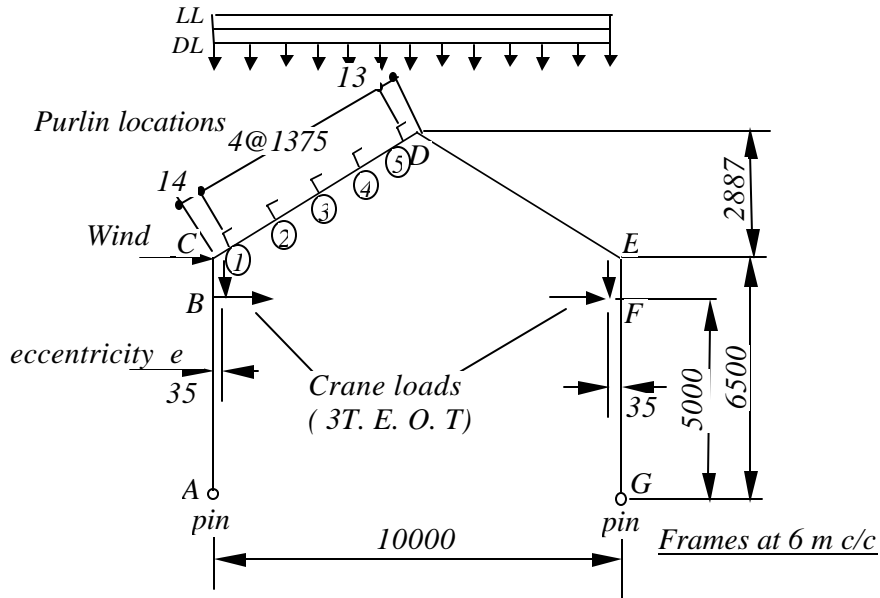

Fig. 23 Summary of typical loads and dimensions for Example 2

PRELIMINARY CALCULATIONS

(1) Forces due to dead load and live load on roof

Superimposed load = 0.6 kN/m^2
 Dead load = 0.5 kN/m^2
 Total load = $(0.6 + 0.5) \cdot 1.2 \cdot 6 = 7.92 \text{ kN/m}$

Structural Steel Design Project	Job No.	Sheet 2 of 6	Rev.
	Job title: PLASTIC ANALYSIS		
	Worked Example. 2		
		Made by RSP	Date April 2000

CALCULATION SHEET	Checked by RN	Date April 2000
--------------------------	----------------------	------------------------

(2) Crane loading

3 ton capacity crane, 9.3 m span.

Horizontal crane loading

This may be shared between each side of the portal, based on the assumption that the crane wheels are flanged, and in effect share the load between the two rails. Check that the crane wheels are flanged when the vendor is selected, or place entire horizontal crane load at point B for a more onerous case.

Vertical crane loading

Maximum wheel load = 26.5 kN (2 wheels)

Minimum wheel load = 7.25 kN (2 wheels)

Maximum reaction at column due to loaded crane = 2 × 26.5 = 53 kN

Minimum reaction at column due to loaded crane = 2 × 7.25 = 14.5 kN

Moment due to vertical crane loading (unfactored)

Moment at B = 53 × 0.35 × 1.2 = 22.3 kNm

Moment at F = 14.5 × 0.35 × 1.2 = 6.1 kNm

Load on the crane bracket is 350 mm eccentric from column centre line.

Transverse crane loading

Transverse load due to crab and load = 0.1 (6.0 + 3.0) = 3.6 kN

Shared between points B and F, i.e. 1.8 kN each.

Moment due to transverse crane loading

Moment at B $\textcircled{5} 1.8 \times \left(\frac{1.2}{113} + \frac{1194}{2} \right) \frac{10.82}{1000} \text{kNm}$

Split the frame at the apex, then it can be treated as two cantilevers.

Total roof load = 7.92 kN/m

Load at purlin point = 5.61 kN

	Job No.	Sheet 3 of 6	Rev.
--	---------	--------------	------

Structural Steel Design Project	Job No.	Sheet 3 of 6	Rev.
	Worked Example PLASTIC ANALYSIS		
		Made by RSP	Date April 2000
		Checked by RN	Date April 2000
<p>③ CALCULATION SHEET</p> <p>Load $\left(\frac{1191}{2} + \frac{1191}{2} \right) \frac{7.92}{1000} = 9.43 \text{ kN}$</p> <p>Moment at purlin point $\textcircled{3} = \left[9.43 \times 1191 + 5.61 \times (1191 \times 2) \right] \frac{1}{1000}$</p> <p style="padding-left: 100px;">$= 24.59 \text{ kNm}$</p> <p><u>Moment at A</u></p> <p>Moment due to roof load $= 7.92 \times 5 \times 2.5 = 99 \text{ kNm}$</p> <p>Moment due to wind load on ABC $= (1 \times 6 \times 6.5) \frac{6.5}{2} \times 1.2 = 152.1 \text{ kNm}$</p> <p>Moment due to vertical crane loading $= 53 \times 0.35 \times 1.2 = 22.3 \text{ kNm}$</p> <p>Moment due to transverse crane load $= 1.8 \times 1.2 \times 5 = 10.8 \text{ kNm}$</p> <p style="padding-left: 100px;"><i>Total</i> $= 284.2 \text{ kNm}$</p> <p><u>Moment at G</u></p> <p>Moment due to roof load $= 99 \text{ kNm}$</p> <p>Moment due to vertical crane loading $= 6.1 \text{ kNm}$</p> <p>Moment due to transverse crane load $= 10.8 \text{ kNm}$</p> <p style="padding-left: 40px;"><i>Total</i> $= 115.9 \text{ kNm}$</p> <p><i>Summary of the reactant moment diagram method for the portal frame is shown in Fig. 22(a) and 22(b). For solution by calculation, let purlins be numbered 1 to 'n' from roof to apex. Put moment for each purlin point into the reactant moment diagram equations and solve for successive purlin points. The largest value of M_p found by this method is the design case.</i></p>			

Structural Steel Design Project	Job No.	Sheet 4 of 6	Rev.
	Job title: PLASTIC ANALYSIS		
	Worked Example. 2		
	CALCULATION SHEET	Made by RSP	Date April 2000
Checked by RN		Date April 2000	
<p><i>For this design the equations for M_p are:</i></p> <p>At A : $284.2 - m - 9.387 R - 5 S = 0$</p> <p>At point ③ : $24.59 - m - 1.42 R - 2.495 S = -M_p$</p> <p>At E : $99 - m - 2.887 R + 5 S = +M_p$</p> <p>At G : $115.9 - m - 9.387 R + 5 S = 0$</p> <p><i>Using the method and equations illustrated in Fig. 22(b) these equations can be solved simultaneously (or by matrix) to give $R = 16.2$ kN, $S = 16.83$ kN, $m = 48$ kN, and $M_p = 88.4$ kNm.</i></p>			

Structural Steel Design Project CALCULATION SHEET	Job No.	Sheet 5 of 6	Rev.
	Job title: PLASTIC ANALYSIS		
	Worked Example. 2		
	Made by RSP	Date April 2000	
	Checked by RN	Date April 2000	

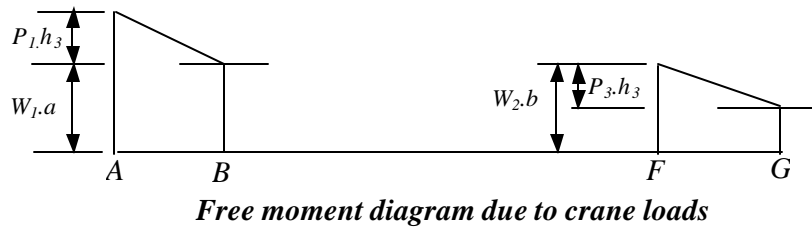
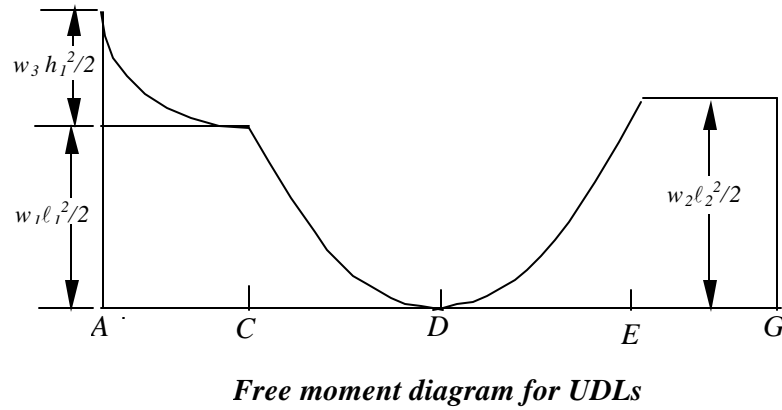
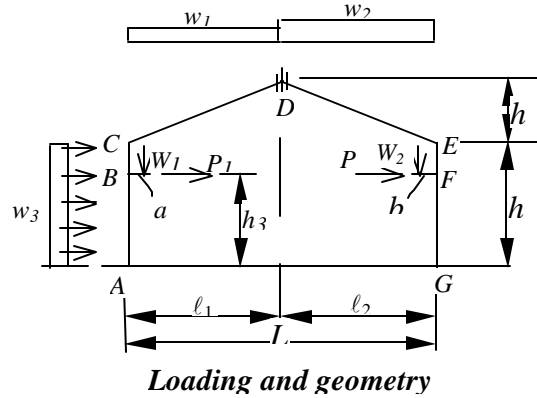
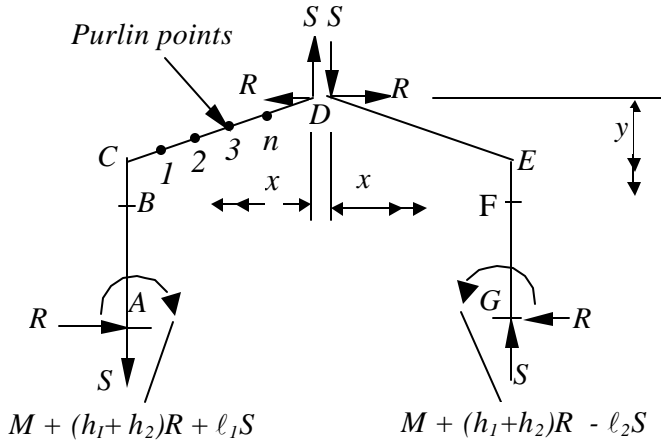

Fig. 24(a) Loadings and free moment diagrams for the portal frame

Structural Steel Design Project	Job No.	Sheet 6 of 6	Rev.
	Job title: PLASTIC ANALYSIS		
	Worked Example. 2		
	Made by RSP		Date April 2000
CALCULATION SHEET	Checked by RN		Date April 2000

For the purpose of analysis, frame is notionally split at apex, and treated as two cantilevers



Equations for fixed bases

at C ; Free $M - M - h_2R - \ell_1S = +M_p$
 at n ; Free $M - M - yR - xS = -M_p$
 at E ; Free $M - M - h_2R + \ell_2S = +M_p$
 at G ; Free $M - M - (h_1+h_2)R + \ell_2S = -M_p$

Equations for pinned bases are as for fixed bases but with moment at the bases set to zero. Put the factored values of free moment into the equations and solve simultaneously or by matrix. Solve for successive purlin points, thus finding the largest value of M_p

Redundant reactants

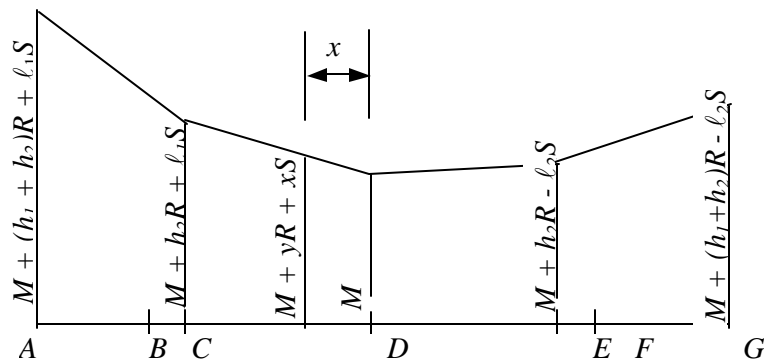

Redundant reactant moment diagram

Fig. 24(b) Summary of the reactant moment diagram method for a portal frame