

BOLTED CONNECTIONS – I

1.0 INTRODUCTION

Connections form an important part of any structure and are designed more conservatively than members. This is because, connections are more complex than members to analyse, and the discrepancy between analysis and actual behaviour is large. Further, in case of overloading, we prefer the failure confined to an individual member rather than in connections, which could affect many members.

Connections account for more than half the cost of structural steelwork and so their design and detailing are of primary importance for the economy of the structure.

The type of connection designed has an influence on member design and so must be decided even prior to the design of the structural system and design of members. For example, in the design of bolted tension members, the net area is calculated assuming a suitable number and diameter of bolts based on experience. Therefore, it is necessary to verify the net area after designing the connection. Similarly in the analysis of frames, the member forces are determined by assuming the connections to be pinned, rigid, or semi-rigid, as the actual behaviour cannot be precisely defined.

Just as members are classified as bending members or axially loaded members depending on the dominant force/moment resisted, connections are also classified into idealised types while designing. But the actual behaviour of the connection may be different and this point should always be kept in mind so that the connection designed does not differ significantly from the intended type. Take for example, the connection of an axially loaded truss member at a joint. If the truss is assumed to be pin jointed, then the member should ideally be connected by means of a single pin or bolt. However, in practice, if the pin or bolt diameter works out to be larger than that possible, more than one bolt will be used. The truss can then be considered pin-jointed only if the bending due to self-weight or other superimposed loads is negligible. Note that the connection behaviour will also influence the calculation of the effective length for the buckling analysis of struts.

The connections provided in steel structures can be classified as 1) riveted 2) bolted and 3) welded connections. Riveted connections were once very popular and are still used in some cases but will gradually be replaced by bolted connections. This is due to the low strength of rivets, higher installation costs and the inherent inefficiency of the connection. Welded connections have the advantage that no holes need to be drilled in the member and consequently have higher efficiencies. However, welding in the field may be difficult, costly, and time consuming. Welded connections are also susceptible to failure by cracking under repeated cyclic loads due to fatigue which may be due to working loads such as trains passing over a bridge (high-cycle fatigue) or earthquakes (low-cycle fatigue). A special type of bolted connection using High Strength Friction Grip (HSFG)

© Copyright reserved

bolts has been found to perform better under such conditions than the conventional black bolts used to resist predominantly static loading. Bolted connections are also easy to inspect and replace. The choice of using a particular type of connection is entirely that of the designer and he should take his decision based on a good understanding of the connection behaviour, economy and speed of construction.

In this chapter, the different types of bolts and bolted connections used in steel structures are introduced. The scope of the present chapter is limited to bolted connections used in tension and compression members as well as in hangers. Bolted connections, which resist moments and connections between structural members, will be covered in the next chapter.

2.0 BOLTED CONNECTIONS

Connections can also be classified in the following ways:

(a) *Classification based on the type of resultant force transferred:* The bolted connections are referred to as concentric connections (force transfer in tension and compression member), eccentric connections (in reaction transferring brackets) or moment resisting connections (in beam to column connections in frames).

Ideal concentric connections should have only one bolt passing through all the members meeting at a joint [Fig. 1(a)]. However, in practice, this is not usually possible and so it is only ensured that the centroidal axes of the members meet at one point [See Fig. 1(b)].

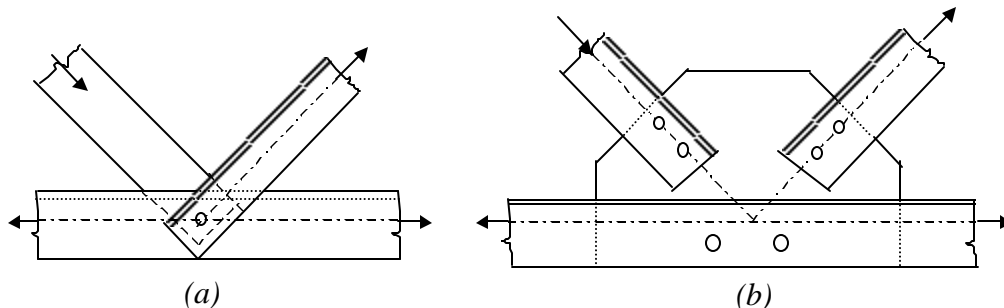

Fig. 1 Concentric Connections

The Moment connections are more complex to analyse compared to the above two types and are shown in Fig. 2(a) and Fig. 2(b). The connection in Fig. 2(a) is also known as bracket connection and the resistance is only through shear in the bolts.

The connection shown in Fig. 2(b) is often found in moment resisting frames where the beam moment is transferred to the column. The connection is also used at the base of the column where a base plate is connected to the foundation by means of anchor bolts. In this connection, the bolts are subjected to a combination of shear and axial tension. Moment resisting connections will be dealt with in the next chapter.

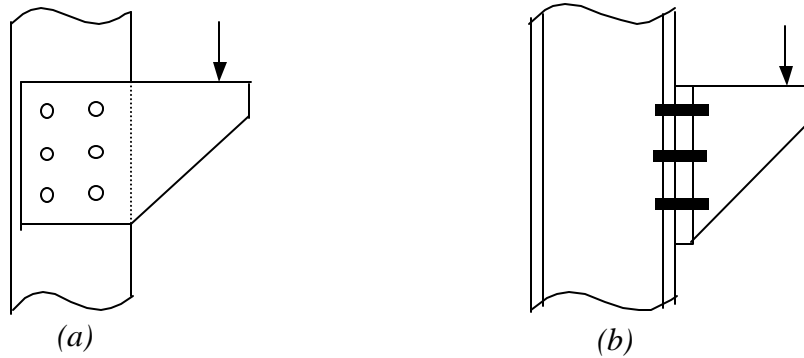

Fig. 2 Moment Connections

(b) *Classification based on the type of force experienced by the bolts:* The bolted connections can also be classified based on geometry and loading conditions into three types namely, shear connections, tension connections and combined shear and tension connections.

Typical shear connections occur as a *lap* or a *butt* joint used in the tension members [See Fig. 3]. While the lap joint has a tendency to bend so that the forces tend to become collinear, the butt joint requires *cover plates*. Since the load acts in the plane of the plates, the load transmission at the joint will ultimately be through shearing forces in the bolts.

In the case of lap joint or a single cover plate butt joint, there is only one shearing plane, and so the bolts are said to be in *single shear*. In the case of double cover butt joint, there are two shearing planes and so the bolts will be in *double shear*. It should be noted that the single cover type butt joint is nothing but lap joints in series and also bends so that the centre of the cover plate becomes collinear with the forces.

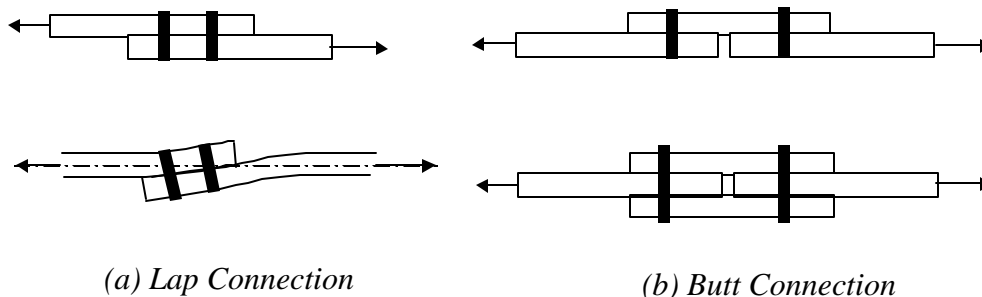

Fig. 3 Shear Connections

A hanger connection is shown in Fig. 4(a). In this connection, load transmission is by pure tension in the bolts. In the connection shown in Fig. 4(b), the bolts are subjected to both tension and shear.

(c) *Classification based on force transfer mechanism by bolts:* The bolted connections are classified as bearing type (bolts bear against the holes to transfer the force) or friction type (force transfer between the plates due to the clamping force generated by the pre-tensioning of the bolts). The force transfer in either case is discussed in more detail later.

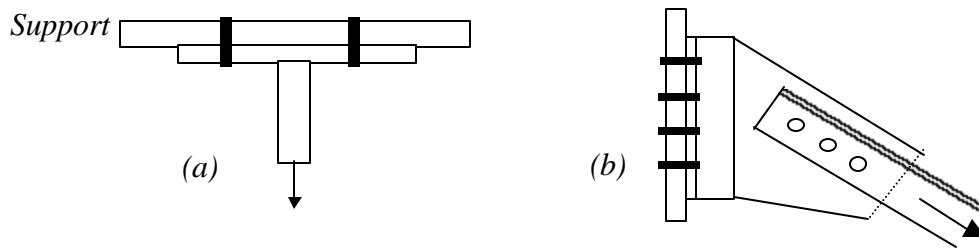

Fig. 4 (a) Tension Connection (b) Tension plus Shear Connection

3.0 BOLTS AND BOLTING

Bolts used in steel structures are of three types: 1) Black Bolts, 2) Turned and Fitted Bolts and 3) High Strength Friction Grip (HSFG) Bolts.

The International Standards Organisation designation for bolts, also followed in India, is given by Grade $x.y$. In this nomenclature, x indicates one-tenth of the minimum ultimate tensile strength of the bolt in kgf/mm^2 and the second number, y , indicates one-tenth of the ratio of the yield stress to ultimate stress, expressed as a percentage. Thus, for example, grade 4.6 bolt will have a minimum ultimate strength 40 kgf/mm^2 (392 Mpa) and minimum yield strength of 0.6 times 40, which is 24 kgf/mm^2 (235 Mpa).

Black bolts are unfinished and are made of mild steel and are usually of Grade 4.6. Black bolts have adequate strength and ductility when used properly; but while tightening the nut snug tight (“Snug tight” is defined as the tightness that exists when all plies in a joint are in firm contact) will twist off easily if tightened too much. Turned –and- fitted bolts have uniform shanks and are inserted in close tolerance drilled holes and made snug tight by box spanners. The diameter of the hole is about 1.5 to 2.0 mm larger than the bolt diameter for ease in fitting. High strength black bolts (grade 8.8) may also be used in connections in which the bolts are tightened snug fit.

In these *bearing type of connections*, the plates are in firm contact but may slip under loading until the hole surface bears against the bolt. The load transmitted from plate to bolt is therefore by bearing and the bolt is in shear. Under dynamic loads, the nuts are liable to become loose and so these bolts are not allowed for use under such loading. In situations where small slips can cause significant effects as in beam splices, black bolts are not preferred. However, due to the lower cost of the bolt and its installation, black bolts are quite popular in simple structures subjected to static loading.

Turned and fitted bolts are available from grade 4.6 to grade 8.8. For the higher grades there is no definite yield point and so 0.2% proof stress is used.

High Strength Friction Grip bolts (HSFG) provide extremely efficient connections and perform well under fluctuating/fatigue load conditions. These bolts should be tightened to their proof loads and require hardened washers to distribute the load under the bolt heads.

The washers are usually tapered when used on rolled steel sections. The tension in the bolt ensures that no slip takes place under working conditions and so the load transmission from plate to the bolt is through friction and not by bearing. However, under ultimate load, the friction may be overcome leading to a slip and so bearing will govern the design.

HSFG bolts are made from quenched and tempered alloy steels with grades from 8.8 to 10.9. The most common are, the so-called, general grade of 8.8 and have medium carbon content, which makes them less ductile. The 10.9 grade have a much higher tensile strength, but lower ductility and the margin between the 0.2% yield strength and the ultimate strength is also lower.

The tightening of HSFG bolts can be done by either of the following methods:

1. *Turn-of-nut tightening method*: In this method the bolts are first made snug tight and then turned by specific amounts (usually either half or three-fourth turns) to induce tension equal to the proof load.
2. *Calibrated wrench tightening method*: In this method the bolts are tightened by a wrench calibrated to produce the required tension.
3. *Alternate design bolt installation*: In this method special bolts are used which indicate the bolt tension. Presently such bolts are not available in India.
4. *Direct tension indicator method*: In this method special washers with protrusions are used [Fig. 5(b)]. As the bolt is tightened, these protrusions are compressed and the gap produced by them gets reduced in proportion to the load. This gap is measured by means of a feeler gauge, consisting of small bits of steel plates of varying thickness, which can be inserted into the gap.

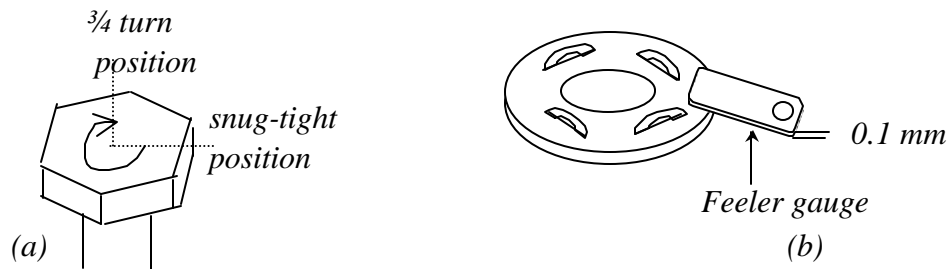

Fig. 5 Tightening of HSFG bolts

Since HSFG bolts under working loads, do not rely on resistance from bearing, holes larger than usual can be provided to ease erection and take care of lack-of-fit. Typical hole types that can be used are standard, extra large and short or long slotted. These are shown in Fig. 6. However the type of hole will govern the strength of the connection.

Holes must also satisfy pitch and edge/end distance criteria. A minimum pitch is usually specified for accommodating the spanner and to limit adverse interaction between the bearing stresses on neighbouring bolts. Maximum pitch criteria takes care of buckling of the plies under compressive loads.

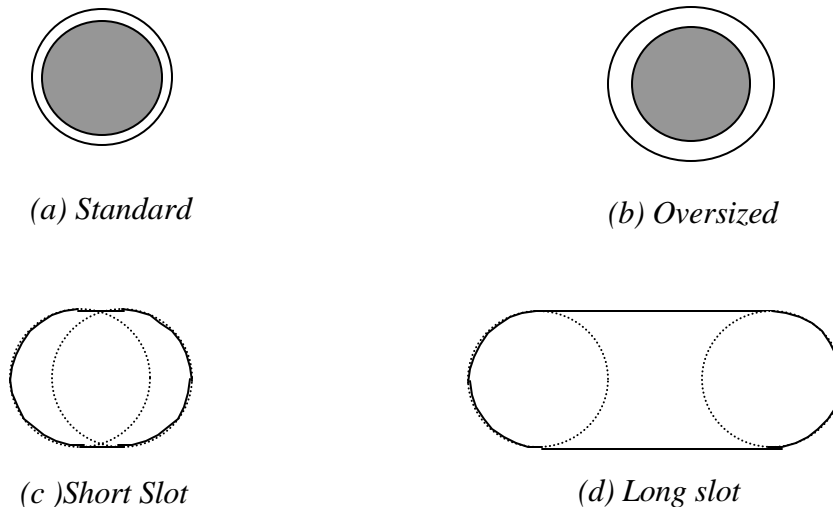

Fig. 6 Hole types for HSFG bolts

4.0 FORCE TRANSFER MECHANISM

In this section the force transfer mechanisms of bearing and friction type of bolted connections are described. This would help in identifying the modes of failure discussed in the next section.

4.1 Force transfer by shear in bolts

Fig. 7(a) shows the free body diagram of the shear force transfer in bearing type of bolted connection. It is seen that tension in one plate is equilibrated by the bearing stress between the bolt and the hole in the plate. Since there is a clearance between the bolt and the hole in which it is fitted, the bearing stress is mobilised only after the plates slip relative to one another and start bearing on the bolt. The section $x-x$ in the bolt is critical section for shear. Since it is a lap joint there is only one critical section in shear (single shear) in the bolt. In the case of butt splices there would be two critical sections in the bolt in shear (double shear), corresponding to the two cover plates.

The free body diagram of an HSFG connection is shown in Fig. 7(b). It can be seen that the pretension in the bolt causes clamping forces between the plates even before the external load is applied. When the external load is applied, the tendency of two plates to slip against one another is resisted by the friction between the plates. The frictional resistance is equal to the coefficient of friction multiplied by the normal clamping force between the plates. Until the externally applied force exceeds this frictional resistance the relative slip between the plates is prevented. The HSFG connections are designed such that under service load the force does not exceed the frictional resistance so that the relative slip is avoided during service. When the external force exceeds the frictional resistance the plates slip until the bolts come into contact with the plate and start bearing against the hole. Beyond this point the external force is resisted by the combined action of the frictional resistance and the bearing resistance.

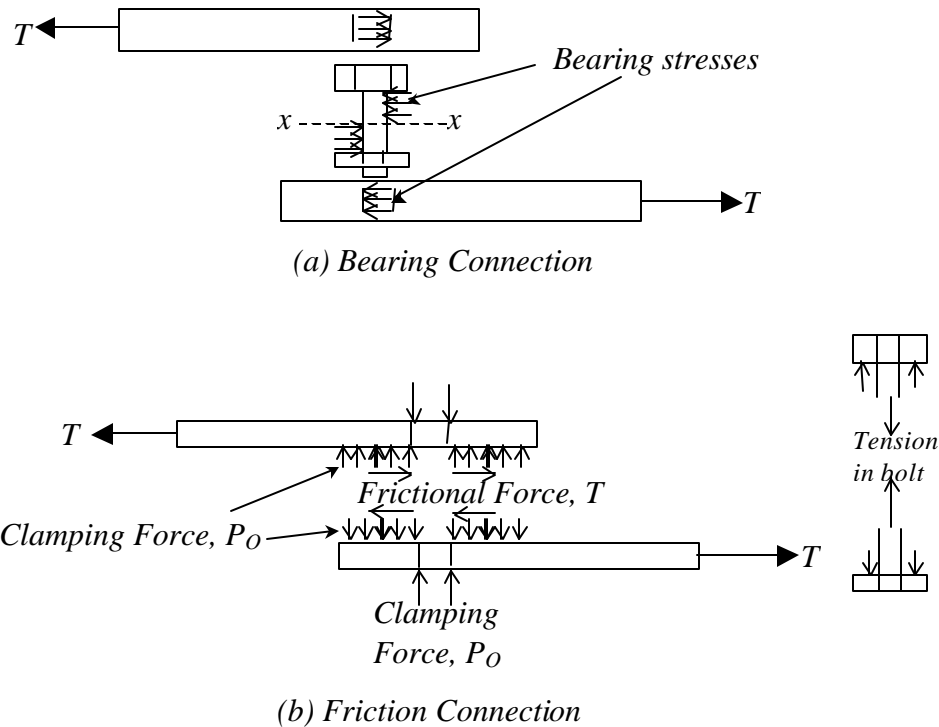

Fig. 7 Bolt Shear Transfer – Free Body Diagram

4.2 Transfer of tension by bolts

The free body diagram of the tension transfer in a bearing type of bolted connection is shown in Fig. 8(a). The variation of bolt tension due to externally applied tension is shown in Fig. 8(c). It is seen that before any external tension is applied, the force in the bolt is almost zero, since the bolts are only snug tight. As the external tension is increased it is equilibrated by the increase in bolt tension. Failure is reached due to large elongation when the root of the bolt starts yielding. Depending on the relative flexibility of the plate and the bolt, sometimes the opening of the joint may be accompanied by prying action [Fig. 8(d)].

The free body diagram of an HSFG bolted connection is shown in Fig. 8(b). It is seen that even before any external load is applied, the force in the bolt is equal to proof load. Correspondingly there is a clamping force between the plates in contact. When the external load is applied, part of the load (nearly 10%) of the load is equilibrated by the increase in the bolt force. The balance of the force is equilibrated by the reduction in contact between the plates. This process continues and the contact between the plates is maintained until the contact force due to pre-tensioning is reduced to zero by the externally applied load. Normally, the design is done such that the externally applied tension does not exceed this level. After the external force exceeds this level, the behaviour of the bolt under tension is essentially the same as that in a bearing type of joint.

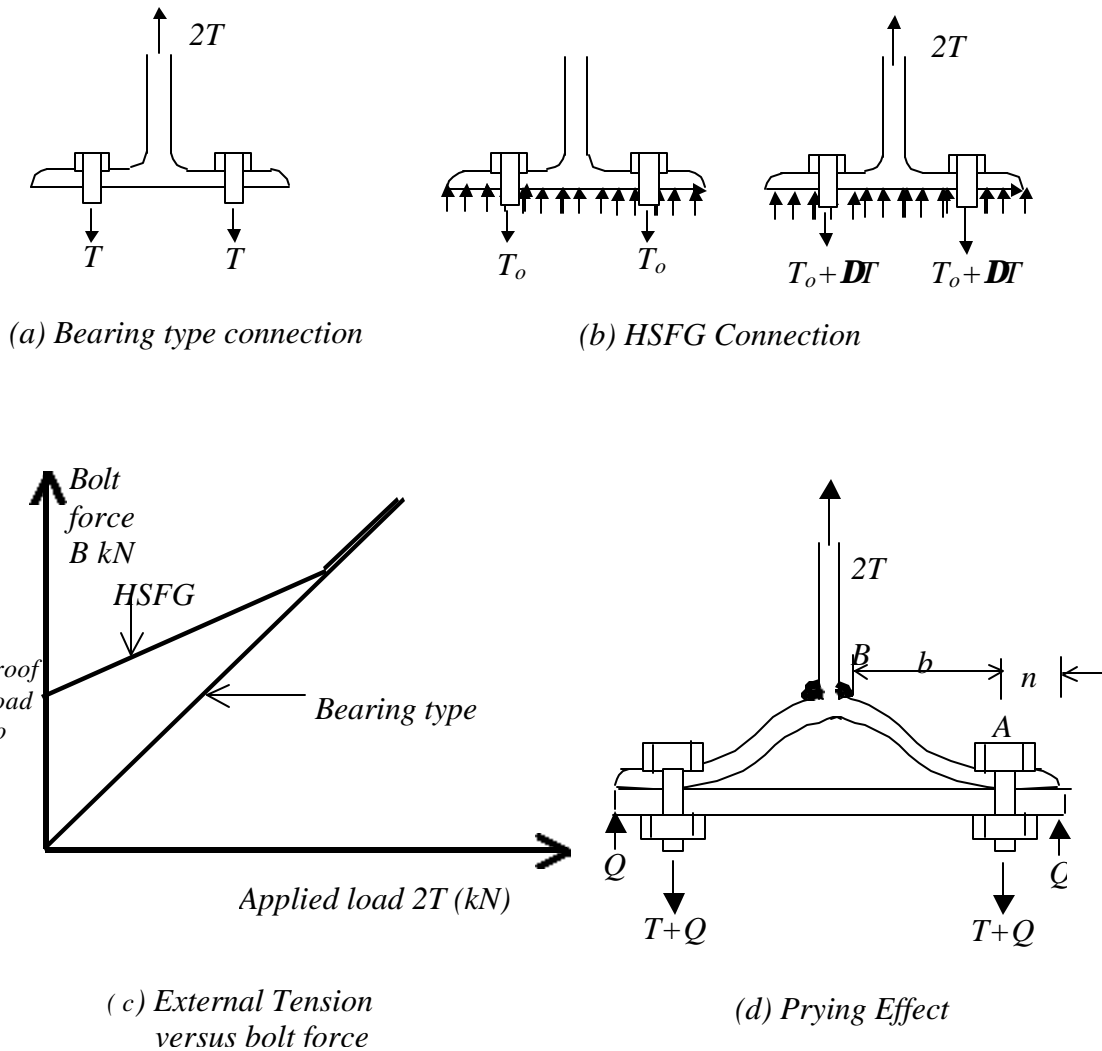

Fig. 8 Bolts under tension and prying effect

The design formula for minimum prying force is given by (Owens and Cheal, 1989)

{ EMBED Equation.3 } (1)

where, b is the distance from the bolt centreline to the toe of the fillet weld or to half the root radius for a rolled section (see Fig. 8d); n = distance between prying force and bolt centreline and is the minimum of, either the end distance, or the value given by eq.(2); $\mathbf{b} = 2$ for non pre-loaded bolt; $\mathbf{g} = 1.5$ for limit state design; w = the effective width of flange per pair of bolts; p_o = the proof stress in consistent units and t is the thickness of the end plate.

{ EMBED Equation.3 } (2)

Even if the bolts are strong enough to carry the additional prying forces, the plate can fail by developing a mechanism with yield lines at the centreline of the bolt and at the distance b from it. Therefore, the minimum thickness of the end plate (t), to avoid yielding of the plate, can be obtained by equating the moment in the plate at the bolt centreline (point A) and at the distance b from it (point B), to the plastic moment capacity of the plate M_p . Thus,

$$\{ \text{EMBED Equation.3} \} \quad (3)$$

$$\{ \text{EMBED Equation.3} \} \quad (4)$$

taking M_p as

$$\{ \text{EMBED Equation.3} \} \quad (5)$$

the minimum thickness for the end plate can be obtained as

$$\{ \text{EMBED Equation.3} \} \quad (6)$$

The corresponding prying force can then be obtained as $Q = M_p/n$. If the total force in the bolt ($T+Q$) exceeds the tensile capacity of the bolt, then the thickness of the end plate will have to be increased.

5.0 FAILURE OF CONNECTIONS

5.1 Connections in shear

The failure of connections with bearing bolts in shear involves either bolt failure or the failure of the connected plates. In the case of HSFG bolts, however, it may simply be a slip between the connected plates. In this section, the failure modes are described along with the codal provisions for design and detailing shear connections.

5.1.1 Bearing bolts

In connections made with bearing type of bolts, the behaviour is linear until i) yielding takes place at the net section of the plate under combined tension and flexure or ii) shearing takes place at the bolt shear plane or iii) failure of bolt takes place in bearing, iv) failure of plate takes place in bearing and v) block shear failure occurs. Of these the first is discussed in the chapter on tension members while the last is described separately in section 5.4. The remaining three is described below.

1. Shearing of bolts: The shearing of bolts can take place in the threaded portion of the bolt and so the area at the root of the threads, also called the tensile stress area A_t , is taken as the shear area A_s . The shear area is specified in the code and is usually about 0.8 times the shank area. However, if it is ensured that the threads will not lie in the shear plane then the full area can be taken as the shear area. The shear strength per bolt is given by

{ EMBED Equation.3 }
(7)

where p_s is the ultimate shear stress in the bolt given in Table 1.

2. *Bearing failure of bolt:* If the connected plates are made of high strength steel then failure of bolt can take place by bearing. The bearing strength per bolt is given by

{ EMBED Equation.3 }
(8)

where, p_{bb} is the permissible bearing stress, d is the nominal diameter of the bolt and t is the combined thickness of the thinner plates bearing on the bolt in any direction. This governs the design when grade 4.6 bolts are used in plates of grade 43 and 50 steels.

3. *Bearing failure of plates:* If the plate material is weaker than the bolt material, then failure will occur by bearing of the bolt on the plate. The bearing area is given by the nominal diameter of the bolt times the combined thickness of the plates bearing in any direction. The bearing strength of plate is given by

$$P_{bs} = p_{bs} d t \quad \text{---} \quad (9)$$

where, p_{bs} is the permissible bearing stress for the plate (given in Table 2 for some standard grades of steel) and e is the end distance. Note that this governs the design in the case of grade 4.6 bolts in ST-42-S steel and HSFG bolts in all grades of steel.

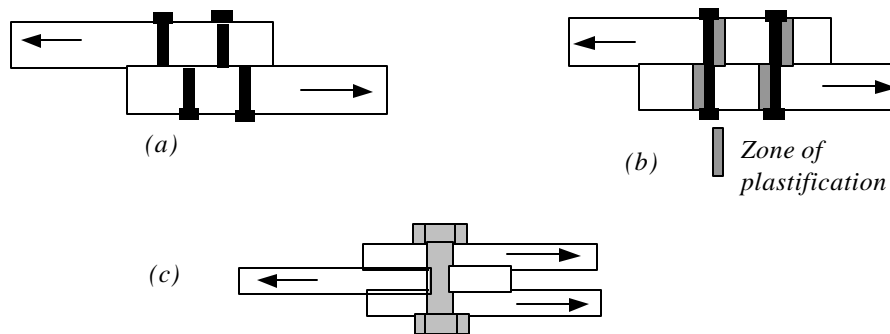

Fig. 9 Types of failures in a shear connection (a) Shearing of bolts (b) Bearing failure of plate (c) Bearing failure of bolt

In addition to the above, the plate may also tear or burst at the edge due to inadequate edge distance. Therefore, to develop the full bearing stress, the bolt has to have adequate distance from the edge of the plate. The minimum edge distance specified in BS 5950 is $1.4D$ where D is the diameter of the bolt hole. For end distances e less than $2d$, the bearing value is proportionally reduced.

Table .1 Bolt strengths in clearance holes in MPa

Bolt strengths	Bolt grade	
	4.6	8.8
Shear strength p_s	160	375
Bearing strength p_{bb}	435	970
Tension strength p_t	195	450

Table 2 Bearing strengths of connected parts in MPa

Steel grade	ST42S	Gr.43	Gr.50
Bearing bolts p_{bs}	418	460	550
HSFG bolts p_{bg}	650	825	1065

The underlying assumption behind the design of bolted connections, namely that all bolts carry equal load is not true in some cases as mentioned below.

In long joints, the bolts farther away from the centre of the joint will carry more load than the bolts located close to the centre. Therefore, for joints having more than two bolts on either side with the distance between the first and the last bolt exceeding 500 mm, the shear capacity of the bolts is reduced as follows:

$$\{ \text{EMBED Equation.3} \} \quad (10)$$

where L_j = length of the joint. Similarly, if the grip length exceeds five times the nominal diameter, the strength is reduced as specified in BS 5950. In multibolt connections, due to hole mismatch, all the bolts may not carry the same load. However, under ultimate load, due to high bearing ductility of the plates considerable redistribution of the load is possible and so the assumption that all bolts carry equal load may be considered valid.

5.1.2 HSFG bolts

HSFG bolts will come into bearing only after slip takes place. Therefore if slip is critical (i.e. if slip cannot be allowed) then one has to calculate the slip resistance, which will govern the design. However, if slip is not critical, and limit state method is used then bearing failure can occur at the Limit State of collapse and needs to be checked. Even in the Limit State method, since HSFG bolts are designed to withstand working loads without slipping, the slip resistance needs to be checked anyway as a Serviceability Limit State.

1. *Slip Resistance:* Slip Resistance of parallel shank HSFG bolts is given by an expression similar to the frictional force between surfaces in contact.

$$\text{Slip resistance per bolt } P_{sl} = 1.1 K_s \mathbf{m} P_o \quad (11)$$

where K_s is a factor which takes care of the frictional area in different hole types ($K_s = 1.0$ for clearance holes, $K_s = 0.85$ for oversized holes and long slots perpendicular to the load and $K_s = 0.6$ for long slots parallel to the load); \mathbf{m} is the slip factor = 0.45 for untreated (non-galvanised, non-painted) surfaces and P_o is the proof load (see Table 3).

2. *Bearing strength:* The bearing strength of plates for parallel shank friction grip fasteners is given by

$$P_{bg} = p_{bg} d t \quad \text{--- (12)}$$

where e is the end distance and p_{bg} is the bearing stress given in Table 2.

Table 3 Design Capacities of HSFG bolts

Nominal dia. f (mm)	16	20	22	24	27	30	36
Proof Load P_o (kN)	92.1	144.0	177.0	207.0	234.0	286.0	418.0
Ten.cap. $P_t = 0.9P_o$ kN	82.9	129.6	159.3	186.3	210.6	257.4	376.2
Slip cap P_{sl} kN	45.6	71.3	87.6	102.5	115.8	141.6	206.9
Note: Proof stress $p_o = 576$ MPa for $f \leq 24$ and $= 510$ MPa for $f > 24$							

5.2 Tension Failure

In a tension or hanger connection, the applied load produces tension in the bolts. If the attached plate is allowed to deform, additional tensile forces called prying forces are developed in the bolts as shown in Fig. 8. The prying forces can be kept small by using a thick plate or by limiting the distance between the bolt and the plate edge. Black bolts and turned and fitted bolts have sufficient ductility which takes care of prying forces simply by an increase in the bolt strain under constant yield stress. Tensile stresses recommended by BS 5950 for grade 4.6 and grade 8.8 bolts are 195 and 450 N/mm² respectively. However, HSFG bolts which are pre-tensioned and which have less ductility are susceptible to failure and so are normally designed to take only 0.9 times their proof load.

5.3 Combined Shear and tension failure

In the case of black bolts subjected to combined action of shear and tension the following relation has to be satisfied.

$$\{ \text{EMBED Equation.3} \} \quad \text{--- (13)}$$

where, F_s = applied shear, F_t = applied tension, P_s = shear capacity and P_t = tension capacity. This gives a trilinear interaction curve as shown in Fig. 10.

For HSFG bolts subjected to combined action of shear and tension, the following relation has to be satisfied.

$$\frac{F_s}{P_{sl}} + 0.8 \frac{F_t}{P_t} \leq 1.0 \quad \text{--- (14)}$$

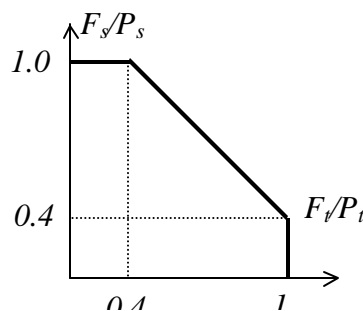

5.4 Block shear

Failure by block shear occurs when a portion of the member tears out in a combination of tension and shear. The equations given for block shear in the chapter on Tension Members are repeated here. The strength as governed by block shear is the minimum of

$$\begin{aligned} & \{ \text{EMBED Equation.3} \} \\ & \{ \text{EMBED Equation.3} \} \end{aligned} \quad (15)$$

Check for block shear should be carried out when using high strength bolts with minimum pitch and edge distances and in coped sections.

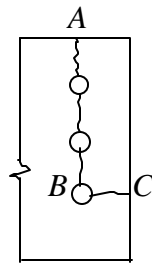

Fig. 11 Block Shear

6.0 SUMMARY

Different types of bolted connections were described and classified. The bearing and friction grip bolts were introduced and their installation procedures described. The force transfer mechanisms were explained and the failure modes and corresponding strength calculations were given. This will help in the design of simple bolted connections as in the worked examples.

7.0 REFERENCES

1. Owens. G.W and Cheal. B.D., (1989): 'Structural Steelwork Connections', Butterworths.

2. Owens G.W and Knowles P.R., (1994): ‘Steel Designers Manual’, The Steel Construction Institute, Blackwell Scientific Publications, ELBS 5th edition.
3. Geschwindner L.F. et al (1994): ‘Load and Resistance Factor Design of Steel Structures’, Prentice Hall, Englewood Cliffs, New Jersey.

Structural Steel Design Project Calculation Sheet	Job No:	Sheet <i>1 of 1</i>	Rev
	Job Title: <i>Bolted Connections</i>		
	<i>Worked Example – 1 Lap joint</i>		
		Made by <i>SRSK</i>	Date <i>15-07-00</i>
	Checked by <i>RN</i>	Date	

Design Example I: Design a Lap joint between plates 65 × 8 as shown in Fig. E1 below so as to transmit a factored load of 45 kN using black bolts of 16mm diameter and grade 4.6. The plates are made of steel of grade ST-42-S.

Remarks

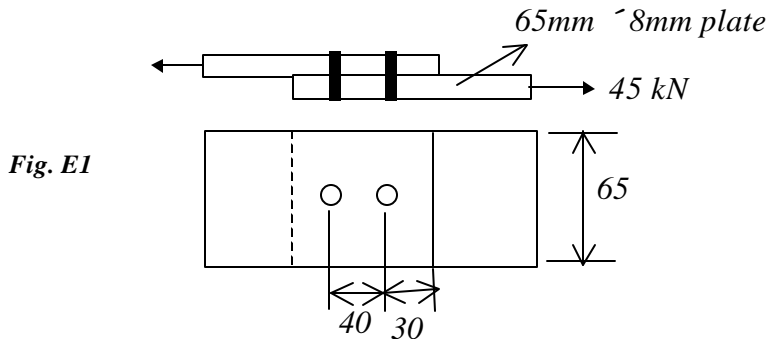

Solution:

1) Strength Calculations:

Nominal diameter of bolt $d = 16 \text{ mm}$,
hole diameter $D = 16 + 1.5 = 17.5 \text{ mm}$

Shear Area of one bolt $A_s = 0.8A = 0.8 \times 201.06 = 161 \text{ mm}^2$

Shear strength of each bolt $= p_s A_s = 160 \times 161 \times 10^{-3} = 25.76 \text{ kN}$

Eq. (7)

Since p_{bb} for bolt is greater than p_{bs} of plate, plate will fail in bearing before the bolt.

Bearing strength of plate $= p_{bs} d t = 418 \times 16 \times 8 \times 10^{-3} = 53.5 \text{ kN}$

Eq. (9)

Therefore, bolt value = 25.76 kN

No. of bolts required $= 45/25.76 = 1.75$ say 2 bolts

2) Detailing:

Minimum pitch $= 2.5 d = 40 \text{ mm}$

Minimum edge distance $= 1.4 D = 24.5 \text{ mm}$ say 25 mm

Provide 2 bolts as shown.

Structural Steel Design Project

Calculation Sheet

Job No:	Sheet 1 of 1	Rev
Job Title: Bolted Connections		
Worked Example – 2 Hanger joint		
Made by	SRSK	Date 15-7-00
Checked by	RN	Date

	Remarks
<p>Design Example 2: Design a hanger joint along with an end plate to carry a downward load of 330 kN. Use end plate size 240 mm x 160 mm and appropriate thickness and M25 HSFG bolts (2 nos).</p>	
<p>Solution</p>	
<p>Assume 10mm fillet weld between the hanger plate and the end plate</p>	
<p>Distance from center line of bolt to toe of fillet weld $b = 60 \text{ mm}$</p>	
<p>1) For minimum thickness design, $M = Tb/2 = 165 \times 60/2 = 4950 \text{ N-m}$</p>	
<p>{ EMBED Equation.3 }</p>	
<p>2) Check for prying forces</p>	
<p>distance 'n' from center line of bolt to prying force is the minimum of</p>	
<p>edge distance or $1.1t \sqrt{b_p/f_y} = 1.1 \times 25 \sqrt{2 \times 510/236} = 57 \text{ mm}$</p>	Eq. (6)
<p>\ $n = 40 \text{ mm}$</p>	
<p>prying force $= M/n = 4950/40 = 123.75 \text{ kN}$</p>	
<p>bolt load $= 165 + 123.75 = 288.75 \text{ kN}$</p>	
<p>tension capacity of 25 mm dia HSFG bolt $= 0.9P_o$</p>	
<p>$= 0.9 \times 195.6 = 176 \text{ kN} \ll 288.75 \text{ unsafe!}$</p>	Eq. (2) Table 3
<p>3) In order to reduce the load on bolt to a value less than the bolt</p>	
<p>capacity, a thicker end plate will have to be used.</p>	
<p>Allowable prying force $Q = 176 - 165 = 11 \text{ kN}$</p>	
<p>Trying a 40 mm thick end plate gives $n = 40 \text{ mm}$ as before</p>	
<p>Moment at toe of weld $= Tb - Qn = 165 \times 60 - 11 \times 40 = 9460 \text{ N-m}$</p>	
<p>Moment capacity $= (236/1.15)(160 \times 40^2/4) \times 10^{-3}$</p>	
<p>$= 13134 \text{ N-m} > 9460 \text{ OK}$</p>	
<p>Minimum prying force</p>	
<p>{ EMBED Equation.3 }</p>	
<p>$= 2.4 \text{ kN} < 11 \text{ kN} \ \backslash \ \text{safe!}$</p>	Eq. (3)
<p>Therefore, 40 mm end plate needs to be used to avoid significant prying</p>	
<p>action.</p>	
<p></p>	
<p></p>	
<p></p>	Eq. (1)

