

## 1.0 INTRODUCTION

A component or a structure, which can withstand a single application of load, may fracture if the same load is applied a large number of times. This type of failure is classified as fatigue fracture. Thus, fatigue failure can be defined as the number of cycles or the time taken to attain a pre-defined failure criterion. A more precise definition of fatigue is given as the process of progressive localised permanent structural change occurring in a material subjected to conditions, which produce fluctuating stresses and strains at some points and which may culminate in cracks or complete rupture after sufficient number of fluctuations. Hence, fatigue phenomenon is experienced by structures, which are subjected to moving loads, such as bridges and crane girders, or structures subjected to cyclic loads such as offshore platform structures and machinery supporting structures.

Fatigue as a failure mechanism was identified initially in the rolling stocks and tracks of railways and subsequently in railway bridges. Recently, fatigue problem has been experienced in highway bridges, with a few failures of bridges. In many instances, due to timely repair measures, catastrophic collapse of structures due to fatigue has been avoided.

The lower the stress ranges i.e., the difference between the alternating maximum and minimum stresses, the larger the number of cycles the structure can withstand before the occurrence of fracture. In the case of fatigue fracture of engineering structures, the following are the two main types of fatigue loading.

- High-cycle low-stress fatigue.
- Low-cycle high-stress fatigue.

In a typical high-cycle fatigue problem, the endurance limit of the material after millions of cycles of load application is of concern, whereas in low-cycle fatigue, fracture before  $10^5$  cycles is the consideration. In high-cycle fatigue problems, the critical portion of the structure is subjected to frequent repeated loads, such as welded tubular joints in steel offshore platform structures subjected to wave loading. In such areas, several million (100 million) cycles are achieved during the lifetime of the offshore structure (about 25 years). An example of low fatigue fracture is the hull structure of a ship. When structural components are exposed to corrosion environment, such as seawater, the synergistic effect of corrosion and fatigue, known as corrosion fatigue becomes a serious problem.

© Copyright reserved

Since fatigue failure evaluation is influenced by a number of uncertainties, an accurate prediction of fatigue life is difficult even for a very simple detail. Fatigue failure prediction is difficult in structural components due to the following uncertain features:

- The effect of environment in which the structure is functioning.
- Difficulty in accurate calculation of internal stresses developed due to external forces at critical locations in the structure
- The time to failure of the structure.

Two basic approaches for fatigue life assessment of structural components are: 1) the  $S - N$  method and 2) the method of fracture mechanics. The  $S - N$  method of life prediction is based on empirically derived relationships between applied stress ranges ( $S$ ) and number of cycles of load application ( $N$ ). The fracture mechanics approach takes into account the crack growth rate of an existing defect as it propagates under the cyclic loading.

In this chapter, topics such as characteristics of fatigue, methods of evaluation of fatigue life, improvement of fatigue resistance, fatigue-resistant design etc. have been covered.

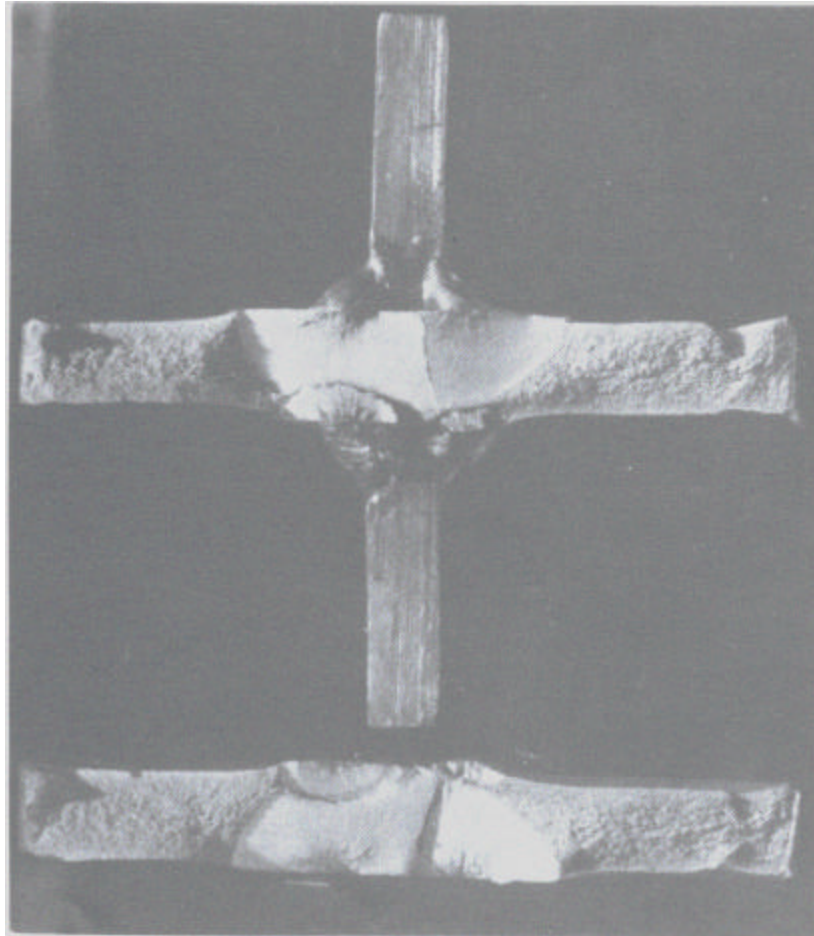
## 2.0 CHARACTERISTICS OF FATIGUE FRACTURE

Structural materials undergo mechanical changes when subjected to cyclic stresses and trigger many engineering failures due to fatigue. Poor design and fabrication are the prime reasons for the failures. A fatigue failure occurs as a result of various mechanisms, which take place in three stages during the life of a structure. As a result of cyclic loading a microscopic defect initiates, then propagates in a gradual manner, resulting finally in an unstable fracture. Cracking originates mostly on the surface at a point of stress concentration – a hole, notch, keyway, scratch, weld bead, sharp fillet etc. Crack initiation may occur, occasionally, at an interior point such as a defect in a weld. In most welded steel structures the crack initiation phase does not exist as crack-like weld defects are invariably present in them. Thus the fatigue life of a connection containing welds is entirely due to crack growth. Final failure usually occurs in a tension region when the reduced section is no more sufficient to carry the peak load.

Many repetitions of the stresses - of the order of millions – may be required for complete rupture. Similarly, the time required for final collapse may be short or many years in some cases. The maximum stress at the fracture location would be well below the value obtained under static loading. It is very difficult to detect a fatigue crack even up to the point of failure. Since there is very little plastic deformation around the crack, there is no evidence of the presence of crack, repeated through large deformation.

A small crack initiated grows slowly with the repetition of stress cycles. A fatigue crack is said to be transgranular i.e., its grows within grains rather than along the grain boundaries. As the crack propagates, the cross-section reduces and the stress on the reduced cross section increases. As a result, there will be an increase in the rate of crack propagation. The final rupture occurs when the remaining area is no longer sufficient to support the applied load.

The above features of fracture due to fatigue can be seen on the fracture surface. The fracture surface may be either crystalline or fibrous depending upon whether the fracture is brittle or ductile. In the close neighbourhood of the crack's origin, the fractured surface has a smooth, silky appearance, which is produced by rubbing of the surface as the crack propagates (Fig.1). The smooth region grows progressively into a rougher texture as the distance from the origin increases. An examination of this surface would reveal the presence of concentric rings or beach markings around the fracture nucleus and radial lines emanating from it.



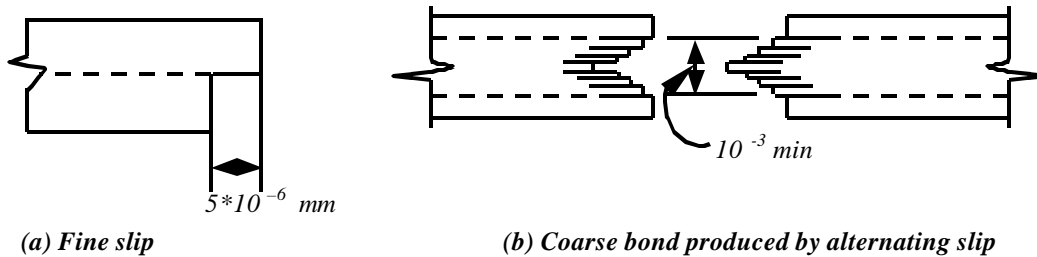
*Fig.1 Fractured surface of a specimen*

### **3.0 THE MECHANISM OF FATIGUE**

Presently there is no rational theory available for fatigue failure prediction relating stresses and material properties. This is due to the complex mechanism involved in the fatigue process. The mechanism of fatigue is explained briefly in the following.

Due to stress concentration effects, the stress in a localised region in a structural element may attain the value needed for plastic flow. The nominal stress or the stress without concentration effects may be below the proportional limit. At this stage, slip might occur in an unfavorably oriented crystallographic plane due to excessive shear stress on the

plane. This might be a fine slip i.e., a slip of order  $10^{-6}$  mm below adjacent region of the crystal [Fig.2 (a)]. The reversal of stress at this time might partially set right the disorientation. Repetition of the stress cycle and the resulting back and forth slip on closely spaced parallel planes will cause slip band to develop [Fig.2 (b)]. This would form a notch. A microscopic crack may form because of the stress raising effect of the notch or the notch itself becomes deeper. Once the crack has formed, the process is further intensified.



**Fig. 2 Fatigue mechanism**

#### 4.0 FACTORS INFLUENCING FATIGUE BEHAVIOR

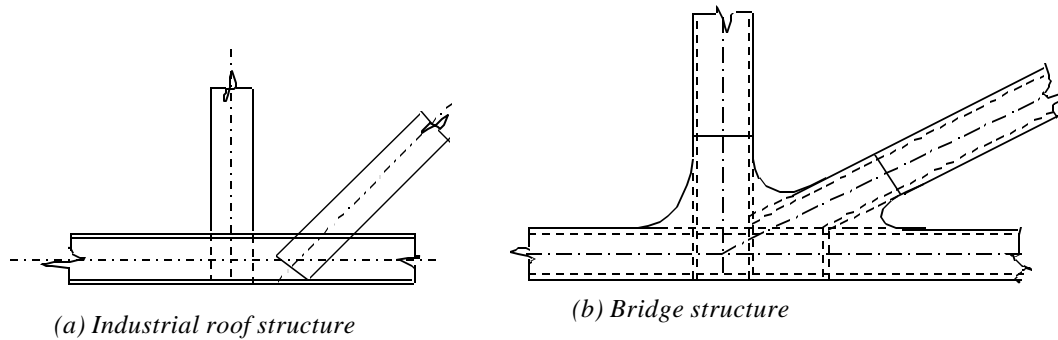
The fatigue behavior of various types of structures, members and connections is affected by a large number of factors, many of which may produce interrelated effects. The parameters that influence fatigue behavior are: stress range, material, stress concentration, rate of cyclic loading, residual stresses, size, geometry, environment, temperature, and previous stress history. These are explained briefly in the following.

##### 4.1 Stress range

The most important factor governing the rate of crack growth is the stress range in the vicinity of the crack tip. Hence in a fatigue design, the stress concentration effect has to be reduced and the stress range has to be realistically estimated. The importance of stress concentration is brought out in detail in the following section.

##### 4.2 Stress concentration

The geometry and the consequent stress concentration have a large impact on fatigue lives of structural members and their connections with other members. Stress distribution is generally different from that adopted in design mainly due to stress concentration. Such points of stress concentration under cyclic loading undergo reduction in strength, often leading to fracture. The importance of stress concentration is illustrated in Fig.3. In Fig.3 (a), typical detail of a connection in an industrial roof structure is shown. Here the design is mainly governed by static strength. The local stress at the connection could be 5 to 10 times the average stress calculated by the simple theory for static design. The structure, by way of local yielding, accommodates safely the discontinuities and stress concentration. Fig.3 (b) shows a fatigue-sensitive bridge structure connection detail.



**Fig. 3 Typical connection details**

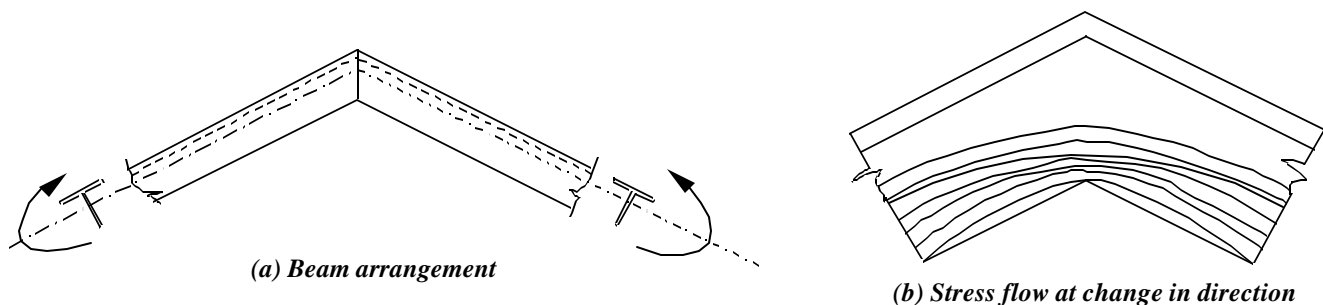
Here, stress concentration has to be reduced by careful design. Detailed design considering both primary axial stress and secondary bending stress has to be performed. Weld profiling should be smoothed to minimize local discontinuities. It is appropriate now to consider three levels of stress concentration.

#### 4.2.1 Structural action

In the static analysis of a structure, elastic analysis is carried out based on compatibility concepts. The relative deformation between neighboring elements is often ignored. These local deformations develop additional strains and stresses. Secondary members, whose effects are often ignored in the static analysis, develop stresses due to the relative deformation in neighbouring elements. These additional stresses cause stress concentration. In the roof connection shown in Fig.3 (a), a simple static design would ignore the incompatibility that is caused by the restraint to the end rotation of the individual elements. The resulting bending stresses may be of similar magnitude as axial stresses in a truss with larger size sections. Therefore, in a fatigue design these bending stresses must be considered.

#### 4.2.2 Macroscopic stress concentration

This type of stress concentration arises due to geometric interruptions to stress flow. The smooth flow of stress trajectories are modified due to changes in cross section, notches, holes and other discontinuities. Fig. 4 shows a discontinuous structure with the attendant stress concentration effect.

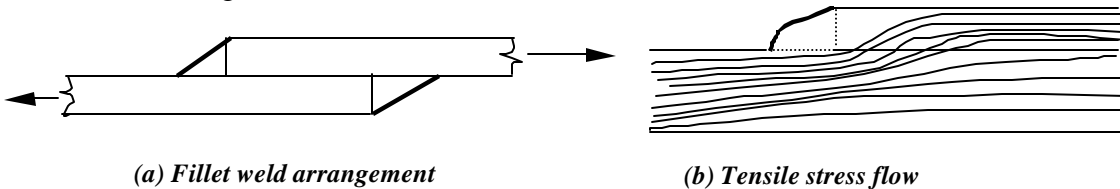


**Fig. 4 Bending stresses in a discontinuous beam**

### 4.2.3 Local geometric stress concentration factor

This level of stress concentration is related to crack tip effects and other microscopic defect. They occur generally within a weld or Heat Affected Zone (HAZ) [Fig. 5(a)]. Due to the sharpness of these defects, the stress concentration effect will be mostly localized.

The stress trajectories through welds are affected by the structural action of the weld, by its geometry, surface roughness and by the relative position of the joined elements. These are shown in Fig. 5 (b).



**Fig. 5 Stress concentration at the toe of a fillet weld**

### 4.3 Frequency of Cyclic Loading

The frequency of loading does not influence fatigue strength significantly when the applied stress range is low and frequency is less than 50 Hz. But when the stress range is high capable of producing plastic deformation with each cycle of loading (low cycle fatigue) an increase in frequency produces an increase in apparent fatigue strength.

### 4.4 Residual stresses

The effect of residual stress varies considerably, depending upon the material, state and magnitude of residual and applied stresses. The effect of compressive residual stress generally is to increase the fatigue resistance for lower levels of stress. But for higher levels of stress close to yielding, its effect is negligible. The residual tensile stresses do not affect fatigue resistance except in cases where residual tension reduces the stress range in cyclic loading.

### 4.5 Size

In the case of small members subjected to flexure, the fatigue resistance increases due to the small size and the resulting increase in strain gradient. For large flexural members and axially loaded members the size effect is very small.

### 4.6 Material

In general the fatigue resistance of structural steel is proportional to its ultimate strength. Tests have shown that under ideal conditions, fatigue limit is approximately 50% of ultimate stress. However, other factors may considerably alter this fatigue limit.

The general relation between fatigue limit and ultimate stress is given below

$$F_1 = 140 + 0.25 F_u \quad (1)$$

where  $F_l$  = fatigue limit for zero to maximum tensile loading in  $Mpa$

$F_u$  = ultimate stress of the material in  $MPa$

## 5.0 EFFECT OF FATIGUE LOADING ON STRUCTURAL MEMBERS AND WELD CONNECTIONS

Fatigue behaviour of axially loaded tension and compression members are quite different. Compressive cyclic loading will not generally produce fatigue failure, except when tensile stresses are present. The fatigue behavior of tensile members is generally decided by their connections, except where the member itself has points of stress concentration. Properly detailed and fabricated flexural members have a higher fatigue resistance. Welded details such as cover plate, splices, and stiffeners reduce the fatigue resistance significantly.

Welds invariably contain small crack-like defects; hence crack initiation stage does not exist. Only the number of cycles for the crack to grow to the point of unstable fracture constitutes the fatigue life. Residual stresses of yield stress level are always present in the vicinity of welds. Therefore stress cycling is always from the yield stress downwards and fatigue life is a function of stress range only. Fatigue life varies with the type of weld details due to the varying nature of the defects in the different details.

Welded connections have comparatively lower fatigue resistance, if they are not properly detailed and fabricated. The most important factor that influences the fatigue resistance of welded joint is the geometry and the resulting stress concentration effects. Fatigue failure at a welded joint may occur in any one or combination of the following.

- Failure in the deposited metals from the porosity or slag inclusions and defect locations, which act as stress concentration points.
- Failure in the line of fusion, due to lack of proper fusion or microscopic cracks.
- Failure in the heat affected zone due to crystalline change in the base metal.
- Failure at the toe edge of the weld, which is a stress concentrated point due to the joint design, weld contour undercut, etc.

The importance of smooth stress flow through a joint has been emphasized elsewhere. Butt-welded joints, where the stress flow is smooth, have much better fatigue resistance compared to fillet welded joints. The fatigue strength of a butt-welded connection may be further improved by finishing the weld flush with the surface of the plate by grinding.

## 6.0 FATIGUE ANALYSIS

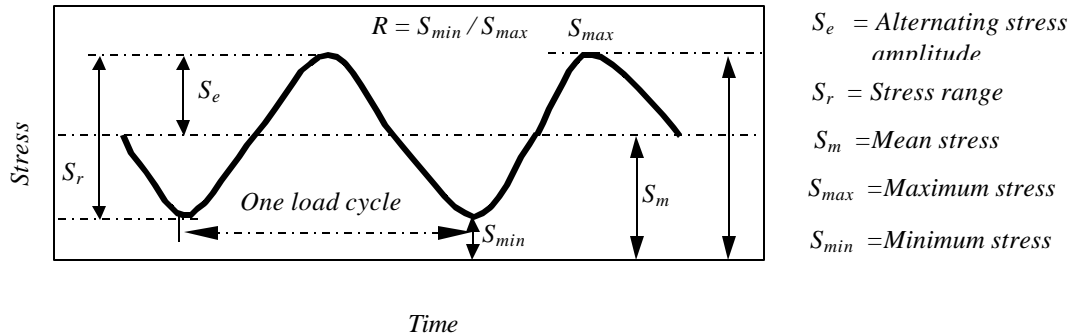
### 6.1 General

Generally, structures are designed for strength and deflection criteria. In the case of structures prone to fatigue effects, a fatigue analysis is carried out to ensure that the fatigue life of the structure is more than the intended life of the structure. Fatigue analysis involves determination of nominal stresses in structural members, stress concentration factors at critical points and safe number of stress reversals before the onset of failure.

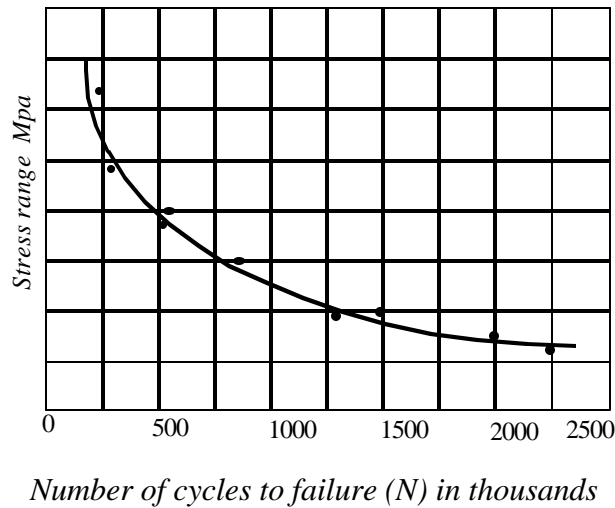
The two main approaches to fatigue life determination, namely, the  $S - N$  curve method and the fracture mechanics method are explained in this section.

### 6.2 S – N Curves

Fatigue data is commonly presented in the form of an  $S - N$  curve, where the cyclic stress range ( $S$ ) is plotted against the number of cycles to failure ( $N$ ). Various parameters of interest in fatigue are shown in Fig. 6. A typical  $S - N$  curve is shown in Fig. 7.

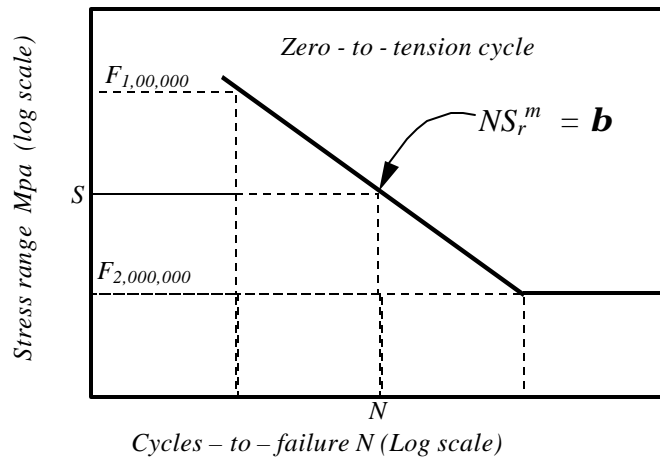


**Fig. 6 Various parameters in fatigue**



**Fig.7 S – N Curve (Wohler curve)**

In order to determine the fatigue strength of a welded joint configuration, under a given load condition, it is necessary to test a series of similar specimens. Each of the specimens is subjected to constant amplitude loading and the number of loading cycles required to produce failure in each specimen is recorded. The relationship between the applied stress,  $S$  and the number of cycles to failure,  $N$ , is obtained. Logarithmic scales are commonly used for both axes, namely,  $LogS - LogN$  (Fig.8). Because  $LogS - LogN$  relationship for many materials is approximately linear, most fatigue data are presented as log – log relationships.



$F_{1,00,000}$  = fatigue strength for 100,000 Cycles

$F_{2,000,000}$  = fatigue strength for 200,000 Cycles

**Fig. 8 S – N Curve presented on a log-log scale**

For welded joints the relationship between fatigue life and applied stress range is linear over a wide range of stress and takes the form

$$N S_r^m = \mathbf{b} \quad (2)$$

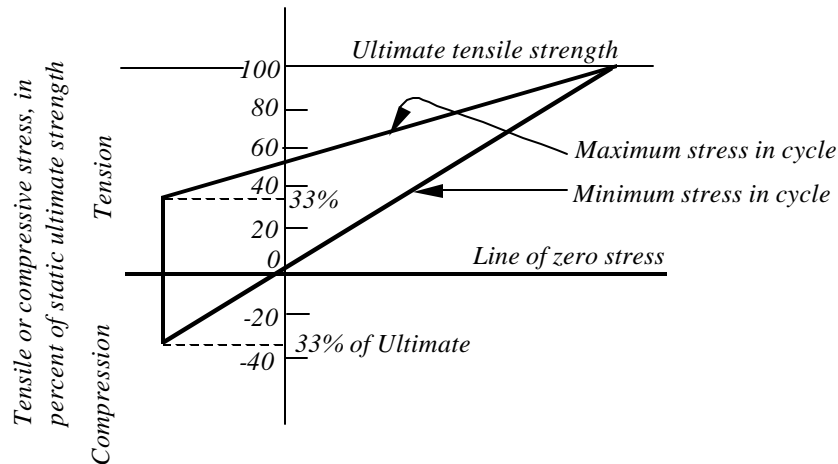
where  $N$  = number of cycles to failure,  $S_r$  = applied stress range and  $m$ ,  $\mathbf{b}$  = constants depending upon the joint type.

Using such a relationship, the fatigue strength can be calculated over the range covered by the sloping line for any selected number of cycles of the same type of stress cycle, if the slope of the line and one point on the line are known. Only one type of stress cycle is represented by each  $S - N$  curve. For understanding the general behaviour of a joint, it is necessary to develop  $S - N$  curve for each type of stress cycle.

The data for the various  $S - N$  curves are summarized in a Goodman's Diagram. Fig. 9 shows a Goodman's diagram for an as-rolled plate. It provides a complete representation of the effects of various types of stress cycles, from static tension, zero to tension and complete reversal.

In the Fig.9, the range of stress (maximum stress to minimum stress) is indicated by the vertical distance between the two sloping lines. At the extreme left side, the stress range is complete reversal from a compressive stress to a numerically equal tensile stress. At the extreme right side, the maximum stress line intersects the minimum stress line at the level of ultimate strength, and the stress range is zero (this representing the static yield stress). At the point where the minimum stress line intersects the zero stress line, the maximum stress represents fatigue strength under a pulsating load (zero to tension).

In any welded joint there are at least five locations at which fatigue cracks may initiate. These are at the weld toe in each of the two points joined, at the two ends and in the weld itself. Each is classified separately.



**Fig.9 Goodman diagram – a composite representation of the effects of various types of stress cycles on fatigue life**

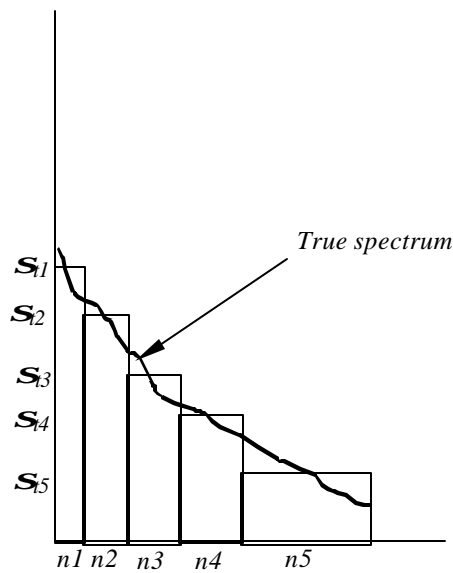
### 6.3 Variable Amplitude Loading

So far, fatigue loading has been considered as a single fluctuating load of constant amplitude producing constant stress range. In practice, it is common for structures to be subjected to more than one type of loading and each type of loading may vary in intensity, i.e. they may be subjected to a loading spectrum of varying amplitudes or random vibrations. In situations where variable stress history is encountered, the sequence is broken into a stress range spectrum as shown in Fig. 10. In order to do this, cycle counting methods, such as Reservoir Method (for short stress histories by hand calculations) and the Rainflow Method (for analysing long stress histories by computer) are employed.

For structures subjected to variable amplitude of stresses, fatigue life has to be estimated by calculating the damage due to each band of the stress spectrum and summing them. The damage due to each band is  $n / N$ , where  $n$  is the number of cycles in the stress range during the design life and  $N$  is the endurance limit over that stress range. Palmgren – Miner rule is invoked to determine the failure of the joint. It states that to prevent failure the damage done by all the stress ranges must not exceed unity

$$n_1 / N_1 + n_2 / N_2 + n_3 / N_3 + \dots + n_n / N_n \leq 1.0 \tag{3}$$

In the case of variable amplitude loading, even non – propagating stress ranges (below fatigue limit) will also cause damage. The cracks formed under higher amplitude stress ranges will continue to propagate because the enhanced stress range at the crack tip (due to stress concentration) will be sufficient to continue the propagation even for very nominal stress ranges.



**Fig. 10 Stress range spectrum**

**6.4 Fracture Mechanics Analysis**

Fracture mechanics discipline, dealing with the behavior of cracks in materials and structures, has recently been employed for fatigue life assessment. Here the presence of defects or cracks is explicitly taken into account. A parameter is defined to represent the state of stress at the tip of the crack, called the stress intensity factor ( $K$ ). This is represented in the following form

$$K = Y \mathbf{s} (\mathbf{p} a)^{1/2} \tag{4}$$

where,  $Y$  = geometric correction factor  
 $\mathbf{s}$  = nominal stress  
 $a$  = crack length.

Fatigue life assessment by fracture mechanics is based on the observed relationship between the stress intensity factor range { EMBED Equation.3 } and rate of growth of fatigue cracks  $da / dN$ . This approach was proposed by Paris and Erdogan in a power law form for metallic materials in the Journal of Basic Engineering (1963), and is summarised below:

$$\{ \text{EMBED Equation.3} \} \tag{5}$$

where { EMBED Equation.3 } = crack extension per cycle  
 $C, m$  = crack growth constants, and

{ EMBED Equation.3 } =  $K_{max} - K_{min}$  are the maximum and minimum stress intensity factors respectively in each cycle. The exponent  $m$  has a value in the range of 3-4. Since

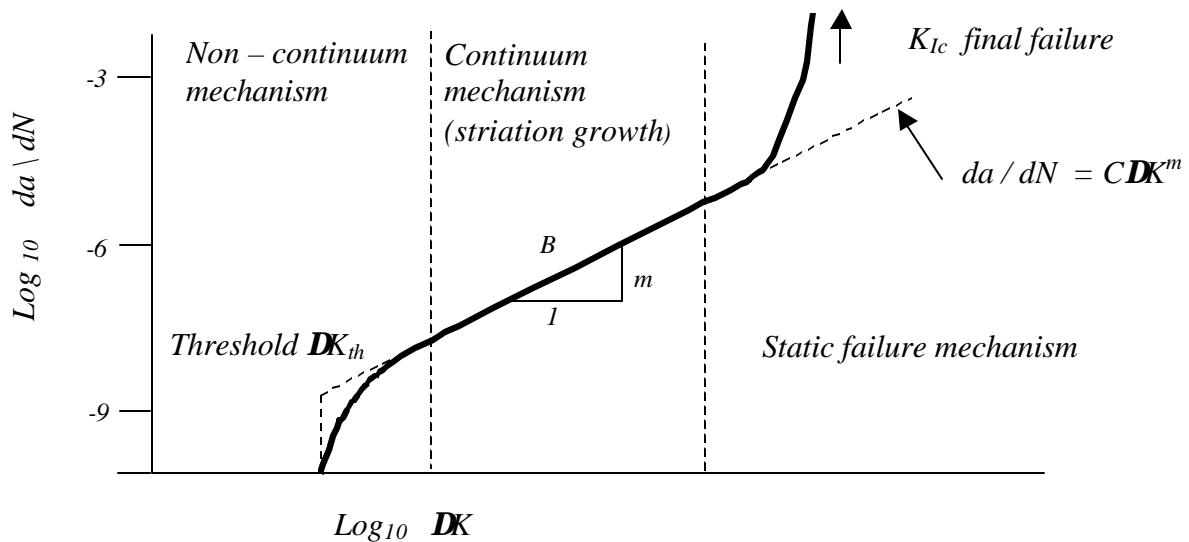
the crack growth rate is related to { EMBED Equation.3 } raised to the exponent, determination of { EMBED Equation.3 } becomes crucial for meaningful crack growth prediction. Values of  $C$  and  $m$  can be determined by conducting tests on the materials being used. Typical values of  $C$  and  $m$  for ferrite steel are:

$$m = 3$$

$$C = 3 \cdot 10^{-13} \text{ for normal environment up to } 100^{\circ} \text{C.}$$

$$C = 3 \cdot 10^{-12} \text{ for aggressive environment up to } 200^{\circ} \text{C.}$$

If a typical  $da / dN$  versus { EMBED Equation.3 } relationship is plotted on a log-log scale, sigmoidal curve is obtained as shown in Fig.11. Below a threshold value of stress intensity factor range { EMBED Equation.3 }<sub>th</sub>, crack growth does not occur. For intermediate values of { EMBED Equation.3 } the growth rate is approximately linear.



**Fig. 11 Schematic representation of crack growth**

For a crack at the toe of a welded joint, stress intensity factor range can be expressed as

$$\{ \text{EMBED Equation.3} \} \{ \text{EMBED Equation.3} \} = \{ \text{EMBED Equation.3} \} \quad (6)$$

where,  $M_k$  = A factor representing stress concentration effect depending up on crack size, plate thickness, joint geometry and loading.

$Y$  = Correction factor, which depends up on the crack size, shape and loading.

$DS_r$  = Applied stress range.

$a$  = Crack depth.

The fatigue strength of the joint can be predicted by substituting Eqn. (6) in Eqn. (2). Rearranging and integrating we get

$$\{ \text{EMBED Equation.3} \} \quad (7)$$

where,  $a_i$  = initial crack depth and  $a_f$  = the final crack depth corresponding to failure. Hence if a welded joint contains a crack, the above equation can be used to predict its fatigue life, considering that it consists of crack growth from the initial size, which is assumed as known.

## **7.0 INDIAN STANDARD PRACTICE**

### **7.1 General**

Indian standard IS: 1024 – 1979 “Code of Practice for Use of Welding in Bridges and Structures Subjected to Dynamic Loading” covers the use of metal arc welding in bridges and structures subjected to fatigue loading. It has presented guidelines for the design of structures under fatigue environment.

### **7.2 Loading**

Working stress should be reduced to allow for the effects of fatigue. Allowance for fatigue should be made for combination of stresses due to dead load, live load, and impact load including secondary stresses due to eccentricity of connection etc. Elements of a structure may be subjected to a very large variety of stress cycles both in range and magnitude. Each element of the structure must be designed for the number of cycles of different magnitudes of stress to which the element is to be subjected during the expected life of the structure. Since the fatigue strength of a welded structure depends upon the type and location of joint details, these should be decided in advance in order to arrive at the permissible stresses under repeated loading. For the purpose of determining the allowable stresses the details are classified into seven classes. IS:1024-1979 gives values of allowable number of stress cycles for different values of stress ranges for the various classes of construction details which are described below.

### **7.3 Classes of Welded Construction Details**

#### **Class A**

- (1) Members fabricated with continuous full penetration longitudinal or transverse butt welds with the reinforcement dressed flush with the plate surface are classed as A. It is a requirement that the weld should be proved free from defects by non-destructive examination. Further, the members should not have exposed gas cut edges.
- (2) Welds should be dressed flush by machining or grinding, or both, which should be finished in the direction parallel to the direction of applied stress.

#### **Class B**

- (1) Members fabricated with the continuous longitudinal butt welds with full penetration made with either submerged or gas shielded metal arc automatic process but with no intermediate start-stop positions within the weld length are classed B.

- (2) Members fabricated with continuous longitudinal fillet welds made with either submerged or gas shielded metal arc automatic process but with no intermediate start-stop positions within the weld length are also classed B.

### Class C

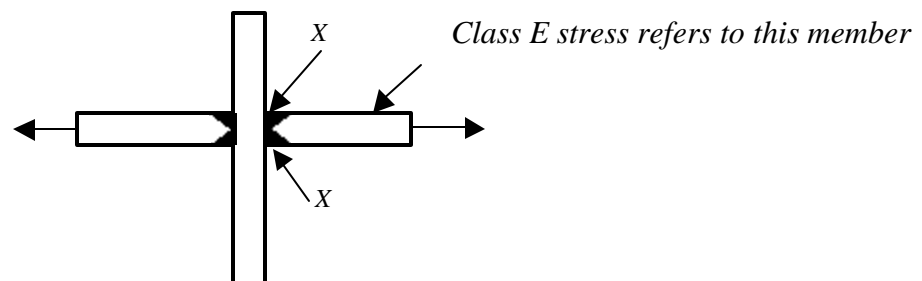
Members fabricated with continuous longitudinal butt welds including fabricated beams with full web penetration of the web to flange welds, with start-stop position within the length of the weld are classed C.

### Class D

- (1) Members fabricated with full penetration transverse butt welds made in the shop by manual welding with electrodes other than deep penetration electrode, providing that all runs are made in the down hand position and that there is no undercutting are classed D. This does not include welds made on a backing strip if the backing strip is left in the position.
- (2) Members fabricated with full penetration transverse butt welds, other than those in (1), and having the weld reinforcement dressed flush and with no undercutting.
- (3) Members with continuous longitudinal fillet welds with start-stop positions within the length of the weld.

### Class E

- (1) Members fabricated with transverse butt welds, other than those mentioned in class D(2), or with transverse butt welds made on a backing strip are termed class E.
- (2) Members fabricated with full penetration cruciform butt welds (Fig. 12) are also classed E.



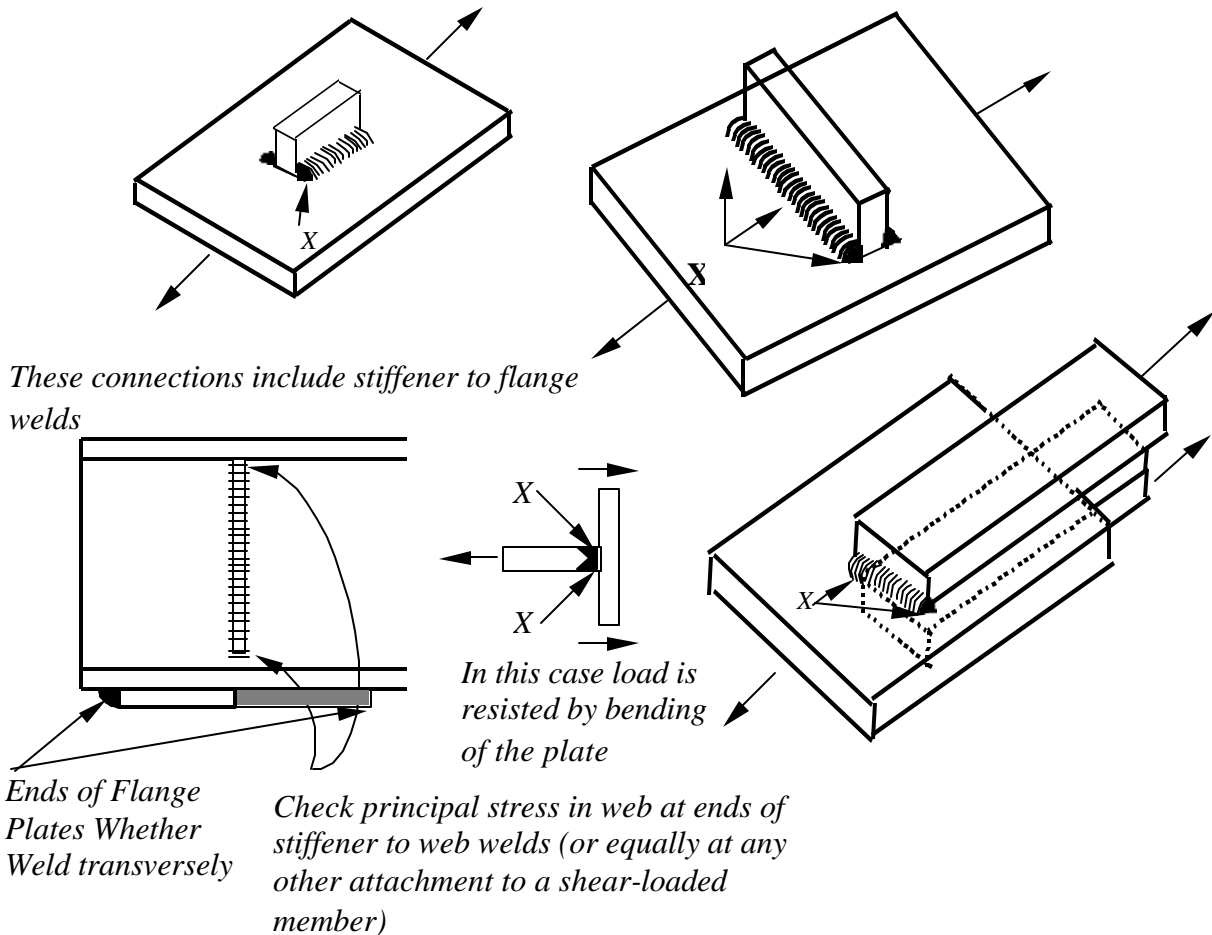
*Fig.12 Class E fulls penetration cruciform butt weld.*

### Class F

The following categories are classed F:

- (1) Members with T type full penetration butt welds (Fig.13).

- (2) Members with intermittent longitudinal or transverse non-load carrying fillet or butt welds, except for the details covered in class G (Fig.13).
- (3) Members connected by transverse load carrying fillet welds.
- (4) Members with stud connectors.

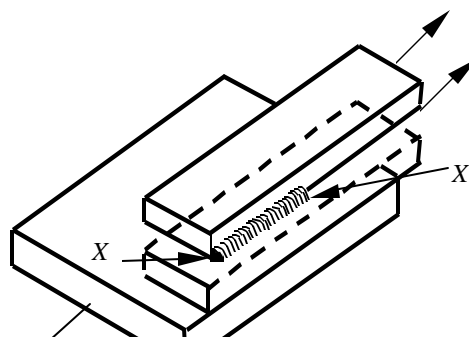


**Fig. 13 Typical class F weld details**

**Class G**

The following categories are classed G

- (1) Members connected by longitudinal load carrying fillet welds [Fig. 14(a)].
- (2) Members connected by load carrying cruciform fillet welds [Fig. 14(b)].
- (3) Members with intermittent non-load carrying fillet or butt welded attachments on or adjacent to their edges [Fig. 14(c)].



For each of the stress ranges, the maximum allowable number of cycles  $N_1, N_2, \dots, N_n$  should be determined from the tables given in the IS Code 1024 - 1979.

Considering the expected number of cycles for each stress level as  $n_1, n_2, \dots, n_n$ , the element should be so designed such that

$$n_1/N_1 + n_2/N_2 + n_3/N_3 + \dots + n_n/N_n > 1.0 \quad (8)$$

### Permissible stress in welds

Permissible stresses have been specified for butt and fillet welds. Butt and fillet welds are treated, as parent metal with thickness equal to throat thickness and the stresses should not exceed those in the parent metal. For fillet welds, the permissible stress in the fillet

welds should not exceed the permissible values given in IS: 1024-1979 and reproduced here.

For combined shear and bending stresses, the equivalent stress  $f_e$  is given by:

$$f_e = \{ \text{EMBED Equation.3} \} \quad (9)$$

$f_{bt}$  = tensile bending stress.

$f_{bc}$  = compressive bending stress.

$f_q$  = shear stress.

**Table-1 Permissible shear stresses**

Steel conforming to	Permissible shear stress in Mpa
IS: 226 – 1975 IS: 2062 – 1969	108
IS: 961 - 1975	131

For combined shear, bearing and bending stresses, equivalent stress is given by:

$$f_e = \{ \text{EMBED Equation.3} \} \quad (10)$$

The equivalent stress  $f_e$  should not exceed  $0.9F_y$  where  $F_y$  is the yield strength of the steel. The value of  $f_e$  for various steels and yield strengths are given in Table 2.

**Table 2 Equivalent stress,  $f_e$**

Steel conforming to	$F_y$ (Mpa)	$f_e$ (Mpa)
IS: 226-1975 and IS:2062-1969	230	215
	240	225
IS: 961-1975	250	230
	280	245
	330	295
	340	310
	350	330

## 8.0 IMPROVEMENT OF FATIGUE STRENGTH AND REMEDIAL TECHNIQUES

The fatigue performance of a connection can be improved by using weld improvement techniques. Presently, there are no practical design rules for the improvement techniques. It is recommended that no advantage be taken of these improvements in the initial design. The designer may fall back upon their contribution in case of severity of design fatigue condition or unsatisfactory service behaviour. Though steels are manufactured with excellent weldability, the low fatigue strength of a welded connection is mainly due to the short crack initiation period. Crack initiation life can be extended by

- Reducing the stress concentration of the weld.
- Removing crack-like defects at the weld toe.
- Reducing tensile welding residual stress or introducing compressive stresses.

The various methods of improvements can be classified into:

- *Weld geometry improvement* by grinding, weld dressing and profile control.
- *Residual stress reduction* by peening and thermal stress relief

Much of the current information on weld improvements has been derived from tests on small-scale specimens. In real structures, there will be large residual stresses that may affect fatigue life. Whereas peak stresses develop at the weld toe of a small joint, in a large multi-pass joint, peak stress may occur in any of the several beads and cracks initiate anywhere in this region. Brief details of some of the weld improvement techniques are summarized below.

### **8.1 Weld toe grinding**

In cases where fatigue cracks tend to grow from the toe of welds in single-pass welding or at the junction between beads in multi-pass welding, 30% improvement in fatigue strength can be achieved by grinding the weld toe for the former and the entire region for the latter. A factor of 2.2 can be taken for the fatigue life. The purpose of grinding is to remove the small cracks that are invariably present and act as initiators for future fatigue crack growth. These small sharp cracks are generally 0.5mm deep. The treatment should produce a smooth concave surface to the weld toe with a depth of at least 0.5mm below the bottom of any visible undercut. In fillet-weld connections, the application of grinding should not result in any reduction in the throat area designed. Where fatigue crack may grow from the weld root (such as in a partial penetration weld) there will be no improvement in the fatigue life using this technique.

### **8.2 Weld dressing and profiling**

The profile of a fillet weld is smoothed by dressing. This method is used where the design is very fatigue-sensitive and the costs of repair of fatigue damage would be very high. The technique is used especially in welded steel offshore platforms.

### **8.3 Weld toe remelting**

Weld toe remelting has been found to increase the fatigue strength. This is achieved by providing a low contact angle in the transition between the plate and the weld. This also removes slag inclusions and undercuts at the toe.

Weld toe remelting either by TIG or Plasma Arc Dressing involves remelting the weld toe region with a torch held at angle of  $50^{\circ}$  or  $90^{\circ}$  to the plate. No fillet material is used in the process. The difference between the TIG and Plasma Arc Dressing is in the higher heat input required by the latter.

## 8.4 Hammer peening

Peening is the application of repeated hammering, often with a round-headed punch or hammer, to produce local yielding of the material. The hammering is applied to the weld toe or other locations, where fatigue cracks are likely to initiate. It has the effect of reducing the local residual stresses. Peening reduces the mean stress and therefore improves fatigue life. The improved fatigue properties are due to;

- Introduction of high compressive residual stresses.
- Flattening of crack-like defects at the toe.
- An improved toe profile.

Weld improvement techniques improve the fatigue life of weldments considerably.

## 8.5 Repairs to cracked welds

Repair requirements for cracked welds would be different for different circumstances and cannot be generalized. But the following general comments may be kept in mind while planning the repair of welds.

- Cracks, which may be present act as stress raisers.
- The repaired weld at the field location, done in harsh environment, might contain defects and will have a lower fatigue life.
- The repaired weld should be to a revised detail having a better fatigue classification than the original one.
- Additional stiffening or reinforcing should be provided to reduce the stress range on the detail where the crack has occurred.

## 9.0 FATIGUE-RESISTANT DESIGN

Bridges, offshore structures, towers and cranes are some of the major structures, which require consideration for fatigue design. The adverse effects of fatigue in these complex structures has been observed extensively and today there are efficient analytical tools available to calculate their fatigue lives. Fatigue life of a structure can be predicted with accuracy, if the loading sequences on the structure for the whole of its life is known fairly well; then the specific fatigue-critical locations can be identified and detailed inspections carried out.

In general, for welded structures subjected to fatigue loading, particular attention must be paid to welded joints. Fatigue and brittle fractures can start at discontinuities of shape, notches and cracks, which help develop high local stress. Fatigue life can be considerably increased by avoiding local peak stresses by good design and detailing. A good design should also take into account the fabrication procedure to be adopted for the structure.

Repairs of in-service structures are quite expensive and may even require closing down of the facility. Proper attention is required when providing secondary attachments to main steelwork. These attachment details are usually not given attention during the design as they are not very complicated. A number of failures due to fatigue crack growth has been

observed from weld attachment in offshore structures. General suggestions are listed below for guidance while designing a welded structure with respect to fatigue strength.

- Adopt butt or single and double bevel butt welds in preference to fillet welds.
- Use double-sided in preference to single sided fillet welds.
- Aim to place weld, particularly toe, root and weld end in area of low stress.
- Avoid details that produce severe stress concentration or poor stress distribution.
- Provide gradual transitions in sections and avoid reentrant notch like corners.
- Avoid abrupt changes of section or stiffness of members or components.
- Avoid points so as to eliminate eccentricities or reduce them to a minimum.
- Avoid making attachments on parts subjected to severe fatigue loading. If attachments in such locations are unavoidable, the weld profile should merge smoothly into the parent metal.
- Use continuous rather than intermittent welds.
- Avoid details that introduce localized constraints.
- During fabrication, carry out necessary inspection to ensure proper deposition of welds.
- Provide suitable inspection during the fabrication and erection of structures.
- Intersection of welds should be avoided.
- Edge preparation for butt welding should be designed with a view of using minimum weld metal so as to minimize warping and residual stress build up.
- Ask for pre and post heating, if necessary, to relieve the build up residual stresses.
- Fillet welds carrying longitudinal shear should not be larger in size than necessary from design consideration.
- Deep penetration fillet welds should be used in preference to normal fillet welds.
- Structures subjected to fatigue loading especially in critical locations should be regularly inspected for the presence of fatigue cracks and when such cracks are discovered, immediate steps should be taken to prevent their further propagation into the structure.
- Any repair measures taken should be designed to avoid introduction of more severe fatigue condition.
- Provide multiple load path and / or structural redundancy in the structure to avoid overall collapse of the structure due to failure of one element in the structure in fatigue.
- Provide crack arresting features in the design at critical locations to avoid propagation of cracks into the entire structure.

## 10.0 CONCLUSIONS

In this chapter, various factors affecting fatigue behaviour of welded connections have been explained. The nature of fatigue in welded connections and its critical importance are emphasised. Methods of evaluating fatigue lives of welded connections are described. Techniques for improvement in fatigue performance are presented. Fatigue-resistant design and Indian Standard codal provisions are also included.

## 11.0 REFERENCES

1. Masubuchi K., 'Analysis of welded structures', Pergammon Press, New York, 1980.
2. Owens G.W. and Cheal B.D., 'Structural Steelwork Connections', Butterworths, London, 1989.
3. Owens G.W, Knowles P.R. and Dowling P.J, Steel Designers' Manual, (Fifth Edn.) Blackwell Scientific Publications, London, 1992.
4. IS:1024-1979, 'Code of Practice for Use of Welding in Bridges and Structures Subjected to Dynamic Loading', Bureau of Indian Standards.
5. Paris P. and Erdogan F., 'A critical analysis of crack propagation laws', Journal of Basic Engineering, Dec. 1963, pp. 528-534.