

STEEL BEAMS WITH WEB OPENINGS

1.0 INTRODUCTION

The responsibility of a Structural Engineer lies in not merely designing the structure based on safety and serviceability considerations but he also has to consider the functional requirements based on the use to which the structure is intended. While designing a power plant structure or a multi-storeyed building, the traditional structural steel framing consists of beams and girders with solid webs. These hinder the provision of pipelines and air conditioning ducts required for satisfactory functioning for which the structure is put up. Very often, the service engineer who is on the scene long after the structural erection has been completed is required to fix air conditioning ducts in place. The re-routing of services (or increasing the floor height at the design stage for accommodating them) leads to additional cost and is generally unacceptable. The provision of beams with web openings has become an acceptable engineering practice, and eliminates the probability of a service engineer cutting holes subsequently in inappropriate locations.

Beams with web openings can be competitive in such cases, even though other alternatives to solid web beams such as stub girders, trusses etc are available. This form of construction maintains a smaller construction depth with placement of services within the girder depth, at the most appropriate locations.

The introduction of an opening in the web of the beam alters the stress distribution within the member and also influences its collapse behaviour. Thus, the efficient design of beams and plate girder sections with web openings has become one of the important considerations in modern structures.

In this chapter, methods to evaluate the ultimate shear capacity of the beams and fabricated girders with circular or rectangular web openings are discussed. The methodology is based on the Von Mises yield criterion.

2.0 GUIDELINES FOR WEB OPENINGS AND STIFFENERS

The shape of the web openings will depend upon the designer's choice and the purpose of the opening. There are no hard and fast rules to dictate the shapes of the openings. But, for designer's convenience, openings of regular shapes (such as circular or rectangular) are usually chosen. Introduction of openings in the web decreases stiffness of the beams resulting in larger deflections than the corresponding beams with solid webs. The strength of the beams with openings may be governed by the plastic deformations that occur due to both moment and shear at the openings.

© Copyright reserved

The strength realised will depend on the interaction between the moment and shear. The moment capacity of the perforated beam will be reduced at the opening because of the reduction in the contribution of web to the moment capacity. This is not very significant, as usually the contribution of the web to the moment capacity is very small.

However, the reduction in shear capacity at the opening can be significant. Therefore the ultimate capacity under the action of moment and shear at the cross section where there is an opening will be less compared to that at the a normal cross section without opening. i.e. some strength is lost. To restore the strength lost, reinforcement along the periphery of the openings could be provided. As a general rule, we should avoid having openings in locations of high shear, nor should they be closely spaced. Common types of web openings with and without reinforcement are shown in Fig. 1. The following general design guidelines may be useful [Fig. 2 (a)].

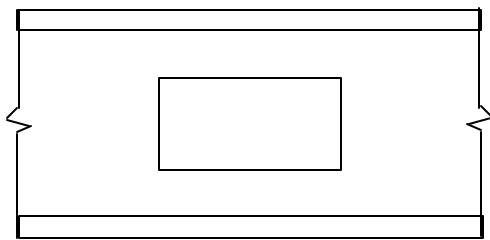

(b) Web with centrally placed rectangular hole

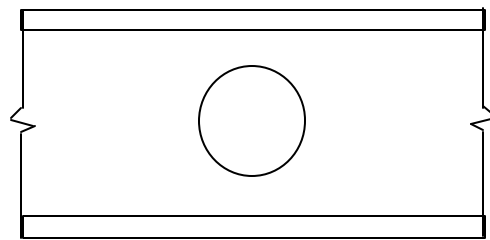

(b) Web with centrally placed circular hole

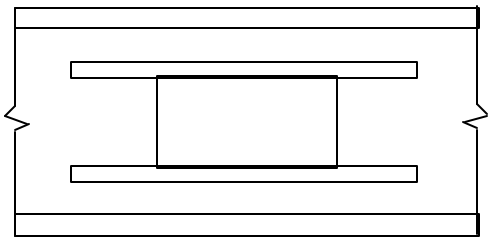

(c) Web with centrally placed rectangular hole with reinforcement

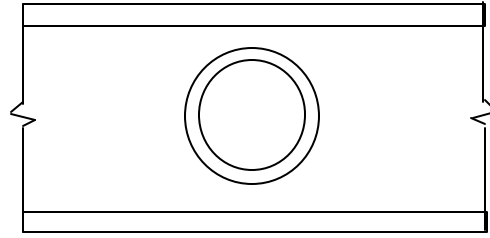

(d) Web with centrally placed circular hole with reinforcement

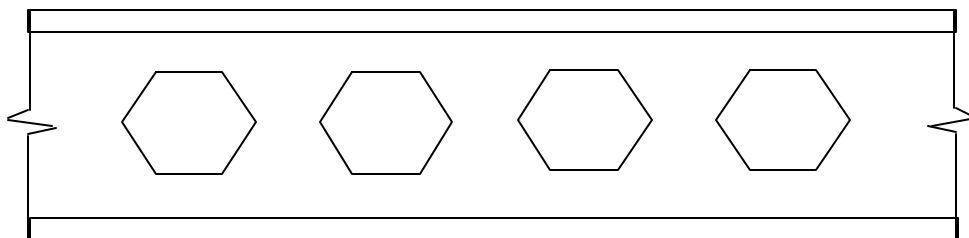

(e) Castellated beams

Fig.1 Common types of web openings

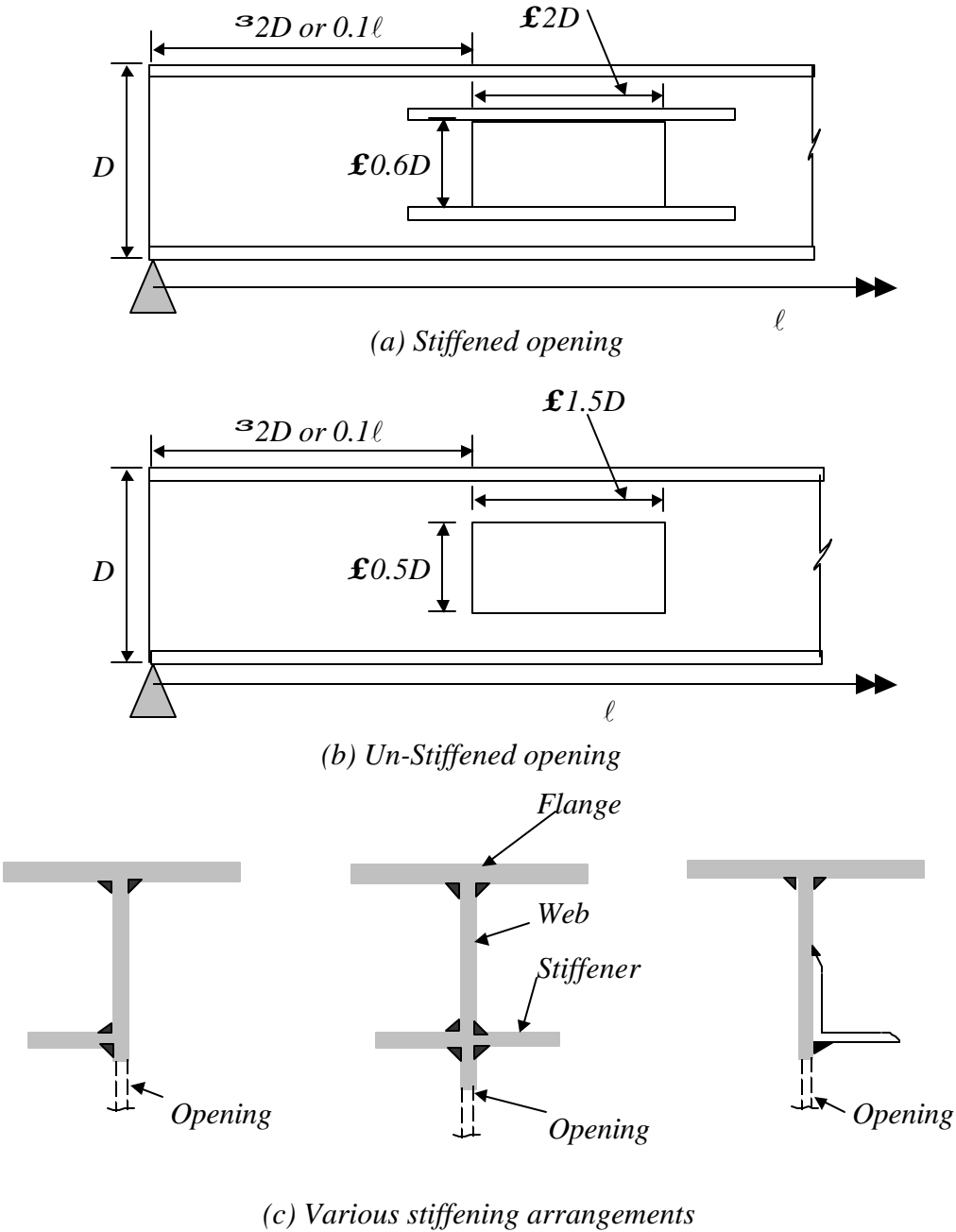

Fig. 2 Guide lines for web holes and various stiffening arrangements

- The hole should be centrally placed in the web and eccentricity of the opening is avoided as far as possible.
- Unstiffened openings are not always appropriate, unless they are located in low shear and low bending moment regions.
- Web opening should be away from the support by at least twice the beam depth, D or 10% of the span (ℓ), whichever is greater
- The best location for the opening is within the middle third of the span.
- Clear Spacing between the openings should not be less than beam depth, D .

- The best location for opening is where the shear force is the lowest.
- The diameter of circular openings is generally restricted to $0.5D$.
- Depth of rectangular openings should not be greater than $0.5D$ and the length not greater than $1.5D$ for un-stiffened openings. The clear spacing between such opening should be at least equal the longer dimension of the opening.
- The depth of the rectangular openings should not be greater than $0.6D$ and the length not greater than $2D$ for stiffened openings. The above rule regarding spacing applies.
- Corners of rectangular openings should be rounded
- Point loads should not be applied at less than D from side of the adjacent opening.
- If stiffeners are provided at the openings, the length of the welds should be sufficient to develop the full strength of the stiffener. Various types of stiffeners are shown in Fig. 2(c).
- If the above rules are followed, the additional deflection due to each opening may be taken as 3% of the mid-span deflection of the beam without the opening.

3.0 FORCE DISTRIBUTION AND FAILURE PATTERN AT WEB OPENINGS

3.1 Beams with perforated thick webs

In buildings, the depth to thickness ratio of the beam web is kept low (below 80). Such webs are not prone to local buckling in shear and are termed “thick webs”. On the other hand, in bridge structures the girder depths adopted are generally large and hence the plate girders are characterised by web slenderness ratios above 80. The behaviour of these plate girders has been elaborately discussed by Narayanan ⁽⁴⁾ and is not discussed here. However in building floor construction, stockier webs having slenderness ratio of 50 to 80 are more common and the discussion in the section is restricted to such beams with openings. Mathematical models for the design of thick webs containing openings have been developed by Redwood and his colleagues based on the plastic analysis of structures and is described below.

3.2 Basis of Analysis

A single rectangular opening in a traditional beam used in buildings is considered first [See Fig. 3(a)]. The hole is located a little bit above the Neutral axis for illustration. The hole may (or may not) be reinforced.

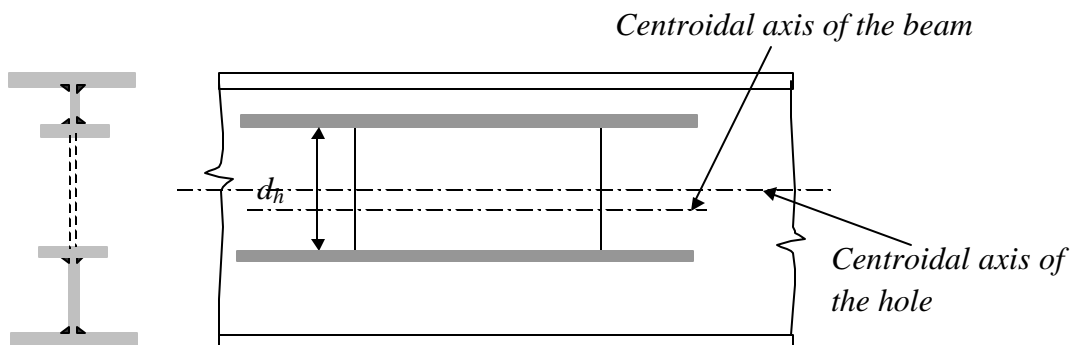

Fig. 3(a) Rectangular Hole in the web

The web of the beam is “thick” and is not prone to buckling in shear under the action of the loads, the collapse is likely to be initiated by the formation of four plastic hinges, near the four corners of the hole in the web above and below the openings. Note the location of four plastic hinges in Fig. 3(b). This is due to behaviour of the beam as a viereendeel girder.

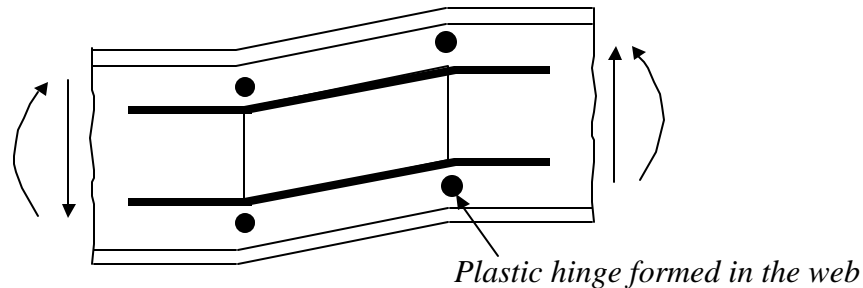

Fig. 3(b) Mode of failure

3.2.1 Force distribution and failure pattern

The forces acting at the ends of a rectangular opening are shown in the Fig. 4(a). For thick webs with a circular opening, Redwood proposed an equivalent effective size of rectangular opening as shown in Fig. 4(b). Note that R represents the radius of circular opening in Fig. 4(b). It is seen that the overall bending moment M is resisted by the compression T_2 in the top web plate, and tension T_1 in the bottom web plate forming a couple ($T_1 = T_2$ for equilibrium) acting at distance h apart, together with relatively small moments M_{t1} and M_{b1} acting in the top and bottom portions of the opening. These moments M_{t1} and M_{b1} are generated because of viereendeel action and hence called viereendeel moments. At the opening adjacent to lower moment section the shear V will be resisted by V_t shear in the web plate above the hole (“top web plate”) and V_b shear in the web plate below the hole (“bottom web plate”). For equilibrium the following conditions have to be satisfied:

$$V = V_t + V_b$$

$$\text{and } M = (T_1 \text{ or } T_2) * h + M_{t1} + M_{b1}$$

Inelastic shearing deformation in the web at the opening occurs under any combination of moment and shearing force. This shearing deformation is called as ‘Viereendeel’ deformation. This shearing deformation and the plastic hinge rotations near the corners of the opening at ultimate load, lead to a large relative deflection between ends of the opening.

At failure, all elements (i.e. the top flange, bottom flange and the web plates above and below openings) are subjected to high combined stresses caused by axial force and shear force from overall bending and local moments due to viereendeel action. The bottom web plate is likely to yield due to tension and top web plate above opening is susceptible to

buckling/ yielding. The deformed shape of the beam caused by the moment and shear acting across the opening is shown in Fig. 4(c).

The Vierendeel moment across the opening is resisted by the plastic moment capacities of the sections. It is assumed that the upper and lower web sections resist the applied shear in proportion to square of their depths. Plastic moment capacities of the sections are reduced in the presence of this shear force and axial force.

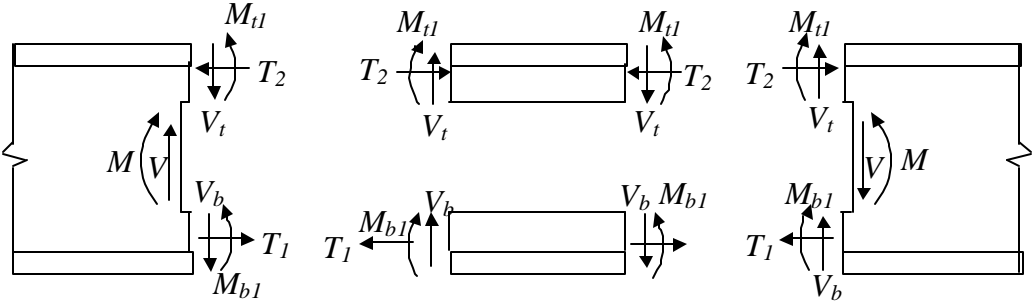

(a) Force distribution in steel beam at opening

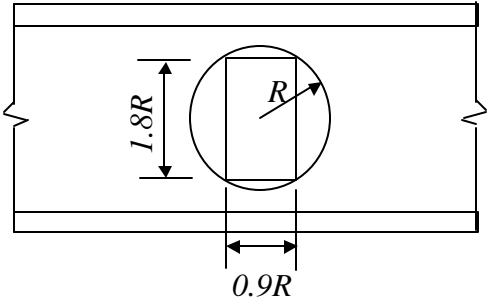

(b) Effective size of circular hole in the web

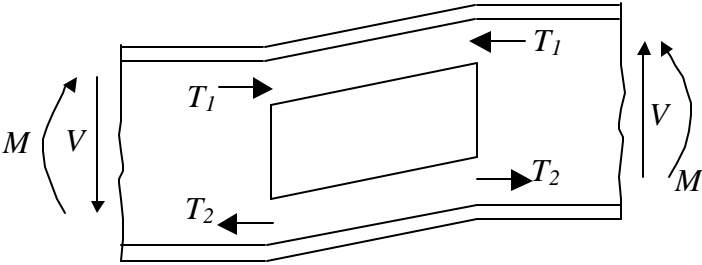

(c) A typical failure pattern

Fig. 4 Behaviour of steel beams with web holes

3.2.2 Web instability for beams with “thick” webs

The ultimate strength of the beam with a “thick web” is determined by plastic analysis without considering the effect of web buckling. This procedure is valid if effective depth of the web is limited to outstand proportion of compact sections i.e. $d_{te} \leq 10t$ as plastic and compact sections are not vulnerable to local web buckling. Outstand proportions of the T-sections are given in Table 1.

Table 1 – Outstand proportions for T- sections

Type of element	Class of section		
	Plastic	Compact	Semi-compact
Stems of T-sections	$d_{te}/t \leq 8.9$	$d_{te}/t \leq 10$	$d_{te}/t \leq 20$
Where, d_{te} – Effective depth of the T-sections t – thickness of the T-sections { EMBED Equation.3 } and f_y - yield stress of the steel			

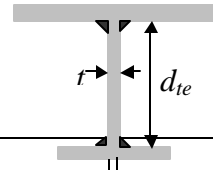

Fig. 5 shows instability of web near opening in an un-stiffened girder, when the web is supported only on three sides as in T sections. By considering the variation of stress from compression to tension along the upper edge of the opening, the effective support of the flange and the continuity provided by the web adjacent to the opening, the effective depth of the web can be calculated using the equation given below:

$$d_{te} = \frac{d_t}{\sqrt{1 + \left(\frac{2d_t}{ka_n}\right)^2}} \tag{1}$$

where, k - reflects the combined influence of the shape of the local bending moment diagram along the upper web-flange section, and the effect of continuity (See Table 2).

d_t - Web depth above the opening.

Table 2 – Values of k

Condition	Value of k
The ratio of web stresses at either end of the opening is less than -0.5	0.5
The web opening is in uniform compression over its length	1.0

However, when the edges of the openings are un-stiffened, the semi-compact or slender sections are susceptible to local buckling of the web-flange section (T section) at the horizontal edge that is in compression due to the global bending action. The opening in such cases may be stiffened or only the elastic capacity of the web-flange section may be used. It is necessary to check for the compression zone stability of the large rectangular openings in high moment regions. This is carried out by treating it as an axially loaded column with effective length equal to that of the length of the opening. For unstiffened

openings, this check is not necessary if the opening length is less than four times the depth of the T section under compression. Normally, instability of the vertical sides of the web opening will not occur in rolled sections except in high shear zones. But, fabricated beams are more susceptible to this form of the web instability.

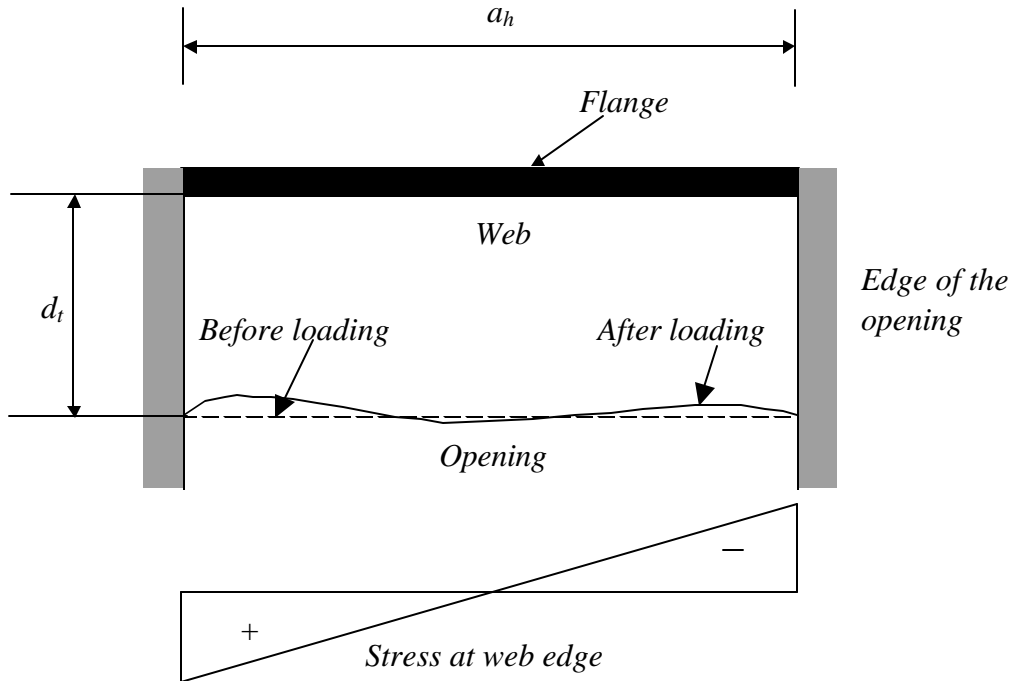

Fig. 5 Local buckling of un-stiffened web

3.2.3 Lateral torsional stability⁽²⁾

It is necessary to check for adequacy of the beam against lateral torsional buckling because the resistance at the opening should not govern the beam resistance. In this case while checking the stability, the effect of the opening is incorporated by multiplying the St. Venant's torsion constant, J , by

$$\left[1 - \left(\frac{a_h}{\ell_u} \right) \left(\frac{d_h t - 2A_r}{t(D + 2B)} \right) \right]^2 \leq 1.0 \tag{1(a)}$$

- where, ℓ_u - Unbraced length of the compression flange
- a_h - Length of the opening
- d_h - Depth of the opening
- D - Overall depth of steel beam
- B - Breadth of the flange of steel beam
- t - Thickness of the web of the steel beam
- A_r - Area of reinforcement provided at the opening

3.3 Analysis of beams with perforated thick webs

The unreinforced opening can be analysed reasonably well without using simplifying assumptions. From the point of view of economy, one may like to use unreinforced openings. If the reinforcement is required, the conservative assumptions made in the analysis of reinforced case increase the material requirement enormously. In addition, the cost is further increased due to welding. The analysis outlined here is conservative when compared with other more precise methods.

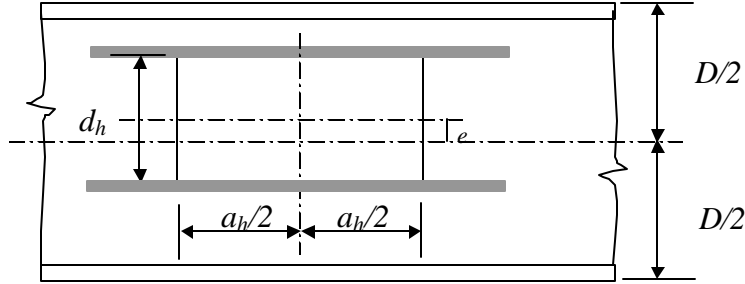

Fig. 6 Opening in beam with thick web

Fig. 6 shows an opening in a beam with a relatively thick web. The figure shows a web opening of length a_h and depth d_h . The opening is located at an eccentricity e with respect to centre line of the beam. The strength of the beam at the opening can be represented by a moment – shear interaction diagram as shown in Fig. 7. It may be noted that the shear capacity V_B of the section with opening is constant upto a factored moment of M_B . As the moment increases beyond M_B , the shear capacity would reduce because the compression due to moment and that due to shear make the compression diagonal to buckle. When the maximum moment capacity M_A is reached, the shear capacity becomes zero. For moments above M_B but less than M_A , shear capacity V may be obtained using the following non-linear interaction equation.

$$(V/V_B)^2 + [(M - M_B)/(M_A - M_B)]^2 = 1.0$$

Conservatively, sometimes designers prefer to use a linear equation between the limits M_B and M_A . The shear capacity at M_B is V_B and the shear capacity at M_A is zero. This is shown by the dotted lines in the interaction diagram. If a beam is to be safe, the moment (M_f) and the shear (V_f) due to factored loading on the beam should be less than corresponding beam resistance given by moment-shear interaction curve. The factored shear V_f and moment M_f should be such that

$$V_f \leq V_B \tag{2}$$

$$M_f \leq M_A - [M_A - M_B] V_f / V_B \tag{3}$$

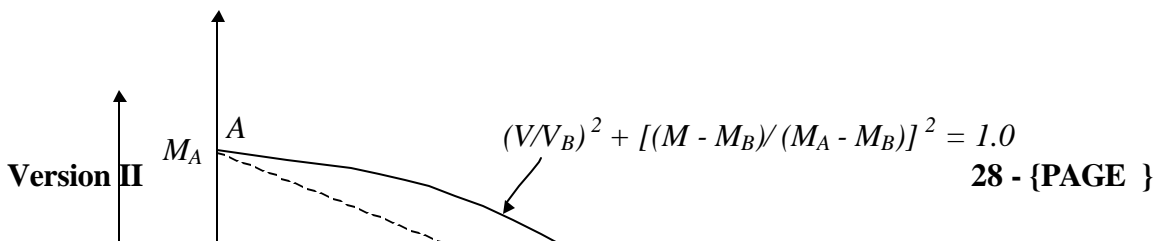

3.4 Unreinforced openings in beams with “thick” webs

Let us first examine the case of an unstiffened web opening. Redwood and his colleagues have proposed the following equations for evaluating M_A and M_B based on the plastic analysis described above. Due to the interaction of shear and moment, the capacity of the section gets reduced. The reduction in capacities (either moment or shear) at salient levels (i.e. at M_A , M_B and V_B) is expressed as a ratio of their plastic moment / plastic shear capacities as follows:

In the case of un-stiffened web openings, the salient points of the shear and moment interaction diagram (Fig. 7) can be written as:

$$\frac{M_A}{M_P} = 1 - \frac{\left\{ \frac{A_w}{4A_f} \left[\left(\frac{d_h}{D} \right)^2 + \left(\frac{4e}{D} \right) \left(\frac{d_h}{D} \right) \right] \right\}}{1 + \frac{A_w}{4A_f}} \quad (4)$$

$$\frac{M_B}{M_P} = \frac{\left[1 - \frac{1}{\sqrt{3}} \left[\frac{A_w}{A_f} \right] \left[\frac{a_h}{D} \right] \sqrt{\frac{\mathbf{a}_2}{1 + \mathbf{a}_2}} \right]}{\frac{1 + \frac{A_w}{4A_f}}{\sqrt{1 + \mathbf{a}_1}}} \quad (5)$$

$$\frac{V_B}{V_P} = \frac{1}{\sqrt{3}} \left[\frac{a_h}{D} \right] \left[\frac{1 + \frac{A_w}{4A_f}}{\sqrt{1 + \mathbf{a}_1}} - \frac{\mathbf{a}_2}{\sqrt{1 + \mathbf{a}_2}} \right] \quad (6)$$

$$\mathbf{a}_1 = \frac{3}{4} \left[\frac{D}{a_h} \right]^2 \left[1 - \frac{d_h}{D} - \frac{2e}{D} \right]^2 \quad (7)$$

$$\mathbf{a}_2 = \frac{3}{4} \left[\frac{D}{a_h} \right]^2 \left[1 - \frac{d_h}{D} + \frac{2e}{D} \right]^2 \quad (8)$$

where, M_p - Plastic moment capacity of the unperforated beam section.
 V_p - Plastic shearing capacity of the unperforated beam section.
 e - Eccentricity of opening and is taken as positive, whether the opening lies above or below the beam centre line.
 A_f, A_w - Area of one flange and area of web of the steel beam section respectively
 M_f, V_f - Factored moment and factored shear at opening centre line respectively.
 D - Total depth of beam
 a_h - Length of opening
 d_h - Total depth of opening

The detailed derivation of the above equation may be followed from original source. ⁽²⁾

3.5 Reinforced openings

If the opening is reinforced as shown in Fig. 6, then the eqs. (9) and (10) must be satisfied along with equations (2) and (3). In no case area of reinforcing bars A_r , should be greater than the area of one flange of steel beam section, to prevent inadvertent flange instability.

$$V_f \leq V_p \left(1 - \frac{d_h}{D} \right) \quad (9)$$

$$M_f \leq M_p \quad (10)$$

In this case the salient points of the interaction diagram (Fig. 7) are defined by

$$\left[\frac{M_A}{M_p} \right]_a = I + \frac{\left[\frac{A_r}{A_f} \left[\frac{d_h}{D} \right] - \frac{A_w}{4A_f} \left[\left[\frac{d_h}{D} \right]^2 + 4 \left[\frac{d_h}{D} \right] \left[\frac{e}{D} \right] - 4 \left[\frac{e}{D} \right]^2 \right] \right]}{\left[I + \frac{A_w}{4A_f} \right]} \quad \text{for } \frac{e}{D} \leq \frac{A_r}{A_w} \quad (11)$$

$$\left[\frac{M_A}{M_p} \right]_b = \frac{\left[\frac{M_A}{M_p} \right]_a - \frac{A_w}{A_f} \left[\frac{e}{D} - \frac{A_r}{A_w} \right]^2}{\left[I + \frac{A_w}{4A_f} \right]} \quad \text{for } \frac{e}{D} > \frac{A_r}{A_w} \quad (12)$$

$$\frac{M_B}{M_p} = \frac{1 - \frac{A_r}{A_f}}{1 + \frac{A_w}{4A_f}} \quad (13)$$

$$\frac{V_B}{V_p} = 2\sqrt{3} \left(\frac{D}{a_h} \right) \left[\frac{A_r}{A_w} \right] \left[1 - \frac{d_h}{D} \right] \quad (14)$$

Substituting the values of M_A , M_B and V_B from eqs. (11) or (12), (13) and (14) into eqs. (2) and (3) leads to a quadratic equation. The solution of this quadratic equation gives the area of reinforcement required at the opening. This procedure can be used as a basis for design aids giving directly the required reinforcement area for a given loading.

4.0 Plate girders with openings in the web

Typical slenderness values for these webs lie in the range of 150 to 250 and they invariably buckle prior to the actual collapse of girder. The following analysis is valid for plate girders in the practical range having depth to stiffener spacing greater than 1.

The following is the summary of experimental studies ⁽⁴⁾:

- In statically loaded plate girders containing circular and rectangular openings the girders having openings in the high shear zone failed at loads significantly lower than those that had openings in high moment zones.
- In case of circular openings, the ultimate shear capacity of webs dropped almost linearly with the increase in the diameter of the opening.
- The observed failure mechanism for plate girders with web openings is similar to that of plate girders with un-perforated webs discussed in the chapter on Plate girders - I, the only difference is in the position of hinges in the flanges under the action of diagonal tension field in the web.

Fig. 8(a) shows the position of hinges at the instant of failure in a plate girder when diameter of the web opening is nearly equal to the depth of the girder. In this case the internal two hinges are formed at the centre of flanges. Fig. 8(b), 8(c) shows the position of hinges (A, B, C, D) at the instant of failure in a plate girder with centrally placed small circular or rectangular openings. The internal plastic hinges (B, C) will form at the position of maximum bending moment, where the shear force is zero.

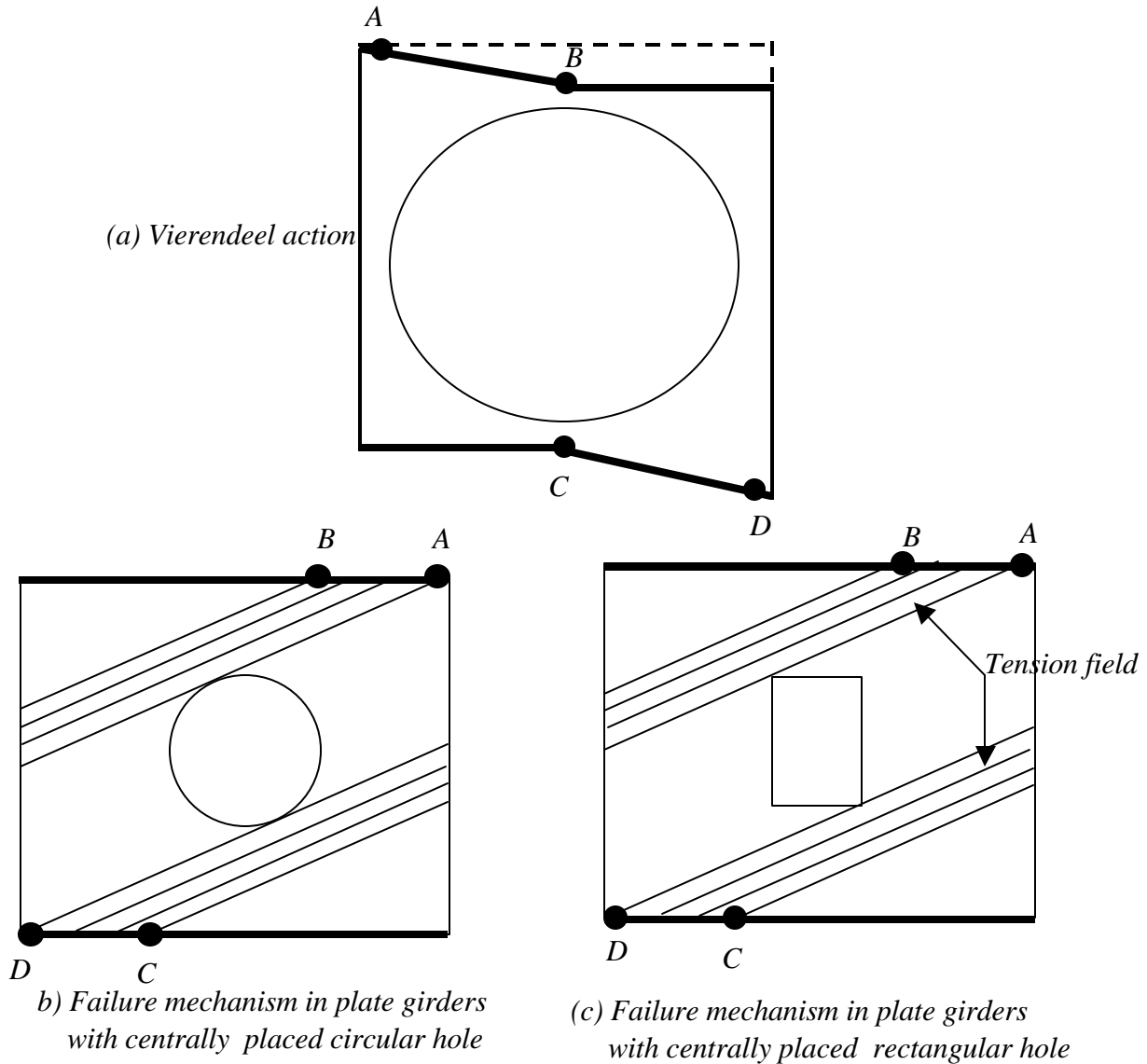

Fig. 8 Plate girders with web holes

4.1 Analysis of Plate girders with web openings

The method adopted for evaluation of ultimate shear capacity of plate girders with web openings is similar to the method discussed in the chapter titled Plate Girders – I for unperforated plate girders. Ultimate shear capacity can be obtained as the sum of following four contributions:

- i. The reduced value of elastic critical load in the perforated web
- ii. The load carried by the membrane tension in the post critical stage
- iii. The load carried by the flanges

- iv. The load carried by the reinforcement, if any

Elastic critical load of the web and load carried by membrane tension in the web are the two contributions affected by introduction of openings in the webs. The introduction of openings in the web decreases buckling resistance and hence elastic critical load is reduced. The amount of reduction actually depends upon the ratio of opening size to the width of the plate. Thus reduced buckling coefficient should be used in calculating elastic critical stress. The tension field in un-perforated web is developed predominantly along the diagonal band. Placement of web openings in this zone reduces the width of the Tension field and so causes significant drop in strength of the girder.

4.2 Approximate method

This section explains an approximate method to assess the ultimate capacity of a plate girder with the circular web opening without reinforcement. The method consists of linearly interpolating between the value of V_S for an unperforated web obtained from equation (6) of the- chapter on Plate girders-I and the Vierendeel load, V_V obtained as described below. The symbols used in the following equations are the same as in chapter on Plate girders -I unless otherwise specified.

If the diameter of the opening, D_h , covers the full depth, d , of the girder, the failure would be essentially due to Vierendeel mechanism as shown in Fig. 8(a). The corresponding collapse load, V_V , is given by

$$V_V = \frac{8M_p}{a} \quad (15)$$

where a is clear width of web plate between vertical stiffeners

Thus, for an opening diameter smaller than D_h , the ultimate shear capacity (V_{ult}) can be approximated by linear interpolation between the values of V_V and V_S .

$$V_{ult} = V_V + \left(\frac{V_S - V_V}{d} \right) (d - D_h) \quad (16)$$

where, d - depth of the web for the plate girder

4.3 Plate girder webs with unreinforced circular openings

The reduced value of elastic critical stress $[(q_{cr})_{red}]$ due to web openings can be determined from classical stability theory if the boundary conditions of the web plate are known. In calculating $(q_{cr})_{red}$, the value of 'k' appropriate to a web fixed at its edges should be used. The reason for this is the relative stiffness of the flange in comparison with the web increases significantly when the opening is introduced in the web and the behaviour of the web plate will be closer to one having fixed supports at the flange web junction.

The critical shear stress for case without opening is given by

$$(q_{cr}) = k_s \frac{p^2 E}{12(1-n^2)} \left(\frac{t}{d}\right)^2 \quad (17)$$

However the effect of opening can be considered if reduced shear buckling co-efficient k is used in place of k_s , where

$$k = k_s \left(1 - \frac{D_h}{d}\right) \quad (18a)$$

The shear buckling stress $(q_{cr})_{red}$ is thus obtained.

k_s is the shear buckling coefficient. For fixed edges, k_s is evaluated from

$$k_s = 8.98 + 5.6 \left(\frac{d}{a}\right)^2 \quad \text{where } \frac{a}{d} \geq 1, \text{ i.e. for wide panels} \quad (18b)$$

$$k_s = 8.98 \left(\frac{d}{a}\right)^2 + 5.6 \quad \text{where } \frac{a}{d} \leq 1, \text{ i.e. for webs with closely spaced transverse stiffeners} \quad (18c)$$

By using the virtual work method, the failure load can be computed from

$$V_{ult} = (q_{cr})_{red} \cdot d \cdot t + p_{yt} \cdot t \sin^2 \mathbf{q} (d \cot \mathbf{q} - a + c - D_h \operatorname{Cosec} \mathbf{q}) + 4 \frac{M_{pf}}{c} \quad (19)$$

where, a is clear width of web plate between vertical stiffeners,
 c is distance between the hinges given by:

$$c = \frac{2}{\sin \mathbf{q}} \sqrt{\frac{M_{pf}}{p_{yt} \cdot t}} \quad (20)$$

Tensile membrane stress, p_{yt} can be calculated from the following equation,

$$\frac{p_{yt}}{p_{yw}} = \sqrt{\left(1 - \frac{(q_{cr})_{red}}{q_{yw}}\right)^2 \left(1 - \frac{3}{4} \sin^2 2\mathbf{q}\right) - \frac{\sqrt{3}}{2} \cdot \frac{(q_{cr})_{red}}{q_{yw}} \sin 2\mathbf{q}} \quad (21)$$

By a systematic set of parametric studies, Evans has established that \mathbf{q} is approximately equal to $2/3$ of the inclination of diagonal of the web.

$$\mathbf{q} \cong \frac{2}{3} \tan^{-1} \left(\frac{d}{a}\right) \quad (22)$$

Notice that equation (19) is obtained by adding three quantities, namely web-buckling strength, post-buckling membrane strength of the web plate and the plastic moment capacity of the flange. This equation is valid only for openings having $[D_h \leq d \cos \mathbf{q} - a \sin \mathbf{q}]$. This limitation is not highly restrictive as it includes openings of all practical proportions.

In this context, it must be noted that in order for the flanges to develop hinges without buckling locally under compression due to overall bending, the section used should be a "*plastic*" one. If flanges can not develop plastic hinges because they are compact, semi-compact or slender, this method of analysis is NOT applicable.

4.4 Plate girder webs with unreinforced rectangular openings⁽⁴⁾

Based on the research done by Narayanan and Der Avanessian on plate girders with rectangular and square openings, the reduced elastic critical shear stress can be evaluated by the following formula,

$$(q_{cr})_{red} = \frac{k_s \mathbf{p}^2 E}{12(1-\nu^2)} \left(\frac{t}{d}\right)^2 \left[1 - \mathbf{a}_r \sqrt{\frac{A_o}{A}}\right] \quad (23)$$

where, A - Total area of the plate including the opening
 A_o - Area of the opening
 k_s - Coefficient for shear buckling stress given by equations (18b) and (18c)
 \mathbf{a}_r - A coefficient, depending on the end conditions and has a value of 1.25 for clamped edges.

By using the virtual work method, the failure load can be computed from

$$V_{ult} = (q_{cr})_{red} \cdot d \cdot t + p_{yt} \cdot t \cdot \sin^2 \mathbf{e} (d \cot \mathbf{e} - a + c - \mathbf{a} \operatorname{Cosec} \mathbf{e}) + 4 \frac{M_{pf}}{c} \quad (24)$$

where, { EMBED Equation.3 }

a - Clear width of web plate between vertical stiffeners
 d_h - Depth of the opening
 a_h - Breadth of the opening
 \mathbf{a} - The angle of inclination of the diagonal of the opening, i.e., $\mathbf{a} = \tan^{-1} (d_h/a_h)$

Quantities p_{yt} , c and \mathbf{q} are evaluated from equations (20), (21) and (22), respectively. Eq. (24) covers all practical ranges of web openings and is valid for depths of openings given by $d_h < [d - (a + a_h) \tan \mathbf{q}]$.

5.0 SUMMARY

This chapter emphasises the need for openings in the webs of girders. Two types of beams and girders are covered (i) beams with thick webs where web buckling is not a

design criterion and (ii) plate girders with thin webs where web buckling is consideration. Various types of openings are discussed and guidelines are given wherever required for the convenience of designers. Failure phenomena are discussed and equations are given for the purpose of design. The method of analysis outlined in this chapter deals with the isolated openings such as those made for providing space for service ducts and other utilities. Analysis of castellated beams where openings occur at regular intervals and openings in the composite beam are not discussed in this chapter.

6.0 REFERENCES

1. Lawson. R.M, (1987): 'Design for openings in the webs of composite beams', CIRIA special publication 51, SCI publication 068.The Steel Construction Institute, Ascot.
2. Redwood. R. and Cho. S. H., (1993): 'Design of Steel and Composite beams with web openings', Journal of Constructional Steel Research, Volume 25, 23-41.
3. Redwood. R., (1983): 'Design of I-Beams with perforations', Beams and Beam Columns, Stability and Strength (Editor R. Narayanan), Applied Science publishers, London.
4. Narayanan. R., (1983): 'Ultimate shear capacity of Plate girders with openings in webs', Plated Structures, Stability and Strength Series, Elsevier Applied Science.