

9

LATERALLY RESTRAINED BEAMS

1.0 INTRODUCTION

Beams are structural members frequently used to carry loads that are transverse to their longitudinal axis. They transfer loads primarily by bending and shear. In a rectangular building frame, beams that span between adjacent columns are called '*main or primary beams/girders*'. Beams, which are used to transmit the floor loading to the main beams between columns, are called '*secondary beams/joists*'. As far as the structural steel framing in buildings is concerned, it is sufficient to consider only the bending effects for beams, as torsion is not generally predominant. For a beam (loaded predominantly by flexure) two essential requirements must be met to develop its full moment capacity:

1. The elements of the beam (i.e. flange and web) should not buckle locally and
2. The beam as a whole should not buckle laterally.

To ensure that the first condition is met, the cross sections of the flange and the web chosen must be "*plastic*" or "*compact*". (These definitions are explained in the chapter on 'Local buckling' and also in later part of this chapter). If the beam is required to have significant ductility, plastic sections must invariably be used. To avoid the lateral buckling referred to under the second condition, restraints are provided to the beam in the plane of the compression flange, hence such beams are called "*laterally restrained beams*". In many steel structures, especially in buildings, beams carry floor decks on top of them, and these floor decks provide restraint to the compression flange. In the absence of any such restraints, and in case the lateral buckling of beams is not accounted for in design, the designer has to provide adequate lateral supports to the compression flange. In this chapter we are concerned with laterally restrained beams, in other words beams which have adequate lateral support to the compression flange. Beams, which buckle laterally, are covered in the next chapter.

2.0 BEHAVIOUR OF STEEL BEAMS

Laterally stable steel beams can fail only by (a) flexure (b) shear or (c) bearing, assuming that local buckling of slender components does not occur. These three conditions are the criteria for Limit State of collapse for steel beams. Steel beams would also become unserviceable due to excessive deflection and this is classified as a limit state of serviceability. In the following sections, we review the fundamentals of these limit states.

2.1 Flexural behaviour of steel beams

It is important to recognise that only plastic sections can be used in "*plastic design of frames*", where *moment redistribution is required throughout the frame*. "*Plastic analysis*" of the cross section is confined to the assessment of the *behaviour of the cross section at the instant of collapse*. These two terms are not to be confused for each other.

© Copyright reserved

If a flexural member is progressively loaded, it deflects and the curvature of such bending varies along its length. Initially the beam is elastic throughout its length. Let us consider a small portion of the beam at a point A as shown in Fig.1 (a) where the radius of curvature is ρ . If we consider a small segment of the beam at A [Fig.1 (b)], then the variation of the strain across the depth of the member could be found out geometrically as

$$\epsilon = \frac{z}{\rho} \tag{1}$$

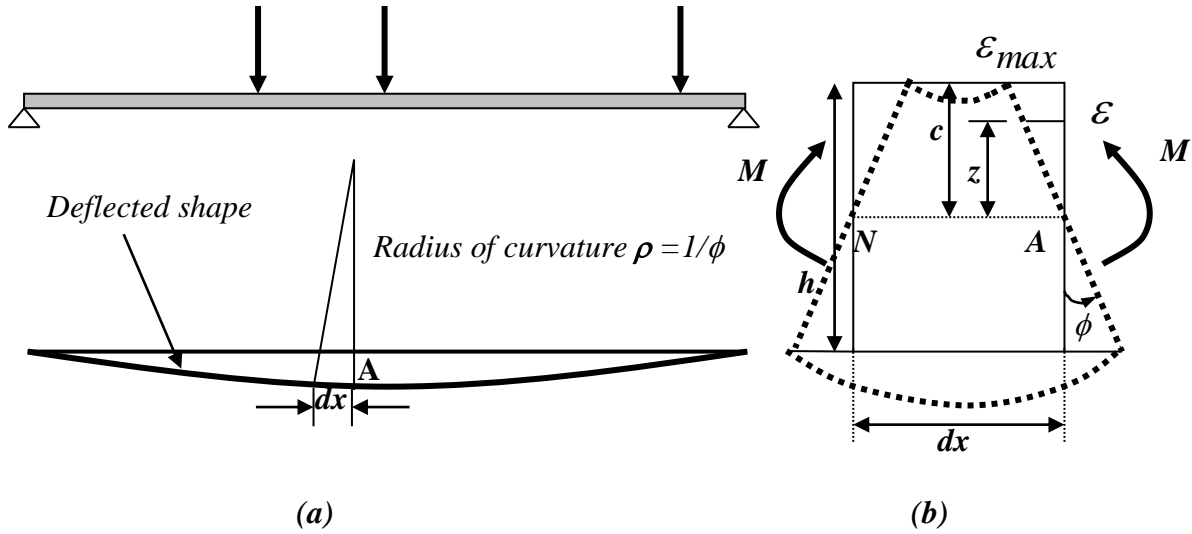

Fig.1 Curvature of bending

From Eq.1, the strain at any fibre is proportional to its distance ‘z’ from the neutral axis. This is obtained from the assumption that plane sections which are normal to the longitudinal axis before bending, remains plane and normal even after bending. For each

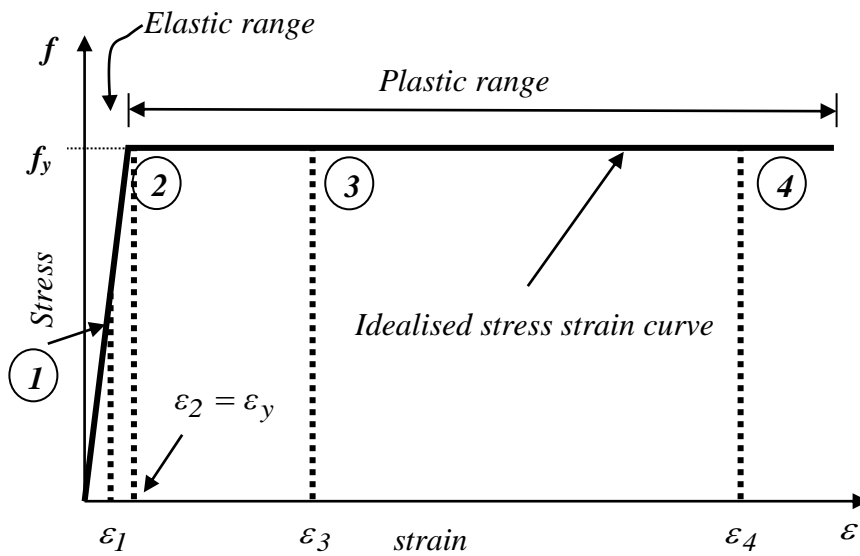

Fig.2 Idealised elasto- plastic stress- strain curve for steel

strain ' ϵ ' one can read off the corresponding stress ' f ' from the idealised stress-strain curve for steel shown in Fig. 2. (The idealised stress strain curve neglects the strain-hardening portion for all practical purposes). We choose four points 1, 2, 3, 4 on the stress-strain curve (Fig. 2) for further discussion and see how these four points are used when a simply supported beam is subjected to a mid point load.

2.2 Elastic flexural behaviour

Consider the point (1) in Fig.2 in which the strain $\epsilon_{max} = \epsilon_1$ which is less than the yield strain ϵ_y . At this stage, as seen from Figures 2 and 3, the stress is directly proportional to strain. Hence from elementary Strength of Materials, the corresponding moment of resistance (M_c) is given by

$$M_c = \frac{f_1 I}{c} \quad (2)$$

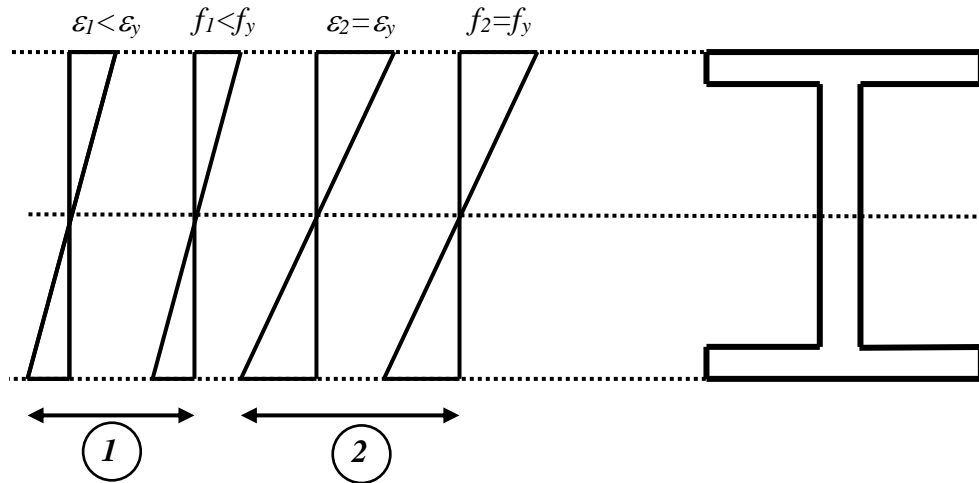

Fig.3 Strain and stress distributions in the elastic range

where ' f_1 ' is the extreme fibre stress, ' I ' is the moment of inertia and ' c ' is the extreme fibre distance from the neutral axis. The term $Z = I/c$ is the elastic section modulus which is a geometric property of the section. Hence Eq.2 can be rewritten in terms of elastic section modulus as

$$M_c = f_1 Z \quad (3)$$

2.3 Yield and plastic moment capacities

Now let us consider the point (2) in Fig. 2. The extreme fibre strain equals yield strain i.e. $\epsilon_{max} = \epsilon_2 = \epsilon_y$ and also the stress $f_2 = f_y$. where, f_y is the yield stress. Up to this stage, as shown in Fig. 3, the stress and strain are proportional to each other since the

extreme fibre of the beam is stressed within the elastic range. The corresponding moment, (M_y), is just sufficient to cause yield in the extreme fibres and is given by

$$M_y = f_y Z \tag{4}$$

where M_y is called the “*yield moment*”, i.e. the moment which just causes the extreme fibres to yield. It is evident from Fig. 5(b) that once the extreme fibre stresses attain yield stress they no longer take any additional stresses.

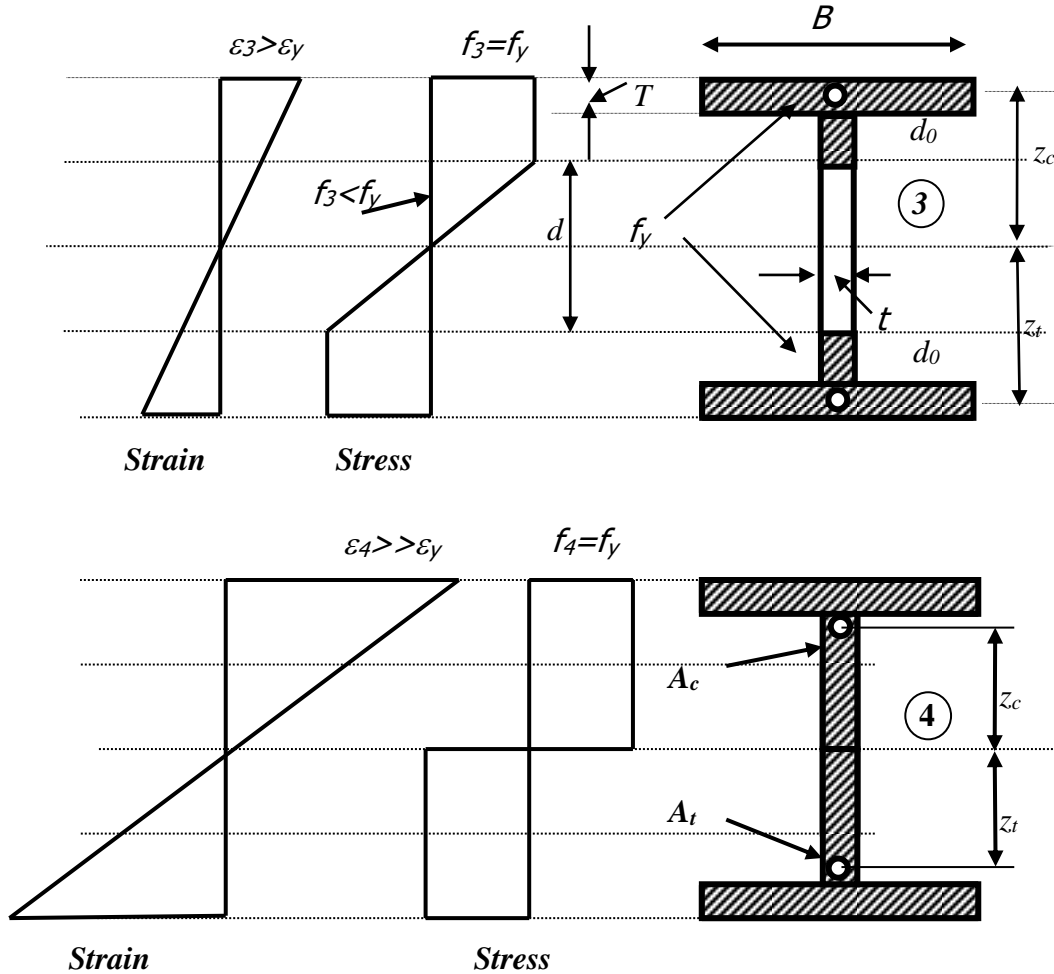

Fig. 4 Strain and stress distributions in plastic range

When the load and hence the moment is further increased, the outermost fibre strain ϵ_{max} near mid span of the beam (i.e. point of maximum bending moment) would attain a value say, $\epsilon_3 > \epsilon_y$ and this is identified as point (3) in Fig. 2. At this stage the strain is in the plastic stage, but extreme fibre stress still equals yield stress f_y . We also note that the stresses have been redistributed to the inner fibres towards the neutral axis and these fibres gradually attain a stress equal to f_y . This is shown in Fig.4. The remaining portion

of the beam in the vicinity of the neutral axis is still elastic. At this stage the moment capacity is calculated by considering both the plastic portion and the elastic core as,

$$M_c = \underbrace{f_y(BT + d_0t)(z_c + z_t)}_{\text{Plastic}} + \underbrace{\frac{f_y t d^2}{6}}_{\text{Elastic core}} \quad (5)$$

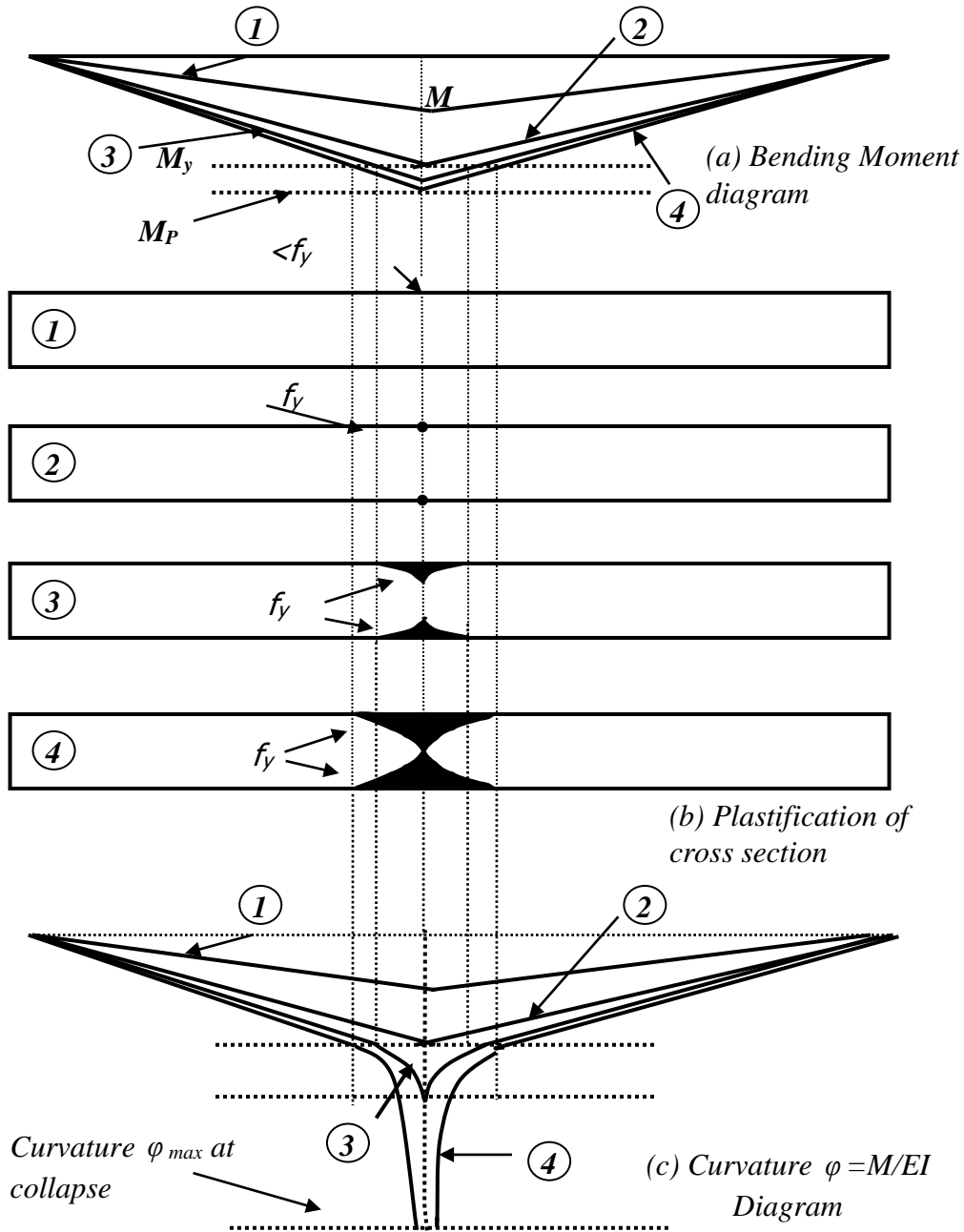

Fig.5 BM diagram and spread of plasticity across the thickness of the beam

Upon further loading, the outer fibre strain increases rapidly and attains a stage shown as point (4) in Fig.2. At this stage the elastic core in the immediate vicinity of the neutral axis becomes negligible due to the spread of plasticity into the fibres near the neutral axis. It is seen from Fig. 5(c) that the curvature ϕ of the beam (which was proportional to bending moment earlier) increases far more rapidly compared to the previous rate of increase, when the bending moment exceeds the yield moment value M_y . When the entire cross section of the beam gets fully plastified, the curvature become infinity as shown in Fig. 5(c). Fig.4 shows such a cross-section, which is fully plastified. This also is shown in Fig.5 where the two yield zones have merged at the neutral axis. When the entire beam cross section becomes plastic, it resists any further rotation under constant moment. At this stage the beam is said to have developed a '*plastic hinge*'. In view of this rotation, deflections become very large and the beam exhibits a kink at the plastic hinge as shown in Fig. 7. The magnitude of the bending moment, at which a plastic hinge is formed, is known as the '*plastic moment M_p* '. The moment- curvature relation of the cross section of the beam, at the point of maximum bending moment is shown in Fig. 6. The curvature increases enormously once the moment at the cross section reaches M_p . The value of M_p could be easily determined by taking moment of the total tension and compression areas about the plastic neutral axis as

$$M_p = Cz_c + Tz_t = f_y (A_c z_c + A_t z_t) = f_y \frac{A}{2} (z_c + z_t) \quad (6)$$

as shown in Fig.4, where A_c = area under compressive yield stress and A_t = area under tensile yield stress.

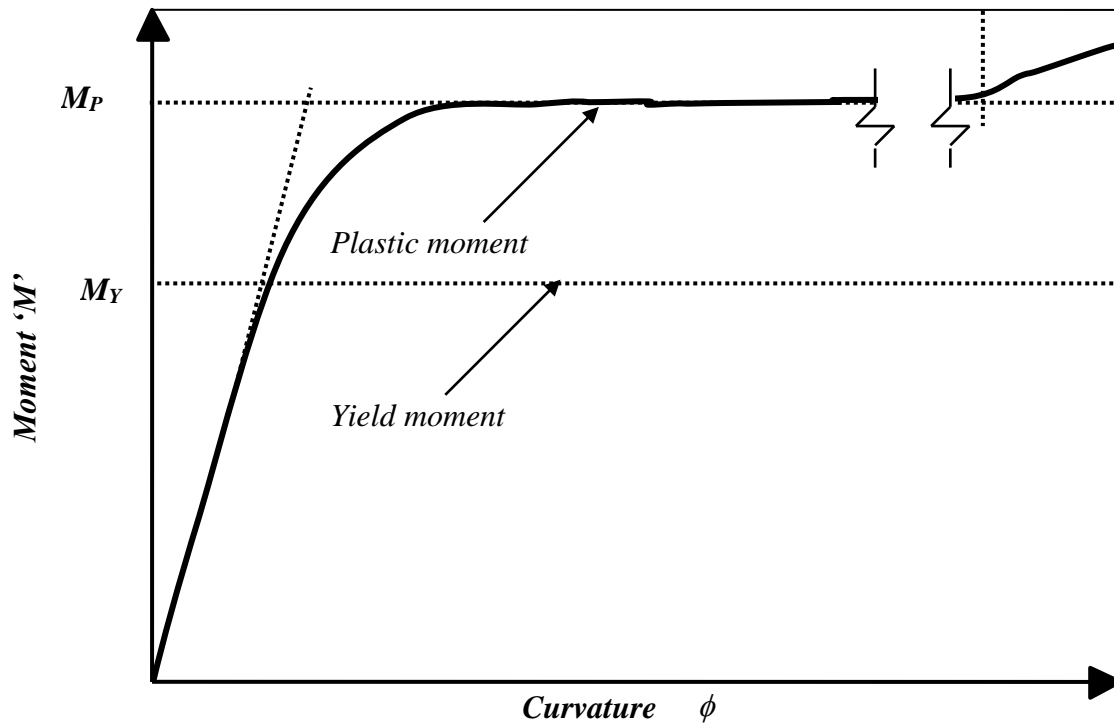

Fig. 6 Moment curvature characteristics of a simply supported beam

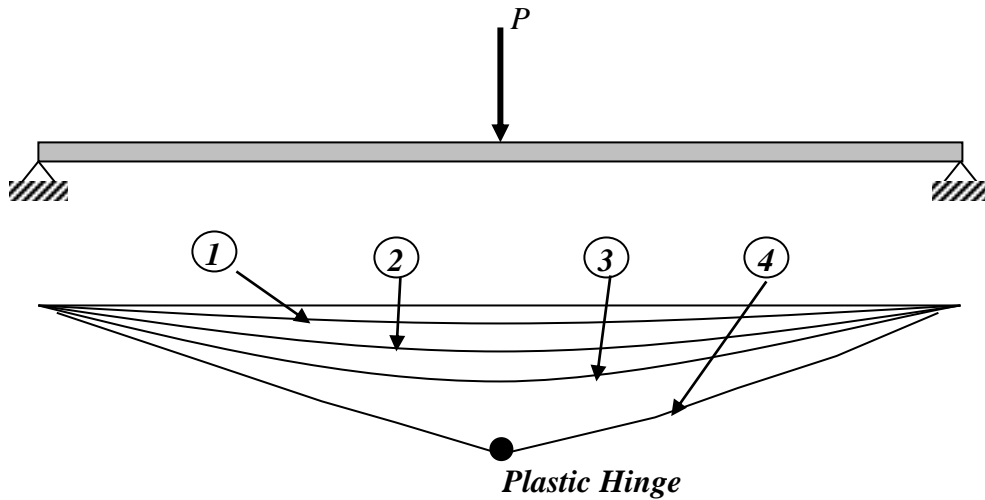

Fig.7 Simply supported beam and its deflection at various stages

In symmetrical sections the neutral axis coincides with the centroidal axis and this is not so in the case of unsymmetrical sections. However the plastic neutral axis for any cross section (also called as “*equal shear axis or equal area axis*”) could be located using the condition that the tension and compression areas must be equal as

$$A_c = A_t \quad (7)$$

From Eq.6 it is seen that the plastic section modulus (S) is given by

$$S = (A_c z_c + A_t z_t) \quad (8)$$

The value of S can be obtained as the sum of the moment of the cross sectional areas above and below the plastic neutral axis. The plastic moment capacity of the beam could be written as

$$M_p = f_y S \quad (9)$$

It is easily verified that for a rectangular section the ratio of the plastic to elastic section modulus called the ‘*shape factor*’ is 1.5. For I section the ratio varies between 1.07 to 1.20 and for most practical cases of I section this is taken as 1.12. This ratio also represents the ratio between the plastic moment to the yield moment. For example for an ‘ T ’ beam we can write

$$\frac{S}{Z} = 1.12 = \frac{M_p}{M_y} \quad (10)$$

where

This value 1.12 is derived as follows:

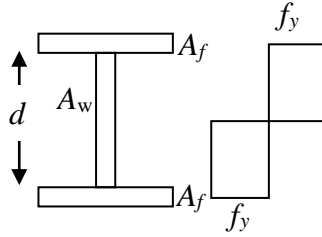

$$S = A_f f_y d (1 + A_w / 4A_f)$$

$$Z = A_f f_y d (1 + A_w / 6A_f)$$

$$S / Z = 1.04 \text{ for } A_f = A_w$$

$$S / Z = 1.12 \text{ for } A_f = 0.5A_w$$

3.0 SHEAR BEHAVIOUR OF STEEL BEAMS

Let us take the case of an ‘I’ beam subjected to the maximum shear force (at the support of a simply supported beam). The external shear ‘V’ varies along the longitudinal axis ‘x’ of the beam with bending moment as $V = \frac{dM}{dx}$. While the beam is in the elastic stage, the internal shear stresses τ which resist the external shear V can be written as,

$$\tau = \frac{VQ}{It} \tag{11}$$

where, V is the shear force at the section, I is the moment of inertia of the entire cross section about the neutral axis, Q is the moment about neutral axis of the area that is beyond the fibre at which τ is calculated and ‘t’ is the thickness of the portion at which τ is calculated.

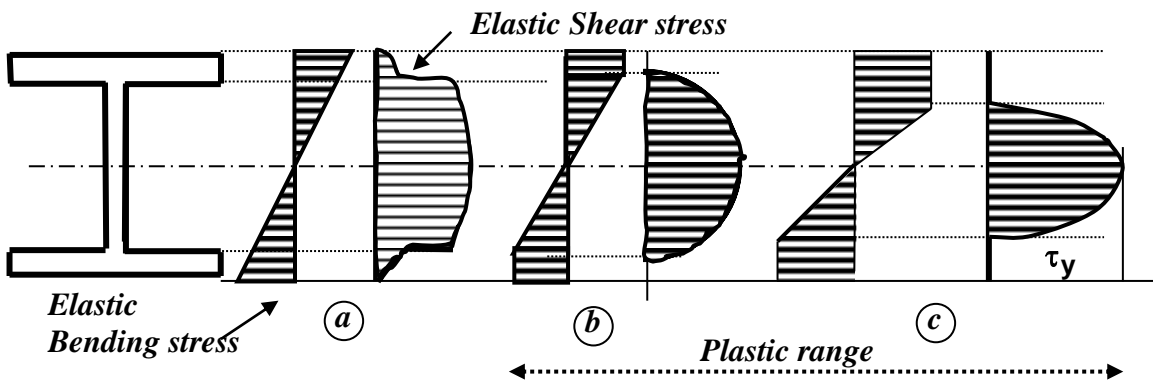

Fig. 8 Combined bending and shear in beams

Eq.11 is plotted in Fig. 8(a), which represents shear stresses in the elastic range. It is seen from Fig. 8(a) that a significant proportion of shear force is carried by the web and the

shear stress distribution over the web area is nearly uniform. Hence, for the purpose of design, we can assume without much error that the average shear stress as

$$\tau_{av} = \frac{V}{t_w d_w} \quad (12)$$

where, t_w is the thickness of the web and d_w is the depth of the web. The nominal shear yielding strength of webs is based on the von Mises yield criterion, which states that for an un-reinforced web of a beam, whose width to thickness ratio is comparatively small (so that web-buckling failure is avoided), the shear strength may be taken as

$$\tau_y = \frac{f_y}{\sqrt{3}} = 0.58 f_y \quad (13)$$

where f_y is the yield stress.

Using Eqns.12 and 13, the shear capacity of rolled beams V_c can be calculated as

$$V_c \approx 0.6 f_y t_w d_w \quad (14)$$

When the shear capacity of the beam is exceeded, the '*shear failure*' occurs by excessive shear yielding of the gross area of the webs as shown in Fig. 9. Shear yielding is very rare in rolled steel beams.

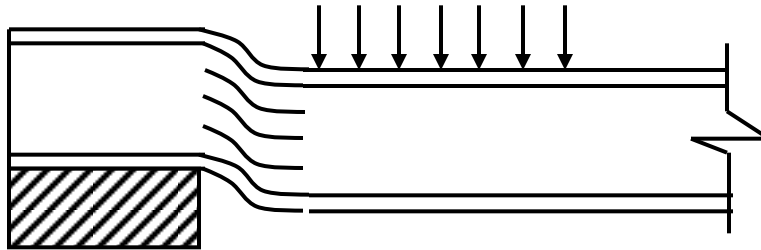

Fig.9 Shear yielding near support

4.0 WEB BUCKLING AND WEB CRIPPLING

The application of heavy concentrated loads produces a region of high compressive stresses in the web either at the support or under the load. This may cause either the web to buckle as shown in the Fig.10 (a) or the web to crumple as shown in Fig.10 (b). In the former case the web may be considered as a strut restrained by the beam flanges. Such '*idealised struts*' should be considered at the points of application of concentrated load or reactions at the supports as shown in Fig.11 and Fig.12.

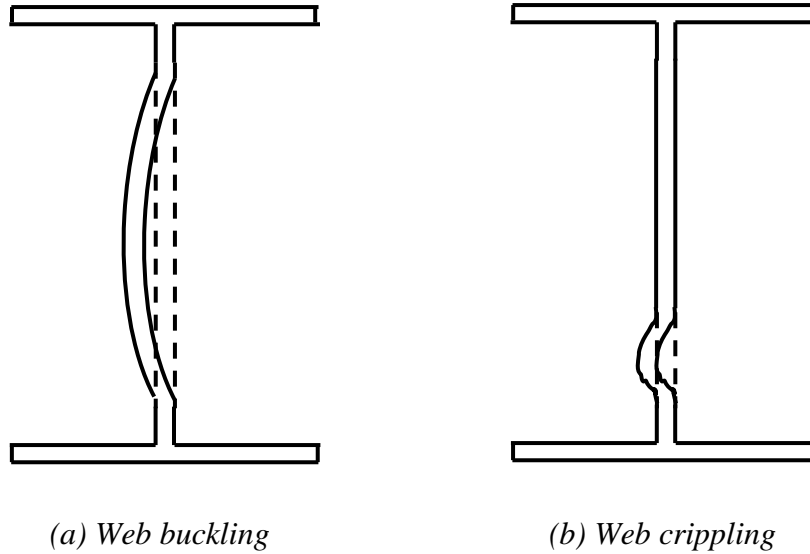

Fig.10 Local buckling of the web

In both the cases the load is spread out over a finite length of the web as shown in Fig.11. This is known as the '**dispersion length**' and its theoretical treatment is complex. Hence empirical formulae based on experiments are used. One such assumption is that the dispersion length is taken as $(b_l + n_l)$ where b_l is the stiff bearing length and n_l is the dispersion of 45° line at the mid depth of the section as shown in Fig.12. Hence the web buckling strength at the support is given by

$$P_{wb} = (b_l + n_l) t f_c \quad (15)$$

where ' t ' is the web thickness and f_c is the allowable compressive stress corresponding to the assumed "**web strut**". The effective length of the strut is taken as $L_E = 0.7d$ where ' d ' is the depth of the "**strut**" in between the flanges. The slenderness ratio of the idealised web strut could be written as

$$\lambda = \frac{L_E}{r_y} = \frac{0.7d}{r_y}$$

Since $r_y = \sqrt{\frac{I_y}{A}} = \sqrt{\frac{t^3}{12t}} = \frac{t}{2\sqrt{3}}$ (16)

$$\frac{L_E}{r_y} = 0.7d \frac{2\sqrt{3}}{t} \approx 2.5 \frac{d}{t}$$

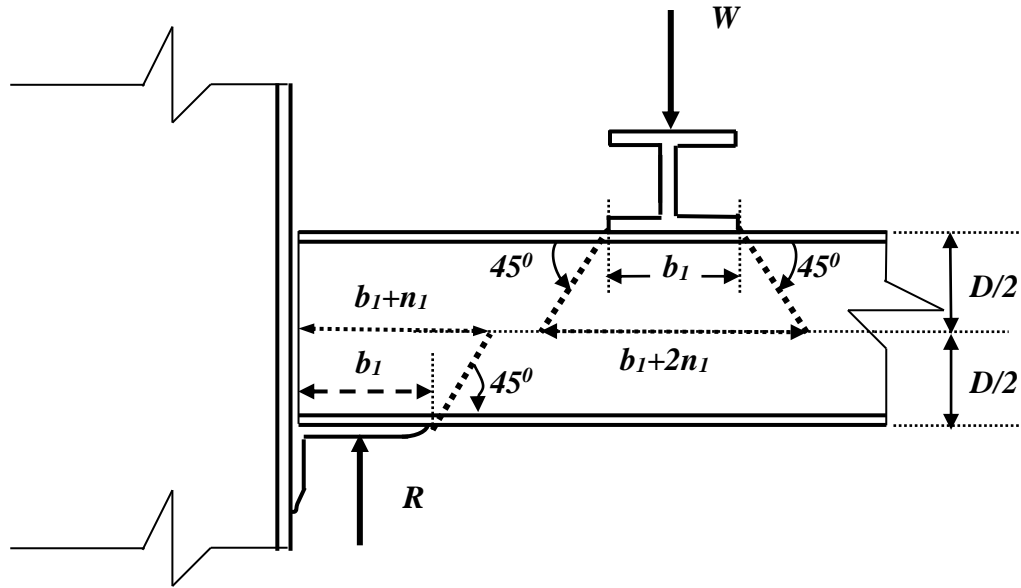

Fig.11 Dispersion of concentrated loads and reactions for evaluating web buckling

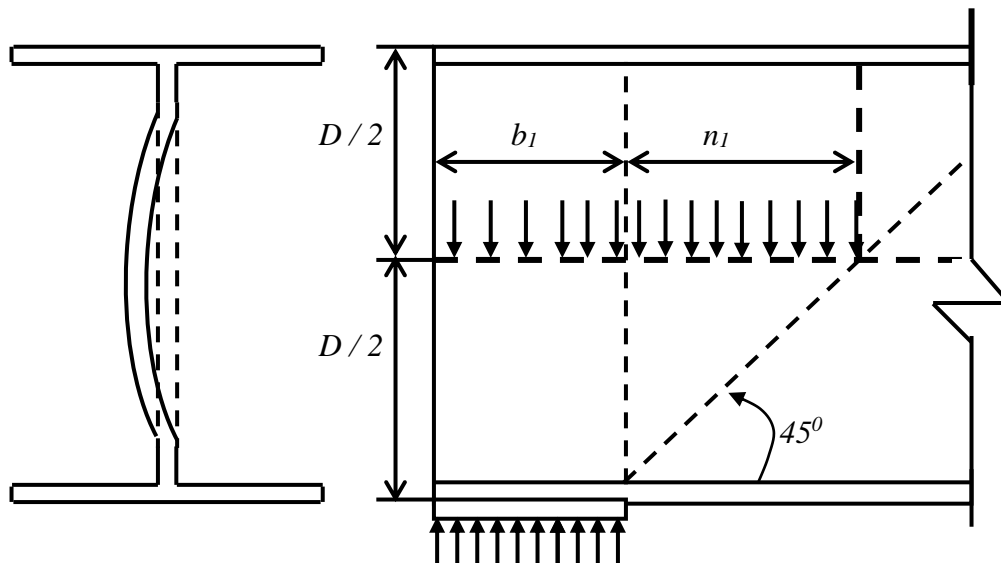

Fig. 12 Effective width for web buckling

Hence, the slenderness ratio of the idealised strut is taken as $\lambda = 2.5d / t$. Similarly the latter case of web crippling could also be calculated assuming a dispersion length of b_1+n_2 , where n_2 is the length obtained by dispersion through the flange, to the flange to web connection, at a slope of 1:2.5 to the plane of the flange (i.e. $n_2=1.5d$) as shown in Fig.13. As before, the crippling strength of the web at supports is calculated as

$$P_{crip} = (b_1 + n_2) t f_{yw} \tag{17}$$

where f_{yw} is the design yield strength of the web. At an interior point where concentrated load is acting, the crippling strength is given by,

$$P_{crip} = (b_1 + 2n_1) t f_{yw} \quad (18)$$

5.0 LIMIT STATE OF SERVICEABILITY – DEFLECTION

Although excessive vibration and excessive deflection are both classified as “limit state of serviceability”, the codes usually limit only the deflection. A beam designed to have adequate strength may become unsuitable if it cannot support its loads without excessive deflection. For example, excessive deflection in a floor not only gives a feeling of insecurity, but also damages the non-structural components (such as plaster) attached to it. Excessive deflections in industrial structures often cause misalignment of the supporting machinery and cause excessive vibration. Similarly high deflections in purlins may cause damage to the roofing material. Excessive deflection in the case of flat roof results in accumulation of water during rainstorms called “*ponding*”. There are instances reported in the literature where ponding had caused collapse of a flat roof. Hence the deflection in beams are restricted by codes of practice by specifying deflection limitations which are usually in terms of deflection to span ratio.

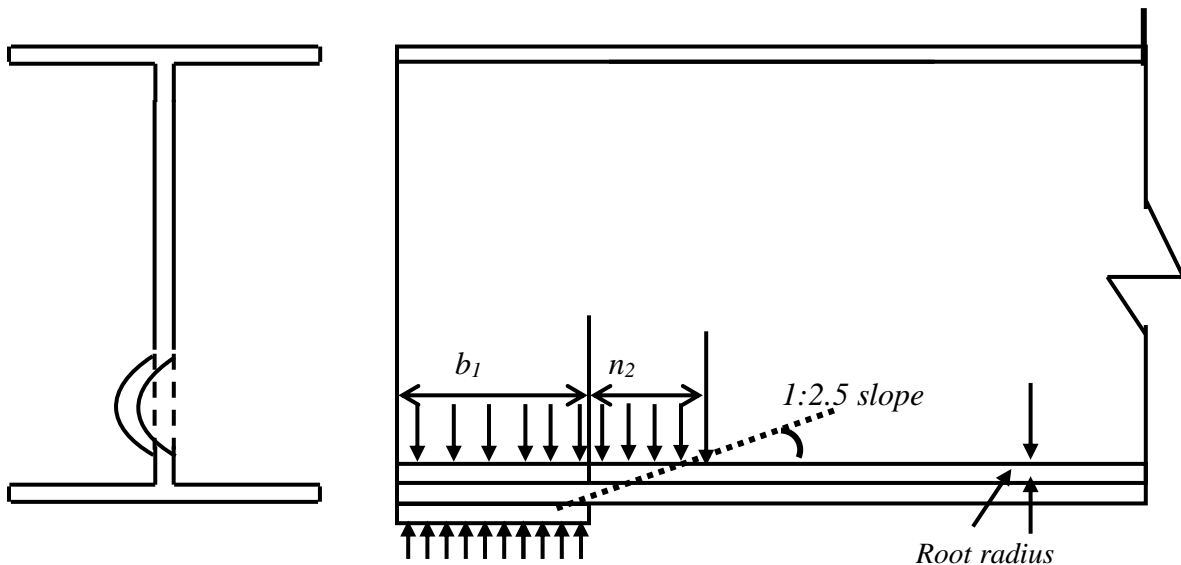

Fig. 13 Effective width of web bearing

In the case of beams (usually considered as simply supported), if the total load ‘ W ’, is assumed to be uniformly distributed, then the maximum deflection Δ is given by

$$\Delta = \frac{5}{384} \frac{WL^3}{EI} \quad (19)$$

where 'E', 'I' are the Young's modulus and moment of inertia of a beam of length 'L'. Since the maximum moment is $M = WL/8$ we may rewrite the Eq. (19) as

$$\Delta = \frac{5}{48} \frac{ML^2}{EI} \quad (20)$$

Substituting $\frac{M}{I} = \frac{f}{(d/2)}$ (where 'f' is the extreme fibre flexural stress) into Eq. (20)

we get

$$\Delta = \frac{5}{24} \frac{fL^2}{Ed} \quad (21)$$

Eq. (21) can be used with sufficient accuracy for all practical deflection calculations. Eq.(21) can also be rewritten in terms of L/d as

$$\frac{L}{d} = \frac{24}{5} \frac{E}{f} \frac{\Delta}{L} \quad (22)$$

The above equation represents the length/depth ratio of the beam corresponding a specific ratio of deflection to span. As stipulated by the codes of practice, if we restrict the deflection to (say) $\frac{\Delta}{L} = \frac{1}{325}$, using $f = 0.6 f_y$ (where f_y is the yield stress) we get the necessary $\frac{L}{d}$ ratio as

$$\frac{L}{d} = \frac{24}{5} \frac{2 \times 10^5}{0.6 f_y} \frac{1}{325} = \frac{4923}{f_y} \quad (23)$$

For an yield stress of $f_y = 250 \text{ MPa}$ in the above relation, (L/d) ratio works out to approximately 19. In other words, if a beam is chosen for design, whose (L/d) value is less than 19, then the deflection criteria would automatically be satisfied. Similarly for a simply supported beam subjected to central concentrated load, the (L/d) ratio can be shown to be 24. This (L/d) value is only a guiding parameter for satisfying the Limit state of serviceability and is not mandatory in design as long as check for serviceability is separately carried out.

6.0 LIMIT STATE DESIGN OF STEEL BEAMS

As we have outlined earlier, if the ultimate strength of the steel beams is to be mobilised, we must ensure that local buckling does not cause a premature failure. Hence in limit

state design of steel beams, we pay attention to local buckling using what is known as ‘*section classification*’.

6.1 Concept of section classification

The critical local buckling stress of the constituent plate element of a beam, for a given material and boundary conditions is ‘*inversely proportional to its breadth to thickness ratio*’. Hence by suitably reducing the slenderness of the plate elements, its resistance to local buckling could be enhanced. Once the local buckling is prevented, the beam can develop its full flexural moment capacity or the limit state in flexure. Hence depending upon the slenderness of the constituent plate element of the beam, they are classified as *slender, semi-compact, compact and plastic* as shown in Table 1. This section classification is new to the Indian structural designers who are familiar with the code of practice for structural steelwork in India, the IS: 800 (1984). Since IS: 800(1984) is based on ‘*Allowable Stress Method*’, the extreme fibre stress in the beams is restricted to $0.66f_y$. In addition, the ‘I’ sections rolled in India are found to be at least semi-compact as shown in Fig.14, in which the section classification for Indian standard ‘I’ beams have been presented. In other words the flange outstands of the ‘I’ beams rolled in India are so proportioned that they attain yield stress before local buckling. Because of these two reasons, there was no need for section classification in the design of steel beams using IS: 800 (1984). However in the limit state design of steel beams, section classification becomes very essential as the moment capacities of each classified section takes different values, as we will see in the later sections.

6.2 Effect of local buckling in laterally restrained “plastic” or “compact” beams

As mentioned above, laterally restrained “*plastic*” beams while carrying flexural loads sometimes fail to attain their full moment capacity, by the local buckling of the web. The local buckling of slender flanges or slender webs in “*semi-compact*” or “*slender beams*”, is discussed in Chapter -8.

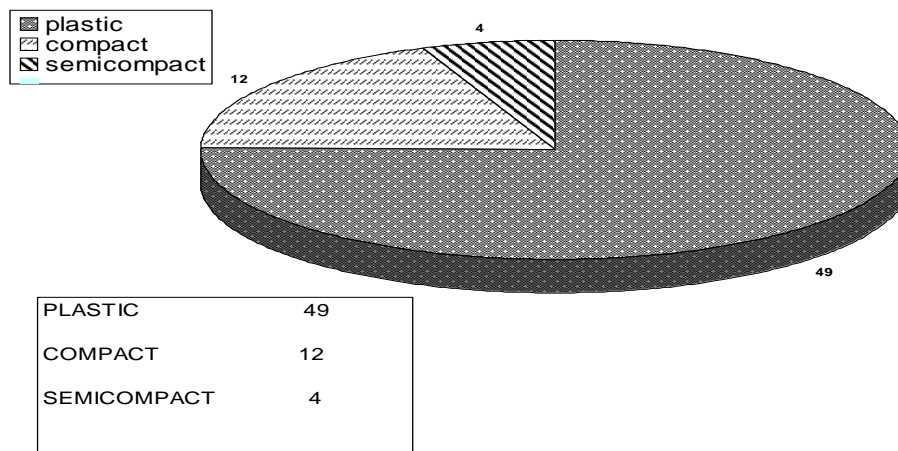

Fig.14 Section classification of Indian standard rolled ‘I’ beams

6.3 Moment capacities of laterally restrained beams

Depending upon the flange criterion (b / T) and web criterion (d / t), as shown in Table 1, laterally restrained beams could be classified as (a) slender, (b) semi-compact, (c) compact, and (d) plastic sections. The flexural behaviour of such beams are presented in Fig.15. As shown in Fig.15, the section classified as ‘slender’ can not attain the first yield moment because of a premature local buckling of the web or flange. The next curve represents the beam classified as ‘semi-compact’ in which the extreme fibre stress in the beam attains yield stress but the beam fails by local buckling before further plastic redistribution of stress could take place towards the neutral axis of the beam. The moment capacity (M_c) of such beams can be obtained as

$$M_c = M_y = \frac{f_y}{\gamma_m} Z \tag{24}$$

where γ_m is the partial safety factor for the material. In the Indian context γ_m is taken as 1.15.

The curve shown as ‘compact beam’ in which the entire portion, both the compression and tension portion of the beam, attains yield stress. Because of this plastic redistribution of stress, the member has attained its plastic moment capacity (M_p) but fails by local buckling before developing plastic mechanism by sufficient plastic hinge rotation. The moment capacity of such a section can be calculated as

$$M_c = \frac{f_y}{\gamma_m} S < 1.2 \frac{f_y}{\gamma_m} Z \tag{25}$$

where S is the plastic section modulus of the cross section. An upper bound value for this moment capacity has been prescribed in codes of practice, to ensure that plasticity does not occur at working loads. (This is done by limiting S value to $1.2 Z$)

Table1: Sectional classification

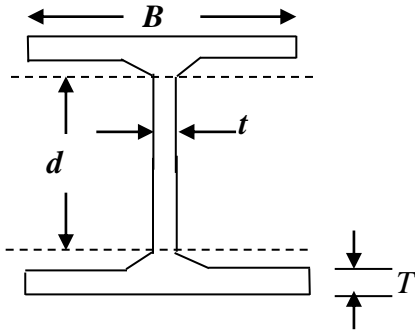
$b = B/2$			$\epsilon = \sqrt{\frac{250}{f_y}}$
	Section type	Flange criterion (b/T)	
	Slender	$> 15.8 \epsilon$	$> 126 \epsilon$
	Semi-compact	10ϵ to 15.8ϵ	103ϵ to 126ϵ
	Compact	8.9ϵ to 10ϵ	83ϵ to 103ϵ
	Plastic	$< 8.9 \epsilon$	$< 83 \epsilon$

Usually for I-beams the shape factor would be less than 1.2 and only for hollow sections the value of S/Z is greater than 1.2. The basic difference between the curves for 'plastic' and 'compact' sections lies in the amount of rotation they sustain at the plastic moment. Usually plastic beams sustain larger rotation at the plastic moment to develop full mechanism. The above discussion gives an idea as to how moment capacities of beams vary with different ranges of constituent plate elements as shown in Table 1.

6.4 Combined bending and shear

In 'I' sections, the flanges predominantly resist the moment and the webs predominantly resist the shear as shown in Fig.8 (a). However, in the case of plastic redistribution of stress over the cross section, the web also is required to contribute to the flexural action as shown in Fig.8 (b)&(c). Hence the shear capacity of the web gets reduced and this becomes very important especially when the web has to carry a relatively high shear and also a high bending moment at the same cross section as in

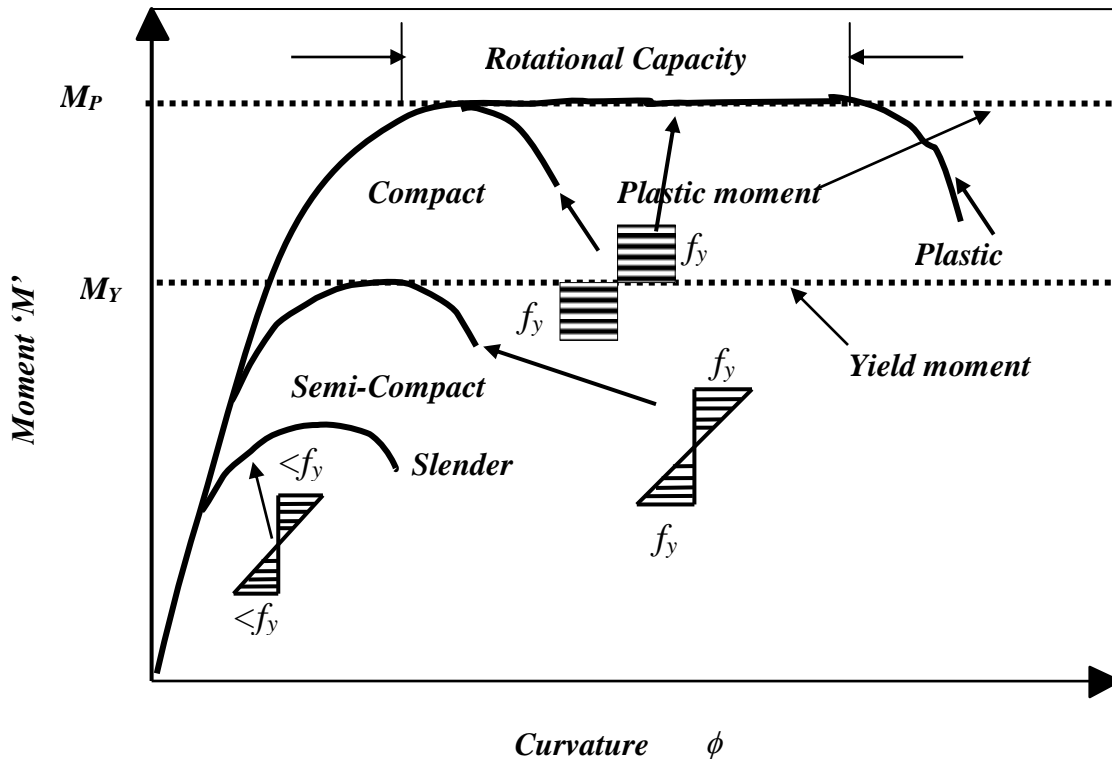

Fig. 15 Flexural member performance using section classification

the case of supports of continuous beams. As larger part of the web yields in flexure, the maximum shear stress in the remaining web reaches the yield stress in shear. To take care of this, the codes specify, that if the external shear load is greater than 0.6 times the shear capacity of the web, then the effect of shear should be considered in the calculation of plastic moment capacity of the cross section. Hence a reduction is applied to the fully plastic moment capacity as

$$M_c = \frac{f_y}{\gamma_m} (S - S_v \rho_I) < 1.2 \frac{f_y}{\gamma_m} Z \quad (26)$$

where

$\rho_I = 2.5(F_v / P_v) - 1.5$ and S_v is the plastic modulus of the shear area, P_v, F_v are respectively the shear capacity of the web and the shear acting at the section.

7.0 UNSYMMETRICAL BENDING

From elementary Strength of Materials, we know that each beam cross section has a pair of mutually perpendicular axes, known as the principal axes. If bending occurs about any axis other than the principal axis, the plane of loading and plane of bending need not coincide. This is referred to as unsymmetrical bending. When the bending takes place about either of the principal axes, the plane of loading and plane of bending coincide. When loads are applied in an inclined direction (as in the case of purlins), they can be resolved into two components perpendicular to the principal axes, as shown in Fig.16, and the moment components M_x and M_y can be calculated. Thereafter it is a simple matter of calculating the two bending stresses separately and algebraically adding them.

7.1 Symmetrical sections

In the elastic design, we can write the resolved components as

$$f_x + f_y \leq p_b \quad (27)$$

where f_x and f_y are the maximum bending stresses at the cross section and p_b is the permissible bending stress. We must be careful when dealing with sections such as angles for which the principal axes are not the geometric axes (i.e. x and y-axes).

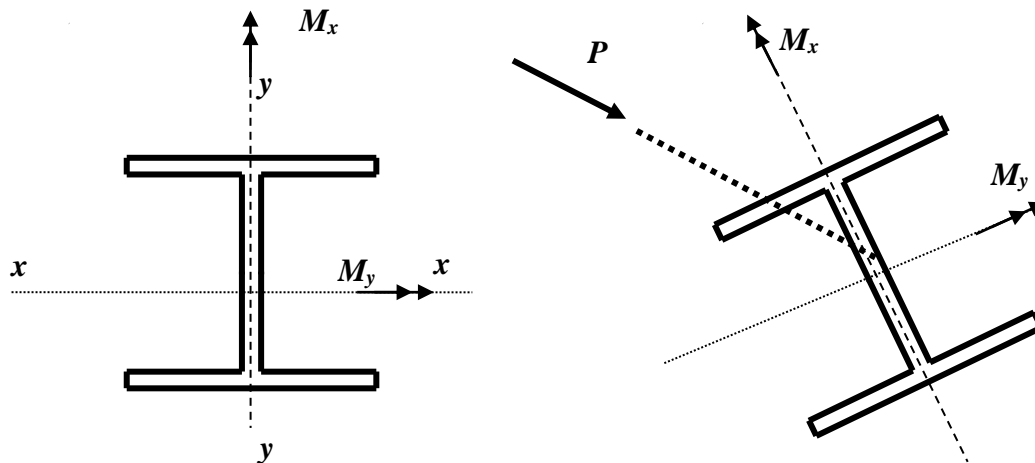

Fig 16 Unsymmetrical bending

When using the plastic strength of the cross section (in the case of '*plastic*' sections) the interaction between moment M_x and M_y will depend on the geometry of the cross section. As an illustration, BS: 5950 Part -1, provides an interaction equation as

$$\left(\frac{M_x}{M_{cx}}\right)^{z_1} + \left(\frac{M_y}{M_{cy}}\right)^{z_2} \leq 1.0 \quad (28)$$

where M_{cx} , M_{cy} are the moment resistance of the cross section about the x and y axes. z_1 and z_2 depend on the geometry of the cross section. Safe values of $z_1=z_2=1.0$ can be used as a first approximation.

7.2 Unsymmetrical sections

In the previous section we described the bending of symmetrical sections, which undergo unsymmetrical bending due to inclined application of loads with respect to the principal axes. There are instances where a vertical load parallel to the x-axis could cause unsymmetrical bending, such as angles and 'Z' sections. As shown in Fig.17, the principal axes of these sections $u-u$ and $v-v$, do not coincide with the orthogonal $x-x$ and $y-y$ axes.

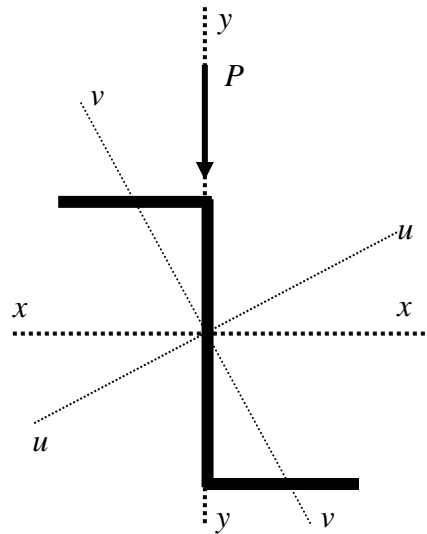

(a) Point symmetry

Fig.17 Z-section prone to unsymmetrical bending

In such cases, the same simplification as in the case of symmetrical sections can be used. However the points of maximum stresses, $f_{x,max}$ and $f_{y,max}$, may not occur at the same point. Hence the maximum stresses $f_{x,max}$ and $f_{y,max}$ must be calculated at various points. After superposition of these two stresses, the maximum value of stress, of all the points in the cross section, has to be used in the design.

7.3 Influence of plane of loading on the flexural behaviour of steel beams

When the load is applied through the centroid, (Fig.18) in the case of the I beam it deflects in the direction of the load. The channel section deflects straight down with a twist. For bending to occur without the twisting of such cross sections, the load must be applied through the '*shear centre*' of the cross section. Shear Centre may be defined as a

point through which load must pass so that twisting of the cross section does not occur during bending. This is exemplified in Fig.19, in which the section undergoes bending without twist when load is applied through the shear centre. If a cross section contains an axis of symmetry, its shear centre lies on that axis. If the cross section is symmetric about two axes or it is point symmetric, then shear centre coincides with the centroid. If the section has two elements joined together (e.g. angles) then the shear centre is at the juncture of the two elements.

Many times we encounter steel sections such as crane girders, which do not have two axes of symmetry. Such steel sections, which are prone to bending with twist, could be made to bend in a desired plane by providing physical constraints as shown in Fig.20. Such behaviour is called the ‘*constrained bending*’

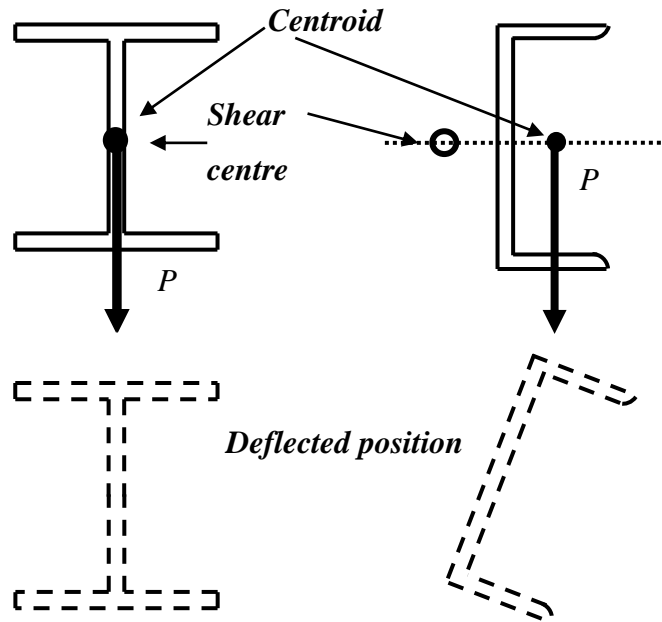

Fig:18 Deflection of beams loaded through the centroid

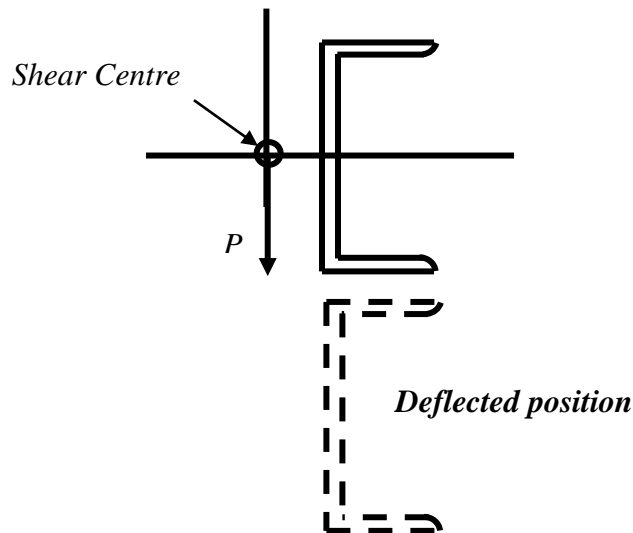

Fig.19 Deflection of channel beam loaded through the shear centre

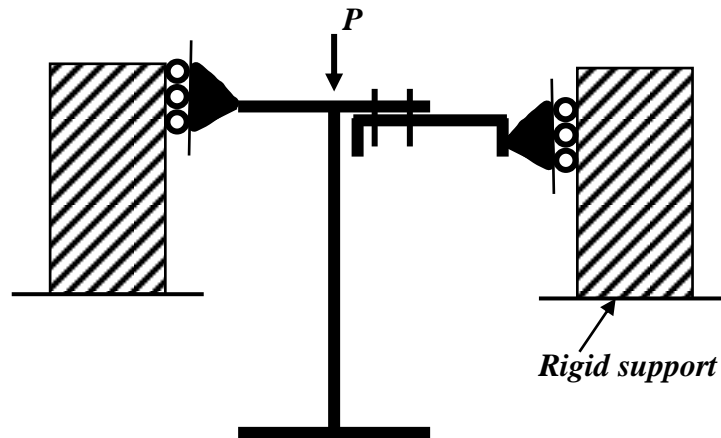

Fig.20 Constrained bending

8.0 BUILT-UP BEAMS

For many steel structures, beams may be provided from among the standard range of rolled steel sections. However, situation may arise when none of the available sections has sufficient moment capacity or there may be a restriction on the depth of the beam due to architectural considerations. Such situations may also occur when it is necessary to provide beam for longer spans or to support a heavy load. Gantry girders are the best example of such cases and strengthening of existing beams is also another example. One of the solutions to such a situation is to use a built-up section as shown in Fig.21. Consider for example, the cover-plated beam as shown in Fig.21 (a). The moment of inertia of the built-up beam is increased compared to the individual rolled section. Neglecting the moment of inertia of the added plate about its own 'x' axis, there would be an increase in moment of inertia of approximately $A(d/2)^2$ for every plate added to the rolled beam. For the section shown in Fig.21 (a), the moment of inertia of the built-up section I_b is written as

$$I_b \approx I_s + 2A\left(\frac{d}{2}\right)^2 \quad (29)$$

where I_s is the moment of inertia of the rolled section. It is more convenient to work in terms of section modulus than moment of inertia. The approximate value of section modulus Z_b (since $d/2$ is not the extreme fibre distance) for the built up section shown in Fig.21 (a) could be written as

$$Z_b \approx Z_s + \frac{2A(d/2)^2}{d/2} = Z_s + Ad \quad (30)$$

where Z_s is the section modulus of the rolled section. The above expression helps in estimating the cover plate area required (although the exact value of Z_b must be verified by calculation, particularly when one plate is added to the top flange). If by design considerations, only one cover plate is to be added to rolled beam (to reduce fabrication cost), then this plate should be fastened to the compression flange. However, if the

thickness of a cover plate added to only one flange exceeds about 1.5 times the thickness of the flange of the rolled section, then adding a cover plate to both the flanges is structurally more efficient. All the outstands of the cover plate is to be checked for its slenderness so as to eliminate the possibility of local buckling. Whenever one or more plates are added to form the built-up section usually the slenderness of individual plates should be considered.

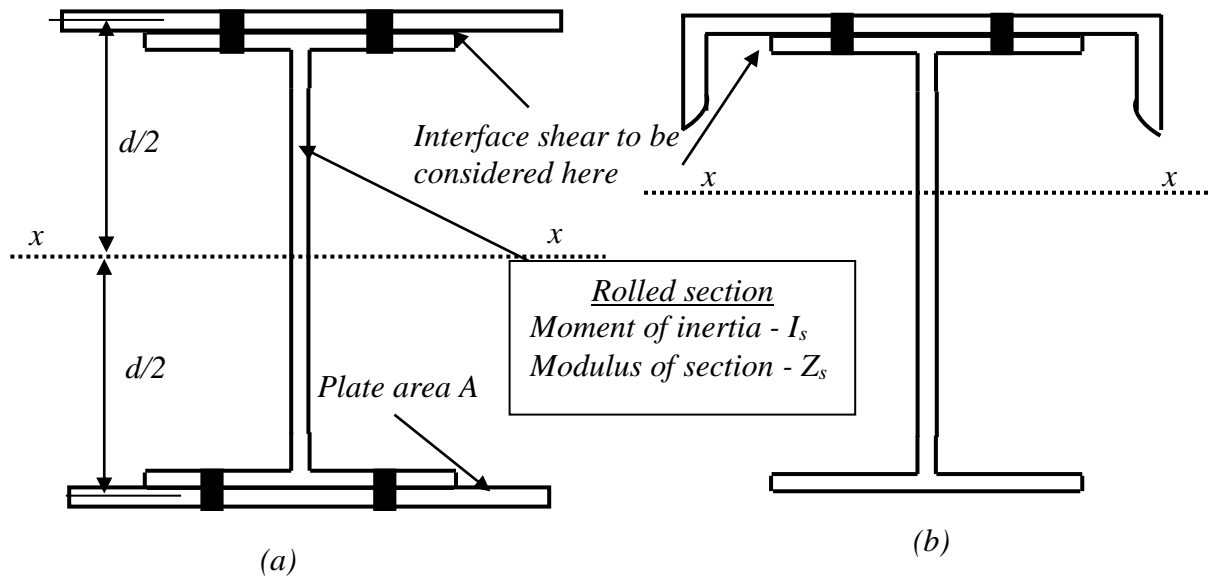

Fig.21 Example of built-up beams

The cover plate and the rolled beam should be adequately connected with welding or bolting, so as to satisfactorily transfer the interface shear between beam and plate. The longitudinal spacing of these welds or bolts must be sufficiently close so as to avoid the plate in the compression flange buckling as an individual strut between the intermittent fasteners. For connecting the cover plate and the rolled beam bolting or welding may be required. In the case of bolting, holes in the flanges become inevitable. These holes cause reduction in the flange area in the tension side. However experimental work on flexure of cover plated steel beams has shown that the failure is based primarily on the strength of the compression flange even though there are bolt holes in the tension side. The presence of these holes does not seem to be serious. Based on this reason, AISC (American Institute of Steel Construction) code suggests that no subtraction for holes need to be made for flange area, if the area of the holes is not more than 15% of the gross area of the flange. However many codes of practice have adopted the conservative procedure of accounting for reduction in flange area due to bolt holes. In practice, the stresses are worked out initially disregarding the reduction in the tension flange area due to holes. Actual tensile stress is obtained by multiplying the stresses calculated as above, by the ratio of gross to the net area (deduction made for tension only) of the respective flange sections. The flange is taken as the flange area of the rolled section and the area of the cover plate.

For the integral action of the rolled beam and the cover plate the interface shear must be adequately transferred. Using Eq.11 the longitudinal shear per unit length to be resisted by these bolts or weld could be written as

$$v = \frac{VQ}{I} \quad (31)$$

where V, Q and I are defined in Eq.11. Using staggered bolts of bolt value ' R ' the staggered pitch of the bolts of the connection between plate and rolled beam could be calculated as

$$p = \frac{R}{(VQ/I)} \quad (32)$$

where ' p ' is the pitch of the staggered bolts. The bolts must be spaced not less than 2.5 times diameter of the hole. The maximum spacing is 32 times the thickness of the plate or 300 mm whichever is less. In the case of welded cover plated beams, no weakening of the tension flange need be considered.

8.1 Curtailment of cover plates

The cover plate will be necessary in the middle portion of the beam where the bending moment is high. Towards the supports, the moment capacity M_c of the rolled section alone would be sufficient to resist the external bending moment. Hence in such portions, the flange plate may be cut off as shown in Fig. 22.

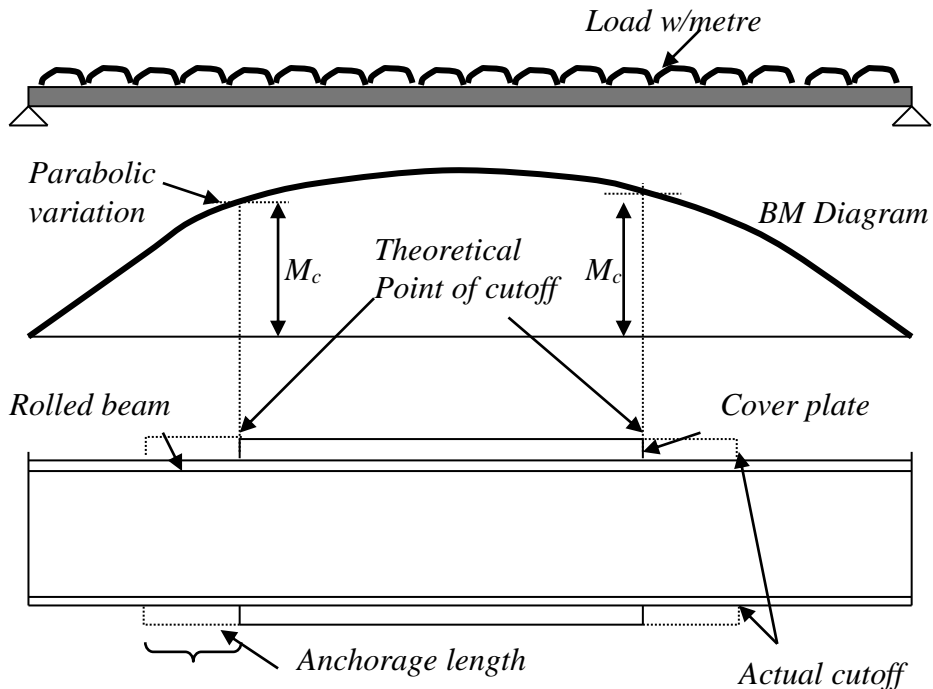

Fig.22 Curtailment of cover plate

Theoretically, the cut off point is the section at which external bending moment is equal to moment capacity of rolled section. However, in practice they are extended further, in order to accommodate bolts or welds and to develop the force in the plate for the bending moment at the point of cut off or in other words to provide anchorage length.

9.0 SUMMARY

In this chapter the fundamentals of the behaviour of laterally restrained beams have been brought out. The limit states of steel beams are discussed. The section classification of beams has been introduced with respect to flexural behaviour of steel beams. Design aspects of built-up beam have also been presented. A worked example illustrates the concept of Limit state Design as applied to beams.

10.0 FURTHER READING

1. David Nethercot, “Limit State Design of Structural Steelwork”, Van Nostrand Reinhold, (1986).
2. Introduction to Steelwork Design to BS:5950 Part I, The Steel Construction Institute, Ascot, UK (1988).
3. Samuel H. Marcus, “Basis of Structural Steel Design”, Reston Publishing Co., Virginia, (1977).

<h1>Structural Steel Design Project</h1> <h2>Calculation Sheet</h2>	Job No. Ex .1	Sheet 1 of 4	Rev.
	Job. Title: <i>LATERALLY RESTRAINED BEAMS</i>		
	<i>Worked Example -1</i>		
	Made by SAJ	Date 21.03.2000	
	Checked by SS	Date 26.03.2000	

<p><u>EXAMPLE: 1</u></p> <p><i>Design a suitable 'I' beam for a simply supported span of 3 m and carrying a dead or permanent load of 17.78 kN/m and an imposed load of 40 kN/m. Assume full lateral restraint and stiff support bearing of 100 mm.</i></p> <div style="text-align: center;"> <p>(DL 17.78 kN + LL 40 kN) / metre</p> </div> <p><u>Design load calculation:</u></p> <p>factored load = $\gamma_{LD} \times 17.78 + \gamma_{LL} \times 40$ kN</p> <p><i>in this example the following load factors are chosen.</i></p> <p>γ_{LD} and γ_{LL} are taken as 1.35 and 1.50 respectively.</p> <p>γ_{LD} – partial safety factor for dead or permanent loads γ_{LL} – partial safety factor for live or imposed loads</p> <p>Total factored load = $1.35 \times 17.78 + 1.5 \times 40.0 = 84$ kN / m</p> <p>Factored bending moment = $84 \times 3^2 / 8 = 94.50$ kN – m</p> <p>Z—value required for $f_y = 250$ MPa ; $\gamma_m = 1.15$</p> $Z_{reqd} = \frac{94.5 \times 1000 \times 1000 \times \gamma_m}{250}$ <p>$Z_{reqd} = 434.7$ cm³</p>	$\gamma_{LD} = 1.35$ $\gamma_{LL} = 1.50$
---	--

<h1>Structural Steel Design Project</h1> <p>Calculation sheet</p>	Job No. Ex .1	Sheet 2 of 4	Rev.
	Job. Title: <i>LATERALLY RESTRAINED BEAMS</i>		
	<i>Worked Example - 1</i>		
	Made by SAJ	Date	21.03.2000
	Checked by SS	Date	26.03.2000
<p><u>Try ISMB 250</u></p> $\varepsilon = \sqrt{\frac{250}{250}} = 1.0 \quad D = 250 \text{ mm}$ $B = 125 \text{ mm}$ $t = 6.9 \text{ mm}$ $T = 12.5 \text{ mm}$ $I_{xx} = 5131.6 \text{ cm}^4$ $I_{yy} = 334.5 \text{ cm}^4$ <p><u>Section classification:</u></p> <p>Flange criterion = $B/2T = 5$.</p> <p>Web criterion = $(D - 2T)/t = 32.61$</p> <p>Since $B/2T < 8.92 \varepsilon$ & $(D-2T)/t < 82.95 \varepsilon$</p> <p>The section is classified as 'PLASTIC'</p> <p><u>Moment of resistance of the cross section:</u></p> <p>Since the section considered is 'PLASTIC'</p> $M_c = \frac{S \times f_y}{\gamma_m}$ <p>Where S is the plastic modulus</p> <p>'S' for ISMB 250 = 459.76 cm^3</p> $M_c = 459.76 \times 1000 \times 250 / 1.15$ $= 99.95 \text{ kN-m} > 94.5 \text{ kN-m}$ <p>Hence ISMB-250 is adequate.in flexure.</p>			

Structural Steel Design Project Calculation sheet	Job No. Ex .1	Sheet 3 of 4	Rev.
	Job. Title: <i>LATERALLY RESTRAINED BEAMS</i>		
	<i>Worked Example- 1</i>		
	Made by SAJ	Date	21.03.2000
Checked by SS	Date	26.03.2000	
<p><u>Shear resistance of the cross section:</u></p> <p><i>This check needs to be considered more importantly in beams where the maximum bending moment and maximum shear force may occur at the same section simultaneously, such as the supports of continuous beams. For the present example this checking is not required. However for completeness this check is presented.</i></p> <p>Shear capacity $P_v = \frac{0.6 f_y A_v}{\gamma_m}$</p> <p>$A_v = 250 \times 6.9 = 1725 \text{ mm}^2$</p> <p>$P_v = 0.6 \times 250 \times 1725 / 1.15 = 225 \text{ kN}$</p> <p>$F_v = \text{factored max shear} = 84 \times 3 / 2 = 126. \text{ kN}$</p> <p>$F_v / P_v = 126 / 225.0 = 0.56 < 0.6$</p> <p><i>Hence the effect of shear need not be considered in the moment capacity calculation.</i></p> <p><u>Check for Web Buckling:</u></p> <p><i>The slenderness ratio of the web = $L_E / r_y = 2.5 d / t = 2.5 \times 194.1 / 6.9$</i></p> <p style="text-align: center;">$= 70.33$</p> <p><i>The corresponding design compressive stress f_c is found to be</i></p> <p style="text-align: center;">$f_c = 203 \text{ MPa}$ (Design stress for web as fixed ended column)</p> <p><i>Stiff bearing length = 100 mm</i></p> <p><i>45° dispersion length $n_1 = 125.0 \text{ mm}$</i></p> <p>$P_w = (100 + 125.0) \times 6.9 \times 203.0$</p> <p style="text-align: center;">$= 315.16 \text{ kN}$</p> <p style="text-align: center;">$315.16 > 126$ <i>Hence web is safe against shear buckling</i></p>			

Structural Steel Design Project Calculation sheet	Job No. Ex .1	Sheet 4 of 4	Rev.
	Job. Title: <i>LATERALLY RESTRAINED BEAMS</i>		
	<i>Worked Example - 1</i>		
	Made by SAJ	Date 21.03.2000	
	Checked by SS	Date 26.03.2000	
<u>Check for web crippling at support</u>			
<i>Root radius of ISMB 250 = 13 mm</i>			
<i>Thickness of flange + root radius = 25.5 mm</i>			
<i>Dispersion length (1:2.5) $n_2 = 2.5 \times 25.5 = 63.75 \text{ mm}$</i>			
<i>$P_{crip} = (100+63.75) \times 6.9 \times 250 / 1.15$</i>			
<i>= 245.63 kN > 126kN</i>			
<i>Hence ISMB 250 has adequate web crippling resistance</i>			
<u>Check for serviceability – Deflection:</u>			
<i>Load factors for working loads γ_{LD} and $\gamma_{LL} = 1.0$</i>			
<i>design load = 57.78 kN/m.</i>			
$\delta = \frac{5 \times 57.78 \times 3000^4}{384 \times 2.1 \times 10^5 \times 5131.6 \times 10^4}$			
<i>Max deflection = 5.65 mm</i>			
$= \frac{L}{531}$			
$\frac{L}{531} < \frac{L}{200}$			
<i>Hence serviceability is satisfied</i>			
<u>Result :- Use ISMB – 250.</u>			