

## 1.0 INTRODUCTION

The need for connections and the importance of connection designs in steel structures have been covered in an earlier chapter. It has been pointed out that steel sections are linear elements produced in certain convenient lengths due to constraints on manufacturing and transportation. Therefore connections are necessary to provide continuity, where required, as well as to create three-dimensional steel structures. One of the most efficient and possibly direct ways of providing connections in steel structures is by way of *welding*.

Welding is the process of joining two pieces of metal by creating a strong metallurgical bond between them by heating or pressure or both. It is distinguished from other forms of mechanical connections, such as riveting or bolting, which are formed by friction or mechanical interlocking. It is one of the oldest and reliable methods of jointing.

Welding was quite an art prevalent in ancient Greece to make bracelets. It was probably a forging process, where metals were heated and hammered together. Modern welding has been in existence since World War I. It was mainly used for repairing damaged ships. After 1919, the use of welding as a construction and fabrication method began to develop. Since then many improvements and developments have taken place. Today there are over 50 different welding processes, which can be used to join various metals and their alloys.

## 2.0 ADVANTAGES OF WELDING

Welding offers many advantages over bolting and riveting. Some of the advantages are listed in the following.

- Welding enables direct transfer of stress between members. Hence, the weight of the joint is minimum. Besides efficiency, design details are very simple. Less fabrication cost compared to other methods due to handling of fewer parts and elimination of operations like drilling, punching etc. The most striking advantage of welded structures is in the area of economy. Welded structures allow the elimination of a large percentage of the gusset and splice plates necessary for riveted or bolted structures. Time is saved in detailing, fabrication and field erection. In some bridge trusses it may be possible to save up to 15% of the steel weight by resorting to welding. Welding also requires considerably less labour for executing the work.
- Welding offers air tight and water tight joining of plates and hence ideal for oil storage tanks, ships etc.

© Copyright reserved

- Welded structures usually have a neat appearance as against the cluttered surface of bolted or riveted connections. Fig. 1 shows a comparison of riveted plate girder and a welded plate girder. Further, welded connections offer the designer more freedom for innovation in his design concept. It enables him to use any cross section and the best configuration to transmit forces from one member to another.

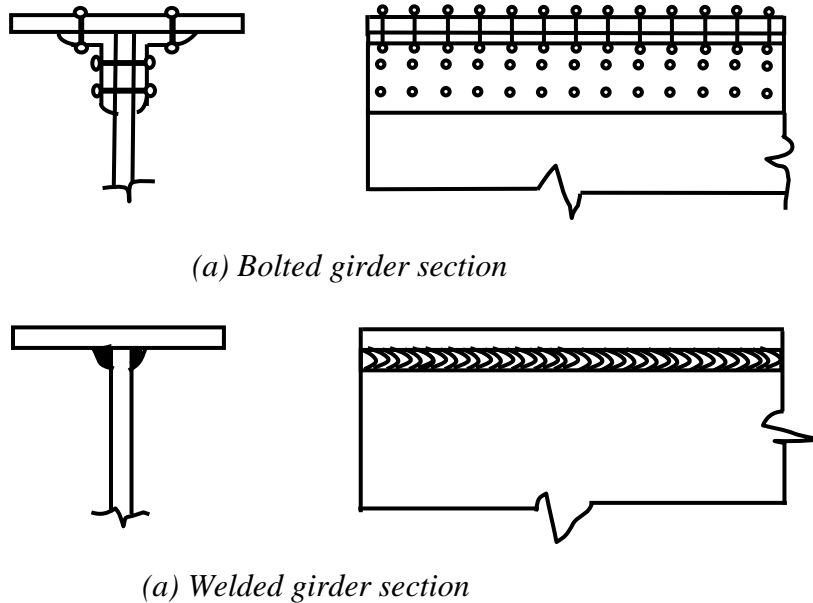

**Fig.1 Comparison of appearance of riveted and welded plate girders**

- The range of application of welding is very wide. For example, connection of a steel pipe column to other members can be made very easily by welding whereas it is virtually impossible by bolting or riveting. Welding is practicable even for complicated shapes of joints.
- There is no need for holes in members connected by welding except possibly for erection purposes. This has direct influence in the case of tension members as the problem of determining the minimum net section is eliminated. This also results in a member with a smaller cross section.
- Welded structures are more rigid compared to structures with riveted and bolted connections. The rigidity of welded structures is due to the direct connection of members by welding. In bolted or riveted structures, the connection is established through angles or plates, which deflect under loads, making the structure flexible.
- It is easier to make design changes and to correct mistakes during erection, if welding is used. It is also a simple procedure to strengthen the existing structures with welding.
- A truly continuous structure is formed by the process of fusing the members together. This gives the appearance of a one-piece construction. Generally welded joints are as strong or stronger than the base metal, thereby placing no restriction on the joints.

Due to this continuity advantage, a very large number of steel frames have been constructed all over the world.

- Stress concentration effect is considerably less in a welded connection. Some of the lesser important advantages of the welding processes are: relative silence of the process of welding and fewer safety precautions.

Some of the disadvantages of welding are:

- Welding process requires highly skilled manpower
- Experienced manpower is needed for inspection of welded connections. Also, non-destructive evaluation may have to be carried out to detect defects in welds
- Welded joints are highly prone to cracking under fatigue loading
- Costly equipment is essential to make welded connections
- Proper welding can not be done in the field environment
- Large residual stresses and distortion are developed in welded connections

In the earlier days, combination of bolting, riveting and welding was not practiced. Structures were completely welded, bolted or riveted. Presently both are used in a structure except that both connection techniques are not used in one and the same joint. The present trend is to use welding for workshop connections or splices, and high strength bolts for field joints.

### 3.0 FUNDAMENTALS OF WELDING

A welded joint is obtained when two clean surfaces are brought into contact with each other and either pressure or heat, or both are applied to obtain a bond. The tendency of atoms to bond is the fundamental basis of welding. The inter-diffusion between the materials that are joined is the underlying principle in all welding processes. The diffusion may take place in the liquid, solid or mixed state. In welding the metallic materials are joined by the formation of metallic bonds.

When two clean and flat surfaces are joined, the bonding takes place between surface atoms and a perfect connection is formed (Fig.2).

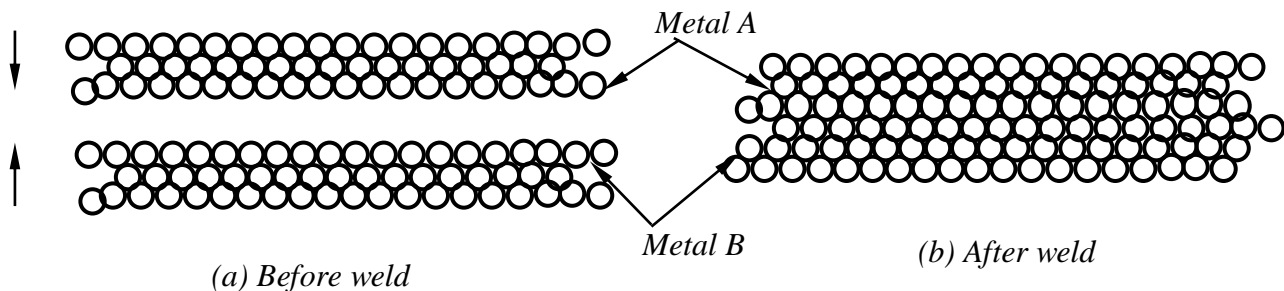

*Fig.2 Two ideal surfaces brought together to form a weld*

The efficiency obtained for the joint is 100% and its strength would be as much as that of the base metals. In practice however, it is very difficult to achieve a perfect joint; for, real surfaces are never smooth. When irregular surfaces are joined by welding, contact is established only at a few points in the surface, where atomic bonding occurs. Therefore the strength attained will be only a fraction of the full strength. Also, the irregular surface may not be very clean, being contaminated with adsorbed moisture, oxide film, grease layer etc. as shown in Fig 3(a).

In the welding of such surfaces, the contaminants have to be removed for the bonding of the surface atoms to take place. This can be accomplished by applying either heat or pressure. In practical welding, both heat and pressure are applied to get a good joint.

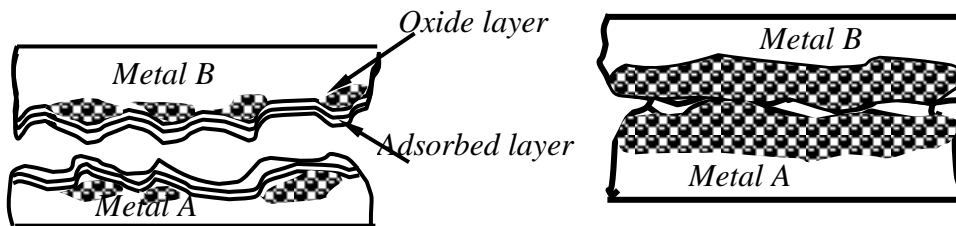

**Fig.3 (a) Surface contaminants**

**Fig. 3(b) Addition of filler material**

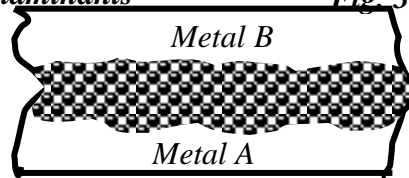

**Fig.3(c) Near perfect weld**

When heat is applied, the adsorbed layers are driven off, oxide films are broken and the yield strength of the base metals are lowered; with the application of pressure, plastic deformation takes place and brings into contact more atoms for welding. Heat application results in the melting of the metallic members, enabling atoms to come into contact by fluid flow and form bonds. Sometimes, a filler material, of the same type as the base material or compatible with it, is added to achieve the bond [Fig 3(b)]. When pressure is applied to form a joint it breaks the obstructing layers and sharp edges to bring the joining surfaces together for making the bond. Fig. 3(c) shows a weld formed by the application of heat and pressure.

As pointed out earlier, any welding process needs some form of energy, often heat, to connect the two materials. The relative amount of heat and pressure required to join two materials may vary considerably between two extreme cases in which either heat or pressure alone is applied. When heat alone is applied to make the joint, pressure is used merely to keep the joining members together. Examples of such a process are Gas Tungsten Arc Welding (GTAW), Shielded Metal Arc Welding (SMAW), Submerged Arc Welding (SAW) etc., which are explained later. On the other hand pressure alone is used to make the bonding by plastic deformation, examples being cold welding, roll welding, ultrasonic welding etc. There are other welding methods where both pressure and heat are

employed, such as resistance welding, friction welding etc. The required heat is produced by a flame, an arc or resistance to an electric current. Electric arc is by far the most popular source of heat used in commercial welding practices.

#### **4.0 BASIC WELDING PROCESSES**

In general, gas and arc welding are employed; but, almost all structural welding is arc welding.

In gas welding a mixture of oxygen and some suitable gas is burned at the tip of a torch held in the welder's hand or by an automatic machine. Acetylene is the gas used in structural welding and the process is called oxyacetylene welding. The flame produced can be used both for cutting and welding of metals. Gas welding is a simple and inexpensive process. But, the process is slow compared to other means of welding. It is generally used for repair and maintenance work.

The most common welding processes, especially for structural steel, use electric energy as the heat source produced by the electric arc. In this process, the base metal and the welding rod are heated to the fusion temperature by an electric arc. The arc is a continuous spark formed when a large current at a low voltage is discharged between the electrode and the base metal through a thermally ionised gaseous column, called plasma. The resistance of the air or gas between the electrode and the objects being welded changes the electric energy into heat. A temperature of  $3300^{\circ}\text{C}$  to  $5500^{\circ}\text{C}$  is produced in the arc.

The welding rod is connected to one terminal of the current source and the object to be welded to the other. In arc welding, fusion takes place by the flow of material from the welding rod across the arc without pressure being applied.

#### **4.1 Arc Welding Processes**

Different processes of arc welding are explained in the following sections:

##### ***4.1.1 Shielded Metal Arc Welding (SMAW)***

In Shielded Metal Arc Welding or SMAW (Fig. 4), heating is done by means of electric arc between a coated electrode and the material being joined. In case bare wire electrode (without coating) is employed, the molten metal gets exposed to atmosphere and combines chemically with oxygen and nitrogen forming defective welds. The electrode coating on the welding rod forms a gaseous shield that helps to exclude oxygen and stabilise the arc.

The coated electrode also deposits a slag in the molten metal, which because of its lesser density compared to the base metal, floats on the surface of the molten metal pool, shields it from atmosphere, and slows cooling. After cooling, the slag can be easily removed by hammering and wire brushing.

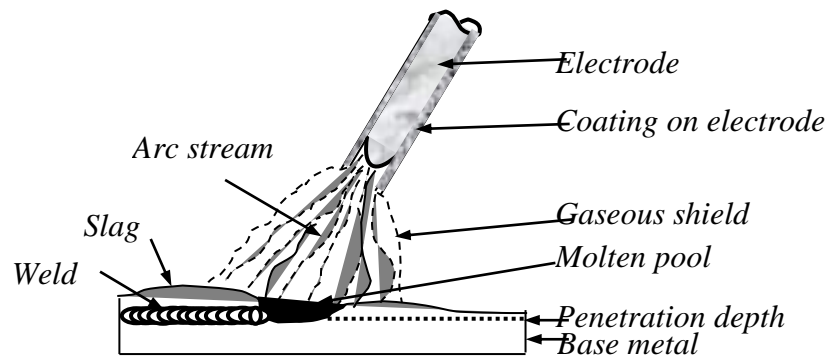

**Fig.4. Shielded Metal Arc Welding (SMAW) process**

The coating on the electrode thus

- Shields the arc from atmosphere
- Coats the molten metal pool against oxidation
- Stabilises the arc
- Shapes the molten metal by surface tension
- Provides alloying element to weld metal

The type of welding electrode used would decide the weld properties such as strength, ductility and corrosion resistance. The type to be used for a particular job depends upon the type of metal being welded, the amount of material to be added and the position of the work. The two general classes of electrodes are lightly coated and heavily coated. The heavily coated electrodes are normally used in structural welding. The resulting welds are stronger, more corrosion resistant and more ductile compared to welds produced by lightly coated electrodes. Usually the SMAW process is either automatic or semi-automatic.

#### 4.1.2 Submerged Arc Welding (SAW)

In this arc welding process, the arc is not visible because it is covered by a blanket of fusible powdered flux. The bare metal electrode is deposited as a joining material. The flux, which is a special feature of the method, protects the weld pool against the atmosphere. The arc once started is at all times covered by the flux as shown in Fig. 5.

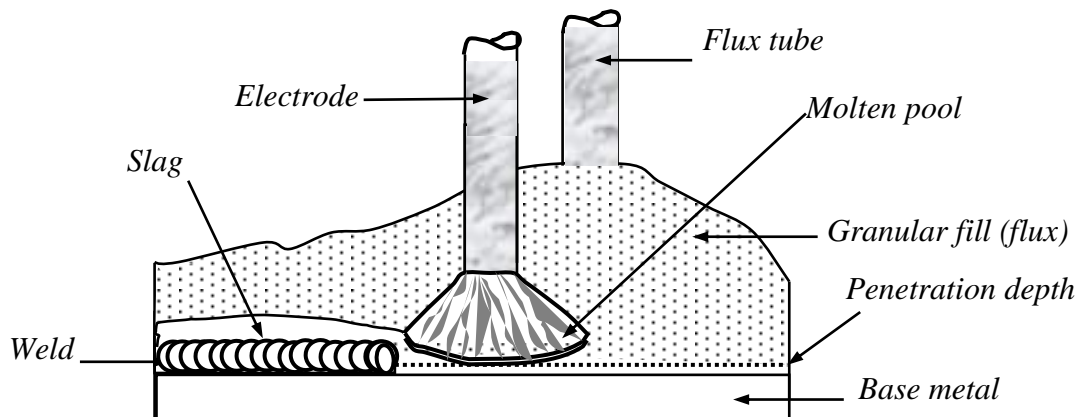

**Fig.5. Submerged arc welding (SAW) process**

The heat of the arc melts the electrode, the object to be welded, and part of the flux. The slag formed by the flux, which forms a coat over the solidified weld beam, may be removed by brushing. Welds made by submerged arc welding process have high quality, good ductility, high impact strength, high density and good corrosion - resistance. Their mechanical properties are as good as the base metal. Since more heat is input in this process, the penetration is deeper than the SMAW process. This is normally taken into account in the design.

#### ***4.1.3 Manual Metal Arc (MMA) Welding***

This is a manually operated welding process and hence requires skill to produce good quality welds. The electrode is made up of a steel core wire (3.2 – 6.0 mm diameter) and the flux contains manganese and silicon as alloying elements. The electric arc melts the metallic object to be welded and the electrode. As the core wire metal melts and joins the weld pool, the electrode is moved to maintain the arc length. This is important as the arc length controls the width of the weld run. The flux also melts with steel core wire and forms the surface slag, which is removed after solidification.

Low capital cost and freedom of movement (up to 20 m from power supply) are the main advantages of MMA welding. It is well suited to structural and stainless steels. Its main disadvantage is that only a small volume of metal is deposited per electrode. This is not a problem for short welds, but for long welds this becomes a serious consideration.

#### ***4.1.4 Metal – Active Gas (MAG) welding***

This is sometimes also referred to as Metal Inert Gas (MIG) welding. The arc and the weld pool are protected by an inert gas; the shielding gas often used is carbon dioxide or a mixture of oxygen and carbon dioxide. Flux is not necessary to shield the pool; however, occasionally a flux - cored electrode is used to produce slag. The arc length is maintained by the power supply unit. Though MAG welding is easier, more skill is required to establish the correct welding conditions. Using MAG welding, production is improved, as there is no need to deslag or change electrode. It is highly suitable for fillet - welded joints, such as beam to beam or stiffener to panel connections. Its disadvantage is due to restriction in movement due to equipment. This can be manual, semi-automatic or automatic process

#### ***4.1.5 Electroslag Welding Process***

The method of Electroslag process (Fig. 6) used for vertical automatic welding is based on the heat produced by electrical current through molten slag. The electrode is immersed in the molten slag pool between the components to be welded and the copper moulding devices. As the melt is heated to a high temperature by current passing between the electrodes and the base metal, the electrical conductivity is increased. The slag pool temperature must exceed the melting points of the base and filler metals. Then the slag melts the faces of the connecting work and the electrode is immersed in the molten slag. The weld pool that forms when the molten base and filler metal collect at the bottom of the slag pool solidifies and forms the weld joining the faces of the members.

Electroslag welding is useful for joining thick sections in a vertical position. Single - pass welds can be made in any reasonable thickness of steel. Welding usually starts at the bottom of the joint and progresses towards the top of the vertical connection.

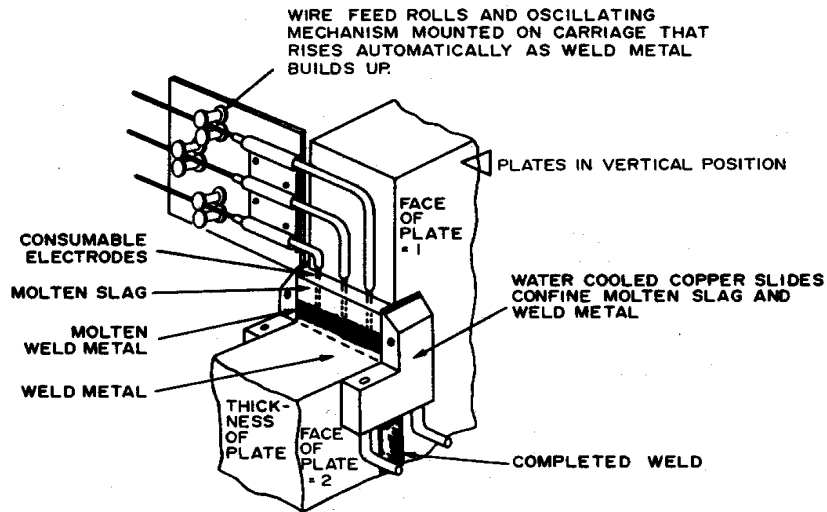

*Fig. 6 Electroslag welding process*

#### 4.1.6 Stud Welding

The shear connectors that are used extensively in composite construction have to be attached to the steel beam by welding. Stud welding is an accurate and best method of attaching shear connectors with minimum distortion. The figure and details of a stud welding machine are given in Chapter 41 on Fabrication and Erection of Structural Steel Work.

Stud welding is another form of arc welding and is mechanised for the welding of studs to plane surfaces. The stud may be a plain bar with an upset head or threaded. The stud itself forms the electrode and is held in a chuck, which is connected to the power source. Initially, the stud is touched on the steel plate or section surface and the current is switched on. Soon the stud is moved away to establish the arc. A weld pool is formed and the stud end melts. Then the stud is forced into the steel plate automatically and the current supply is switched off. The molten metal is collected in an enclosure around the stud formed by a ceramic collar or ferrule. Thus the molten metal is formed into a fillet and is also protected from atmosphere by the ferrule.

#### 4.2 Choice of Process

The choice of a particular process is made based on a number of parameters listed below:

- The location of the welding operation: In a protected place like a fabrication shop, SAW and MAG are best suited. For field conditions MMA is easier.
- Accuracy of setting up: SAW and MAG require good and accurate set-up.
- Penetration of the weld.



- Volume of weld to be deposited
- Access to joint: The welding plant and the welding torches have to be properly positioned during the welding operation. In easily accessible joints SAW or MAG is used, whereas in cramped locations MMA is preferred.
- Position of welding: SAW and MAG are not suitable for overhead positions. MMA is the best for overhead works.
- Steel composition: SAW and MAG do not generally develop HAZ (Heat Affected Zone) cracking. This offsets the disadvantage of MAG for site works.
- Comparative cost: cost of welding is calculated for unit length considering the duty cycles.

## 5.0 WELDING PROCEDURE

### 5.1 General

The term ‘welding procedure’ encompasses the complete operation of making a weld. Thus, it includes choice of electrode, edge preparation, preheat, welding parameters such as voltage, current, welding position, number of weld run to fill the groove and post weld treatments (e.g. grinding, heat treatment etc.). Establishment of such procedures helps to minimise the cost, achieve good impact properties, eliminates defects and controls distortion. Some of the important elements of weld procedure are elaborated below.

**Environment:** Weld procedure must account for actual site conditions. In cold regions, it may be necessary to heat steel up to 20%. The humid weather or condensation might help formation of porosity. Electrodes must be kept in dry condition. In moist / humid environments the electrodes may be kept in a warm container to avoid moisture entrapment in the flux coating.

**Welding position:** Vertical welding is slower compared to welding in the flat position. Overhead welding causes weld splutter and require special skills. It is better avoided.

**Current:** The current controls the heat input. A minimum current is required for fusing the plate and to keep the arc stable. Generally a high current is used to obtain quicker welding so as to reduce cost. It may not be possible to use maximum current always, a specific example being welding in the overhead position. The current limit for overhead use is 160A. Usually high current results in low impact properties. Further very high value of current may cause cracks in the Heat-Affected Zone (HAZ).

**Shrinkage:** While cooling after the welding operation, the hot metal in the welded region contracts causing the joint to shrink. But this contraction is prevented by the adjacent colder metal. This causes stress, sometimes even beyond yield stress, and causes plastic deformation. This also might cause distortion of the member. By following proper edge preparation and weld procedure, this can be minimised. After the plastic deformation a residual stress pattern is formed in the joint. Tensile stresses are formed in the weld metal and HAZ zones, whereas compression in the adjacent steel.

**Pre heating:** Hydrogen induced cracking (cold cracking, delayed cracking) is a serious problem affecting weldability. The degree of cracking occur due to the combined effects of four factors:

1. Brittle microstructure
2. Presence of hydrogen in weld metal
3. Tensile stresses in the weld area
4. Temperature range (-100° C to 200° C)

Pre heating of the weld area is the most effective and widely used method to prevent hydrogen induced cracking. Welding involves a cycle of sudden heating and cooling. By preheating the parent metal, the difference in temperature between the preheated temperature and the final temperature is reduced. This, in the cooling cycle, also helps to obtain a lower thermal gradient. As explained in the first chapter on 'Historical Development and Characters of Structural Steels', sudden cooling of steel results in a hard and less ductile material called martensite. The main function of preheating is to reduce the weld metal cooling rate so that transformation to martensite is reduced below a certain critical level. The slower cooling gives more time for hydrogen to diffuse out of the weld area and delays the development of maximum residual stresses. Gas torches, heat-treating furnaces or electric-resistance heaters are used in preheating the weld area.

## 5.2 Weldability of Steels

The term weldability is defined as the ability to obtain economic welds, which are good, crack - free and would meet all the requirements. Of great importance are the chemistry and the structure of the base metal and the weld metal. The effects of heating and cooling associated with fusion welding are experienced by the weld metal and the Heat Affected Zone (HAZ) of the base metal. The HAZ i.e. base metal surrounding the weld metal and the weld itself will have unduly varying hardness distribution across a weld. The hardness in steel depends upon the rate at which steel is cooled near the fusion zone; the hardness is maximum due to the higher temperature at that location. Further, these locations also have the maximum rate of cooling. Higher value of hardness leads to cracks in HAZ or in the weld. Cracks might be formed during or after the welding process.

Good design and standard welding procedure will minimise the cracking problem. Several features that affect weld cracking during the welding processes are

- Joint restraint that builds up high stress in the weld
- Bead shape (convex or concave)
- Carbon and alloy content of the base metal
- Cooling rate
- Hydrogen and nitrogen absorption

The cracks in HAZ are mainly caused by high carbon content, hydrogen embrittlement and rate of cooling. For most steels, weld cracks become a problem as the thickness of the plates increases.

## 6.0 TYPES OF JOINTS AND WELDS

By means of welding, it is possible to make continuous, load bearing joints between the members of a structure. A variety of joints is used in structural steel work and they can be classified into four basic configurations as shown in Fig. 7.

They are:

1. Lap joint
2. Tee joint
3. Butt joint, and
4. Corner joint

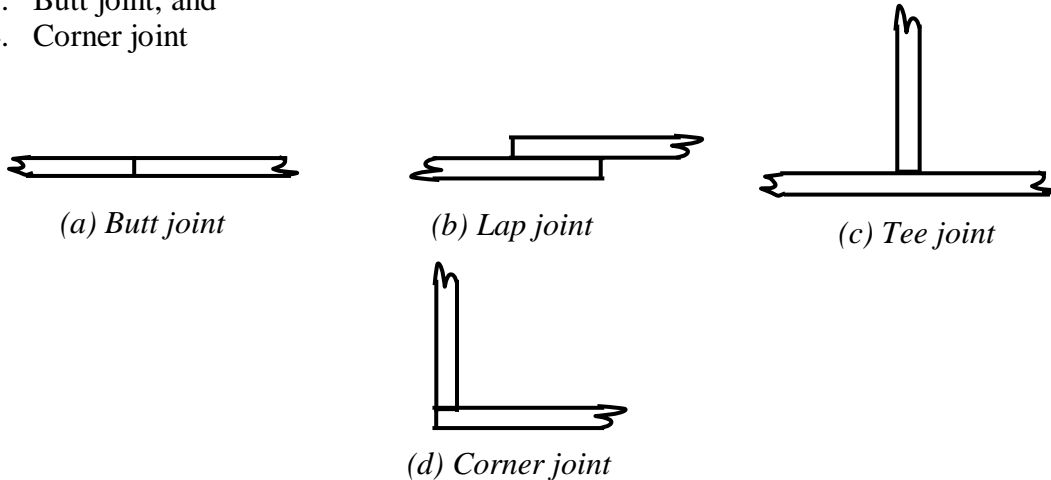
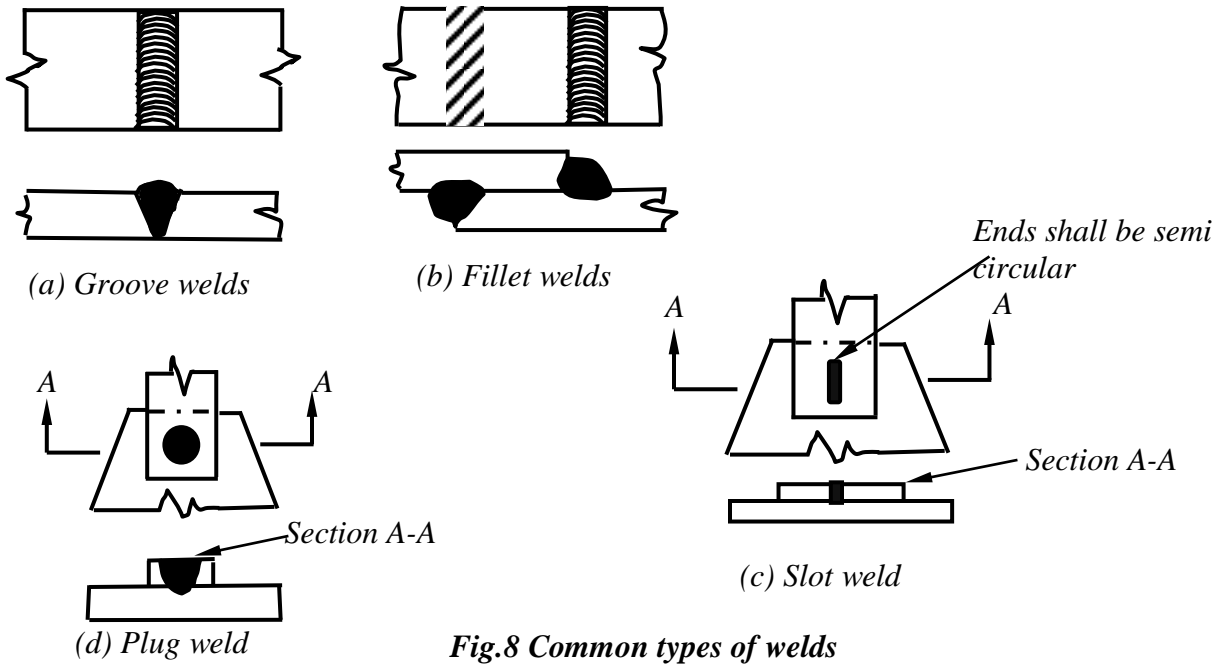

**Fig. 7 Types of joints**

For lap joints the ends of two members are overlapped, and for butt joints the two members are placed end to end. The T- joints form a Tee and in Corner joints, the ends are joined like the letter L. the common types of welds are shown in Fig. 8. Most common joints are made up of fillet weld and the groove weld. Plug and slot welds are not generally used in structural steel work. Fillet welds are suitable for lap joints and Tee joints and groove welds for butt and corner joints. Groove welds can be of complete penetration or incomplete penetration depending upon whether the penetration is complete through the thickness or partial. Generally a description of welded joints requires an indication of the type of both the joint and the weld.

Though fillet welds are weaker than groove welds, about 80% of the connections are made with fillet welds. The reason for the wider use of fillet welds is that in the case of fillet welds, when members are lapped over each other, large tolerances are allowed in erection. For groove welds, the members to be connected have to fit perfectly when they are lined up for welding. Further groove welding requires the shaping of the surfaces to be joined as shown in Fig. 9. To ensure full penetration and a sound weld, a backup plate is temporarily provided as shown in Fig. 9.

Welds are also classified according to their position into flat, horizontal, vertical and overhead (Fig. 10). Flat welds are the most economical to make while overhead welds are the most difficult and expensive.



**Fig.8 Common types of welds**

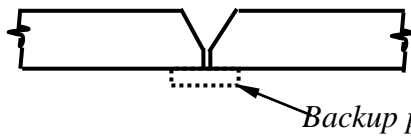

**Fig. 9 Shaping of surface and backup plate**

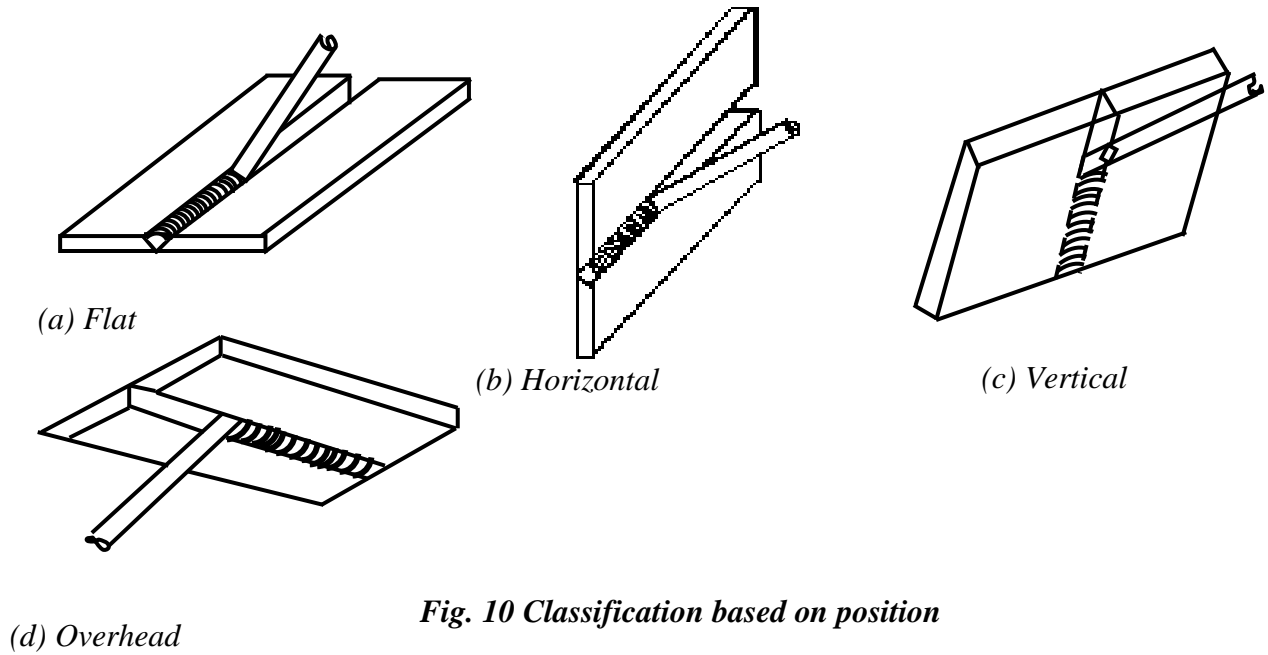
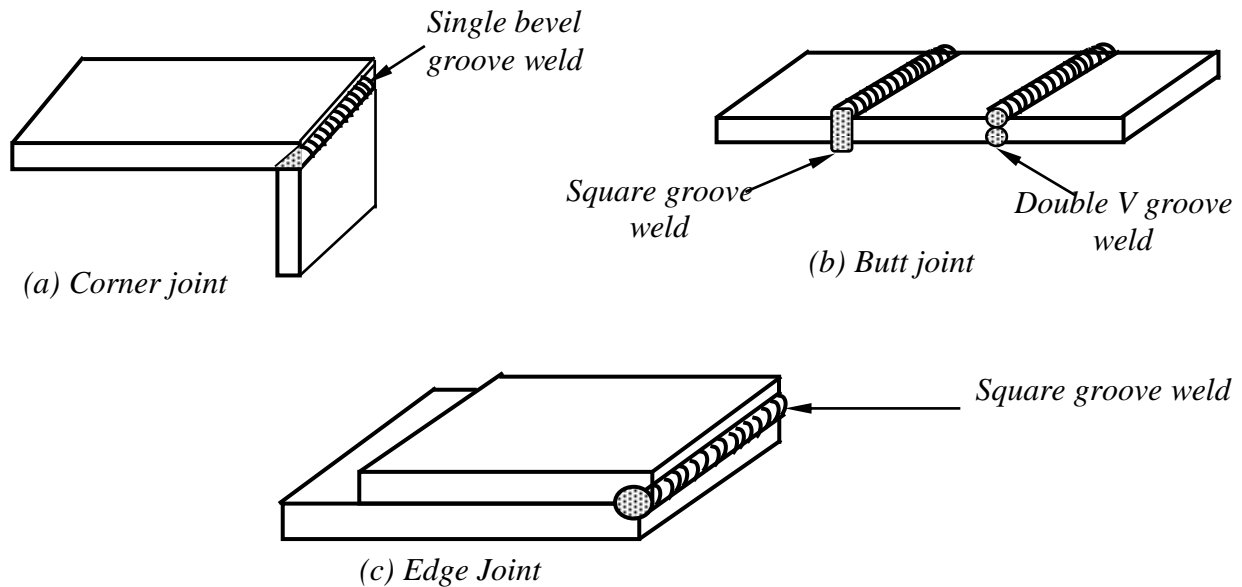

**Fig. 10 Classification based on position**

## 7.0 GROOVE WELDS

The main use of groove welds is to connect structural members, which are in the same plane. A few of the many different groove welds are shown in Fig. 11. There are many variations of groove welds and each is classified according to its particular shape. Each type of groove weld requires a specific edge preparation and is named accordingly. The proper selection of a particular type depends upon

- Size of the plate to be joined.
- Welding is by hand or automatic.
- Type of welding equipment.
- Whether both sides are accessible.
- Position of the weld.



**Fig.11 Typical connections with groove weld**

The aim is to achieve the most economical weld of the requisite efficiency and strength. The butt weld whether of full penetration or partial penetration should attain the required strength of the joined parts. The size of the butt weld is defined by the thickness i.e. the thickness of the connected plate for complete penetration welds or the total depth of penetration for partial penetration welds.

Groove welds have high strength, high resistance to impact and cyclic stress. They are most direct joints and introduce least eccentricity in the joint. But their major disadvantages are: high residual stresses, necessity of edge preparation and proper aligning of the members in the field. Therefore, field butt joints are rarely used.

To minimise weld distortions and residual stresses, the heat input is minimised and hence the welding volume is minimised. This reduction in the volume of weld also reduces cost. Hence for thicker plates, double groove welds and U welds are generally used.

**7.1 Edge Preparation for Butt Weld**

Typical edge preparations are shown in Fig.12

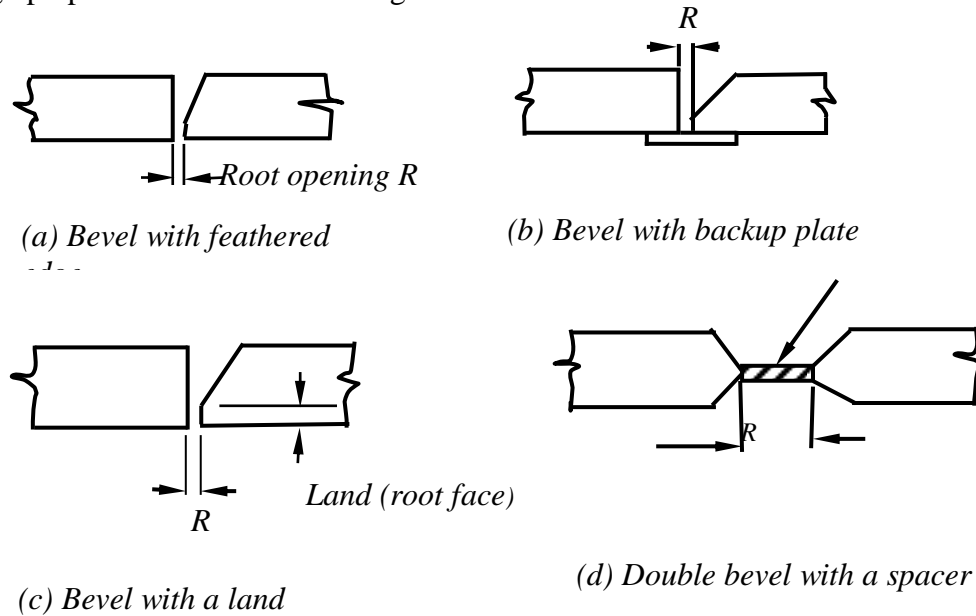

**Fig.12 Typical edge preparation for butt weld**

For a butt weld, the root opening,  $R$ , is the separation of the pieces being joined and is provided for the electrode to access the base of a joint. The smaller the root opening the greater the angle of the bevel. The depth by which the arc melts into the plate is called the depth of penetration [Fig.13 (a)]. Roughly, the penetration is about 1 mm per 100A and in manual welding the current is usually 150 – 200 A. Therefore, the mating edges of the

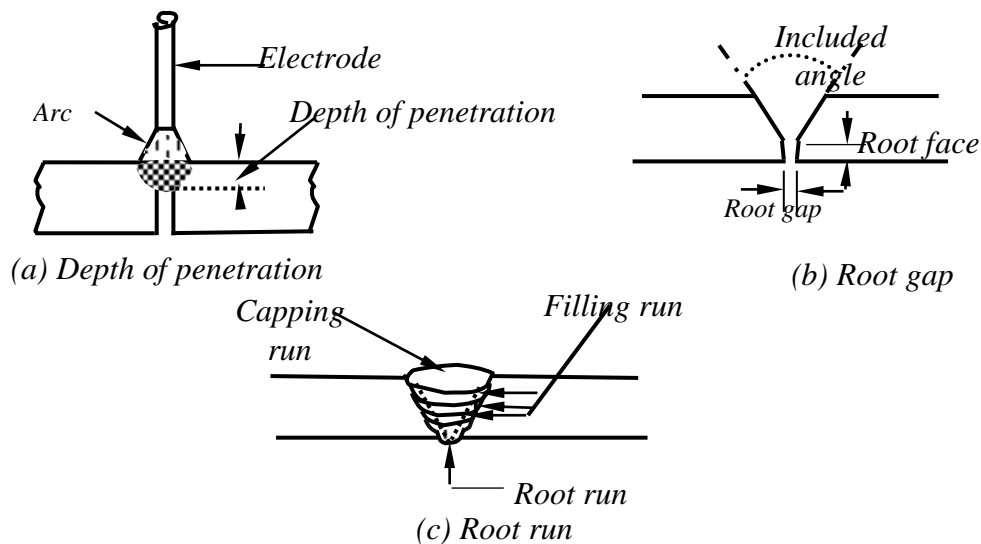

**Fig.13 Groove weld details**

plates must be cut back if through-thickness continuity is to be established. This groove is filled with the molten metal from the electrode. The first run that is deposited in the bottom of a groove is termed as the root run [Fig.13(c)]. For good penetration, the root faces must be melted. Simultaneously, the weld pool also must be controlled, preferably, by using a backing strip.

The choice of edge preparation depends on

1. Type of process
2. Position of welding
3. Access for arc and electrode
4. Volume of deposited weld metal
5. Cost of preparing edges
6. Shrinkage and distortion.

The square groove joint is used to connect thin material up to about 8 mm thick; for thicker material, single-vee groove and the double-vee groove welds have to be used.

## 8.0 FILLET WELDS

A typical fillet weld is shown in Fig.14 (a).

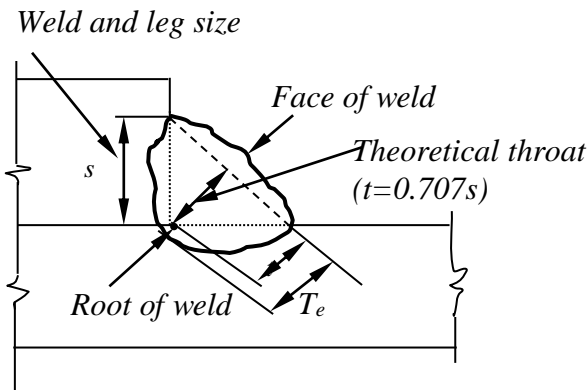

**Fig. 14 (a) Typical fillet weld**

Owing to their economy, ease of fabrication and adaptability, fillet welds are widely used. They require less precision in the fitting up because the plates being joined can be moved about more than the groove welds. Another advantage of fillet welds is that special preparation of edges, as required by groove welds, is not required. In a fillet weld the stress condition in the weld is quite different from that of the connected parts.

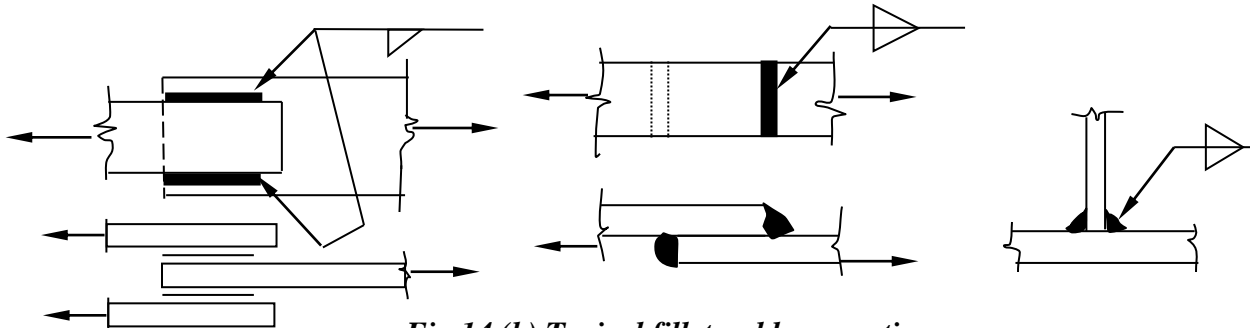

**Fig.14 (b) Typical fillet weld connections**

The size of a fillet weld is defined by the length of the two sides of the largest right triangle, which can be inscribed within the weld cross section. A major share of welds of this type has equal legs i.e. they form right isosceles triangle shown in Fig. 14(c). The typical fillet weld connections are shown in Fig. 14(b). The critical dimension of a fillet weld is its throat, the shortest distance from the root to the hypotenuse of the defining triangle shown in Fig. 14(c).

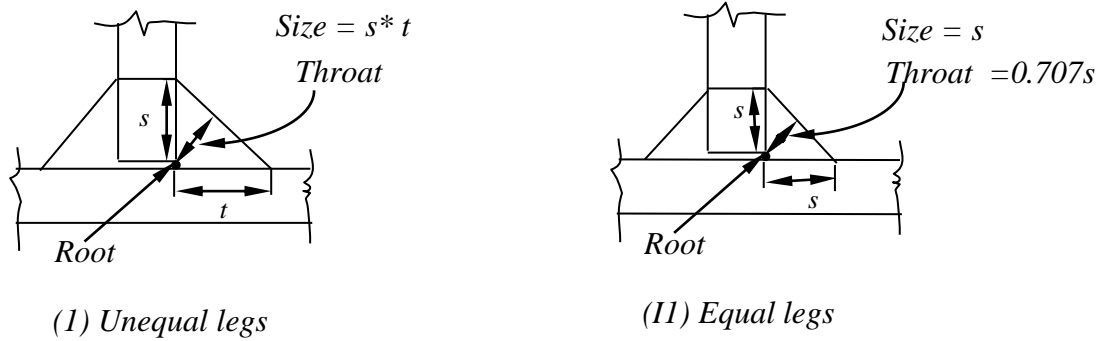

**Fig.14 (c) Unequal and Equal legs fillet welds**

The root of the weld is the point where the faces of the metallic members meet. The theoretical throat of a weld is the shortest distance from the root to the hypotenuse of the triangle. The throat area equals the theoretical throat distance times the length of the weld. Though a fillet weld is specified by defining the two sides of the inscribed triangle, its actual cross section will be quite complex. A fillet weld must penetrate the base metal and the interface of the weld is either concave or convex [Fig. 15(a)&(b)].

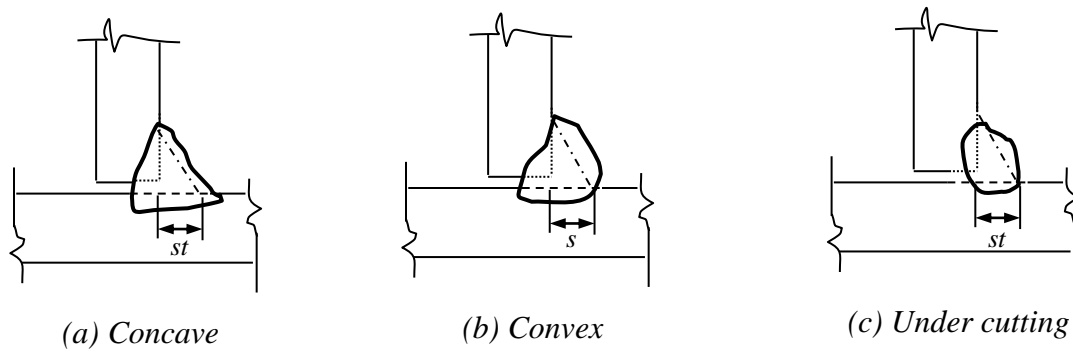

**Fig.15 Cross section of fillet weld**

The concave shape of free surface provides a smoother transition between the connected parts and hence causes less stress concentration than a convex surface. But it is more vulnerable to shrinkage and cracking than the convex surface and has a much reduced throat area to transfer stresses. On the other hand, convex shapes provide extra weld metal or reinforcement for the throat. But while making a convex surface there is always the possibility of causing undercut at the edges, which undermines the strength of the joint [Fig. 15(c)]. The stress concentration is higher in convex welds than in concave



welds. It is generally recommended that for statically loaded structures, a slightly convex shape is preferable, while for fatigue – prone structures, concave surface is desirable.

Large welds are invariably made up of a number of layers or passes. For reasons of economy, it is desirable to choose weld sizes that can be made in a single pass. Large welds can be made in a single pass by an automatic machine, though manually, 8 mm fillet is the largest single-pass layer.

## 9.0 FACTORS AFFECTING THE QUALITY OF WELDED CONNECTIONS

A good weld is obtained from a combination of many factors, from the design of the weld to the welding operation. Even a well-designed weld may not give a strong connection if it is not properly made. Therefore, a structural engineer must be aware of the various factors that affect the quality of the weld. Some of those factors are explained in the following.

### 9.1 Proper Electrodes, Welding Apparatus and Procedures

Depending on the grade of steel and its thickness, appropriate electrode with suitable diameter has to be selected. The size of the electrode is chosen based on the size of the weld to be made and also on the output of the welding apparatus. It is important that the welding apparatus is capable of delivering enough current for the size of the electrode. Since the output of welding apparatus can be controlled within limits, an electrode of small size may also be used.

In metal – arc welding, the metal is deposited by electromagnetic shield and not by gravity. Therefore the welder is not limited to horizontal or flat welding positions. It is better to avoid overhead welding as the controlling of the process is very difficult and requires a highly skilled welder. In the field, it may not be possible to avoid overhead welding fully; so adequate care must be taken in specifying and making such a weld.

### 9.2 Welding Sequence

Sequence of welding plays a key role in obtaining a satisfactory welded fabrication. The smallest weld size that can fulfil the requirements is the hallmark of a good weld designer. It is always advisable to weld away from a point of restraint; welding of a joint should start from the centerline and proceed towards the free end. The principle of doubling –up method is employed for a single run fillet weld on either side of the vertical member (Fig. 16).

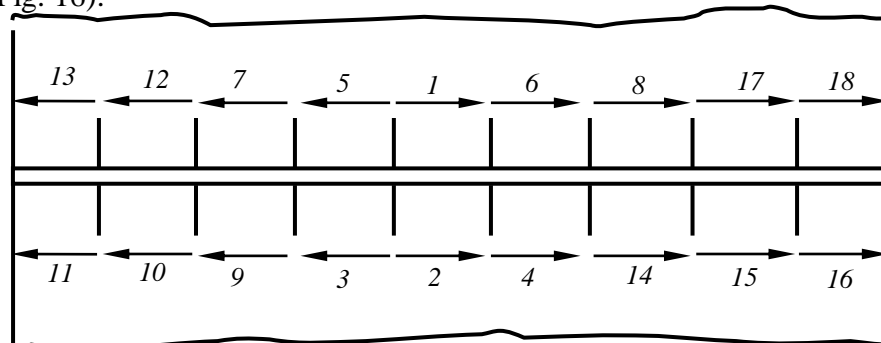

*Fig.16 Sequence of welding fillet welds on either side of a vertical member (doubling-up method)*

This eliminates transverse angular distortion of a Tee joint. The planned wandering method of welding, shown in Fig.17 is used for butt welded joints with two operators.

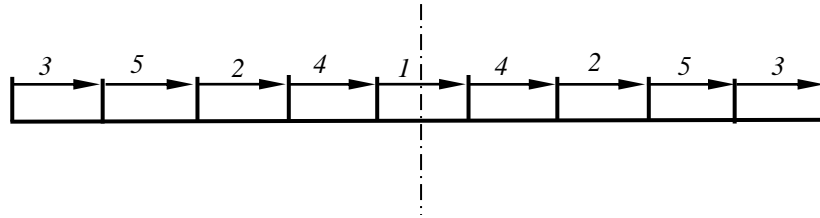

**Fig.17 Planned Wandering Method for Welding Long Butt Joint with Two Operators**

Another alternative is the stepback method (Fig. 18) in which the welding is carried out in an evenly balanced manner about the centerline of a joint.

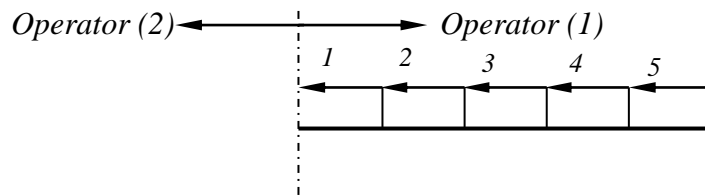

**Fig.18 Step Back Method for Welding Long Joint With Two Operators**

## 10.0 RESIDUAL STRESSES AND WELD DISTORTION

### 10.1 Residual Stresses

In any fusion welding process, the first step is to heat the surfaces to be joined. This heating process is fast and restricted to a narrow portion, where the joint is to be made. The region, which is heated, expands, whereas the rest of the metal resists the expansion. As a consequence compressive stresses are induced near the joint during the heating. After the welding operation is over, the region of intense heating starts cooling. The contraction, which should result, is prevented because the two separate pieces, which were originally free to expand, have now been joined and are not free to contract. Further, the temperature distribution of the weldment would be vastly different from that of the two separate pieces. The net result is that tensile stresses are developed near the weld and compressive stresses away from it. This is shown in Fig. 19. Thus in any welding process involving rapid heating and cooling, residual stresses would always be present. The amount of the residual stresses would vary depending up on the joint restraint, geometry, thermal properties of the material, welding process employed etc. If the parts to be joined are free to expand and contract then the residual stresses would be minimum. However the presence of external restraints would prevent free expansion and contraction resulting in large levels of stresses. In general, residual stresses are increased when increased number of passes is made. The thermal expansion coefficient and thermal conductivity influence the residual stress level. Poor thermal conductivity and high

thermal expansion coefficient would significantly increase the residual stresses in a weldment.

Yield strength of material is the upper limit for the residual stress. If the stresses exceed the yield strength, which is normal in welding, the material yields leading to permanent deformation or change of shape. This permanent deformation caused by stresses resulting from thermal cycles is called distortion. This is explained in the next section.

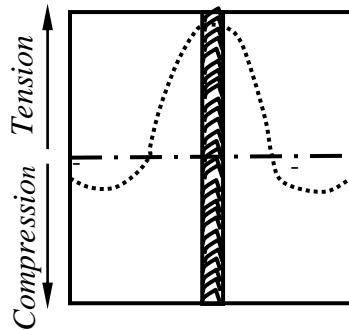

*Fig.19 Longitudinal residual stress due to weld*

## 10.2 Distortion in Weldments

In a welding operation, due to heating and cooling of the weld metal and base metal regions near the weld, thermal strains are induced in them. The strains thus produced may be accompanied by plasticity. The stresses due to these strains combine and react to produce internal forces causing bending, buckling and rotation. The displacement arising out of these forces are called distortion.

Three basic dimensional changes that occur during the welding process cause distortion in fabricated structures:

1. Transverse shrinkage perpendicular to the weld line.
2. Longitudinal shrinkage parallel to the weld line.
3. Angular distortion (rotation around the weld line).

These dimensional changes are classified according to their appearance into the following

- (a) Transverse shrinkage: the shrinkage is perpendicular to the weld line
- (b) Angular change: Non-uniform thermal distortion in the thicker direction causes the angular change close to the weld line, otherwise known as transverse distortion.
- (c) Rotational distortion: angular distortion in the plane of the plate due to thermal expansion.
- (d) Longitudinal shrinkage: shrinkage in the direction of the weld line.

- (e) Longitudinal bending distortion: distortion in plane through the weld line and perpendicular to the plate.  
 (f) Buckling distortion: thermal compressive stresses cause instability in thin plates.

Some of the above are illustrated in Fig. 20.

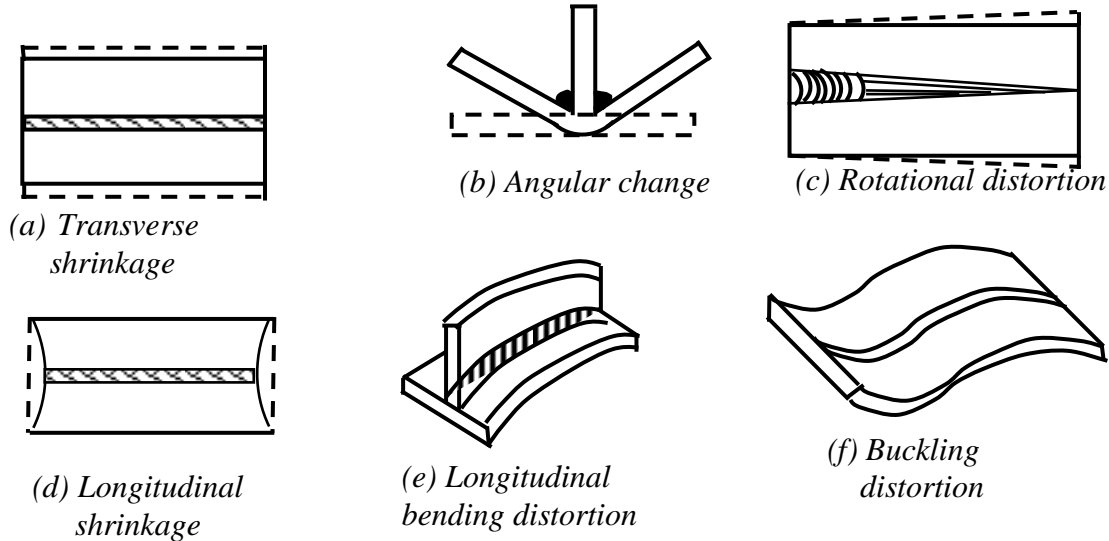

**Fig. 20 Weld distortion**

The three main approaches to overcome the problems of distortion are:

- (1) Minimising the distortion using carefully controlled welding procedures.
- (2) Developing standards for acceptable distortion limits.
- (3) Using appropriate techniques to remove distortion.

A judicious combination of the above approaches would result in making distortion free welds:

The first approach is to use a welding process that would produce no shrinkage or distortion. However there is no process that would completely eliminate distortion. Close attention should be paid to factors such as welding sequence, degree of restraint, welding condition, joint details, the preheat etc. that contribute to weld distortion.

As distortion is unavoidable, it would be prudent to set up rational standards for acceptable distortion, considering the reliability, economic value and fabrication cost of the structure.

If distortion exceeds the acceptable limits, then the distortion has to be removed with minimum damage to the structure. Distortion may occur even during the service due to overloading or impact. Some of the techniques used for removal of distortion are: (a) flame heating at selected spots and cooling with water, and (b) hammering while it is being heated or by applying a local force to cause counter distortions.

## 11.0 WELD SYMBOLS







Welding will become a powerful engineering tool when the information required for welding is provided by the designers to the operators. The information concerning type, size, position, welding process etc. of the welds in welded joints is conveyed by standard symbols in drawings. Usage of standard symbols by all designers and fabricators would help avoid confusion and misunderstanding. The symbolic representation gives clearly all necessary indications regarding the specific weld to be achieved.



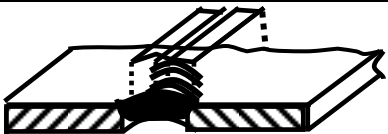





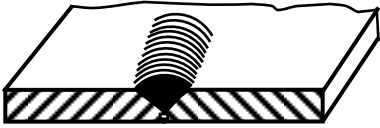
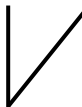



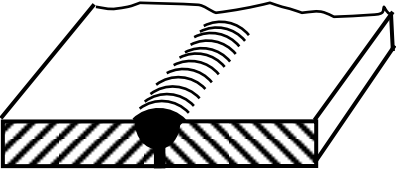

The symbolic representation includes elementary symbols along with a) supplementary symbol, b) a means of showing dimensions, or c) some complementary indications. IS: 813-1986, "Scheme Of Symbols for Welding" gives all the details of weld representation in drawings.

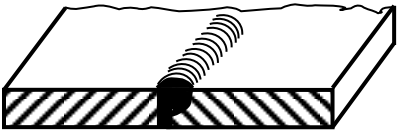
Elementary symbols represent the various categories of the weld and look similar to the shape of the weld to be made. Combination of elementary symbols may also be used, when required. Elementary symbols are shown in Table 1.

Supplementary symbols characterise the external surface of the weld and they complete the elementary symbols. Supplementary symbols are shown in Table 2. Combinations of elementary and supplementary symbols are given in Table 3. The weld locations are defined by specifying, a) position of the arrow line, b) position of the reference line, and c) the position of the symbol. More details of weld representation may be obtained from IS 813-1986.

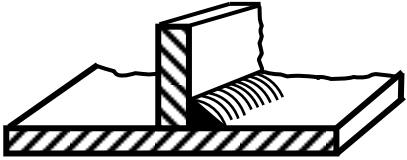
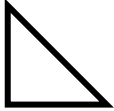
*Table 1. Elementary Symbols*

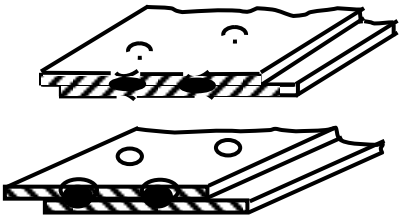
Illustration(Fig.)	Symbol	Description
		Butt weld between plates with raised edges*(the raised edges being melted down completely)
		Square butt weld
		Single-V butt weld
		Single-bevel butt weld

		<p>Single – V butt weld with broad root face</p>
		<p>Single – bevel butt weld with broad root face</p>
		<p>Single – U butt weld (parallel or sloping sides)</p>
		<p>Single – J butt joint</p>
		<p>Backing run; back or backing weld</p>
		<p>Fillet weld</p>
		<p>Plug weld; plug or slot weld</p>
		<p>Spot weld</p>

		<p>Seam weld</p>
--	--	------------------

*Table 2. Supplementary Symbols*

		<p>Flat (flush) single – V butt weld</p>
		<p>Convex double – V butt weld</p>
		<p>Concave fillet weld</p>
		<p>Flat (flush) single – V butt with flat (flush) backing run</p>

*Table 3 Combination of Elementary and Supplementary Symbols*

Shape Of Weld Surface	symbol
(a) flat (usually finished flush)	
(b) convex	
(c)concave	

**11.1 Position of symbols in drawings**

Apart from the symbols as covered earlier, the method of representation (Fig. 21) also include the following:

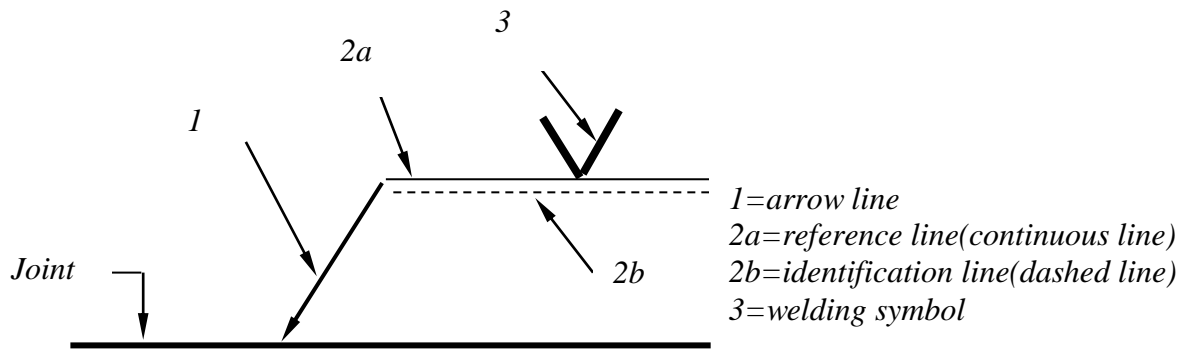

**Fig. 21 Method of Representation**

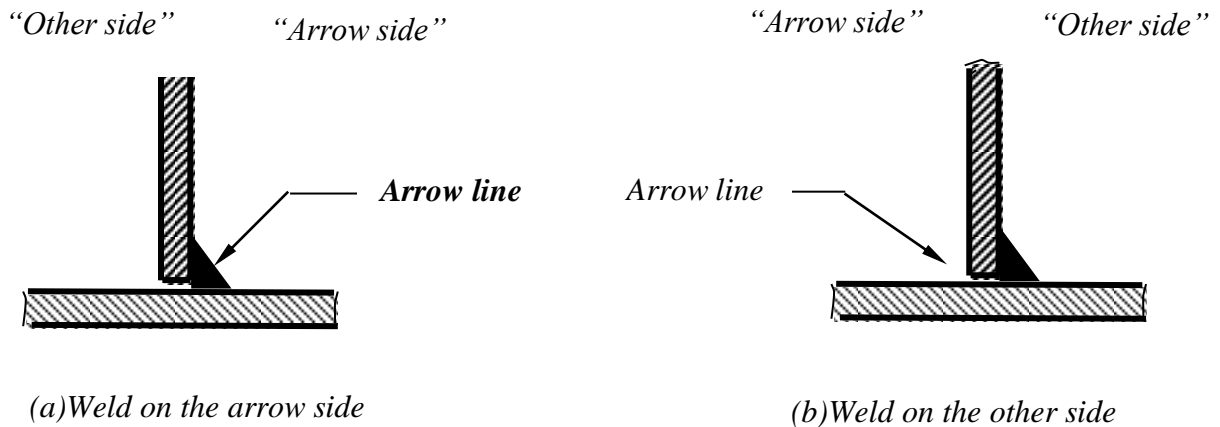

**Fig. 22 T-Joint with one fillet weld**

- An arrow line for each joint
- A dual reference line, consisting of two parallel lines, one continuous and the other dashed.
- A certain number of dimensions and conventional signs

The location of welds is classified on the drawings by specifying:

- Position of the arrow line
- Position of the reference line and
- The position of the symbol

The relation between arrow line and the joint, shown in Fig. 22 (a, b) explain the meaning of the terms ‘arrow side’ of the joint and ‘other side’ of the joint. The position of arrow line with respect to the weld has no special significance. The arrow line joins one end of the continuous reference line such that it forms an angle with it and shall be completed by



an arrowhead or a dot. The reference line is a straight line drawn parallel to the bottom edge of the drawing.

The symbol is placed either above or beneath the reference line. The symbol is placed on the continuous side of the reference line if the weld is on the other side of the joint; the symbol is placed on the dashed line side

## 12.0 DEFECTS IN WELDS

If good welding methods and procedures are not followed a number of defects may be developed causing discontinuities within the weld. Some of the important defects are described in the following.

### 12.1 Incomplete fusion

Complete fusion may not take place, if the mating surfaces are not properly cleaned of all coatings such as mill scales, slag, oxides etc. This defect may also be caused by insufficient current, because of which the base metal does not melt properly. Rapid rate of welding also leads to improper fusion. The different types of incomplete fusion are shown in Fig.23.

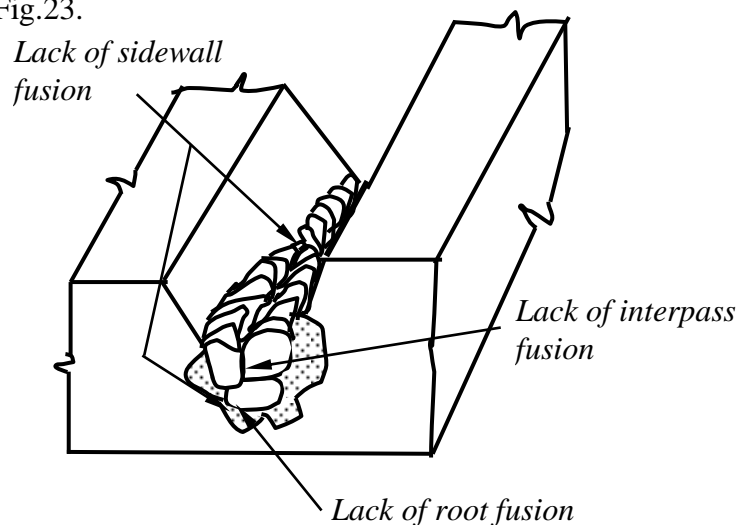

**Fig.23 Lack of fusion (or) incomplete fusion**

### 12.2 Porosity

Porosity is formed when a number of gas pockets or voids are trapped during the cooling process. Use of excessively high current and longer arc length are the reasons for this type of defect. Porosity may occur in two ways: Either dispersed through the weld or as a large pocket at the root near to the backup plate in a groove weld. Improper welding procedures and careless use of backup plates result in porosity in groove welds.

### 12.3 Inadequate penetration

In certain instances, partial penetration may be adequate. However when the weld penetration is less than that specified, it is termed as inadequate penetration. This type of

defect, primarily occurring in groove welds, is due to insufficient groove angles, very large electrodes, inadequate weld current, larger welding rates, or insufficient gaps at the root of welds. The defect can be avoided by means of backup plates. Inadequate penetration is shown in Fig.24.

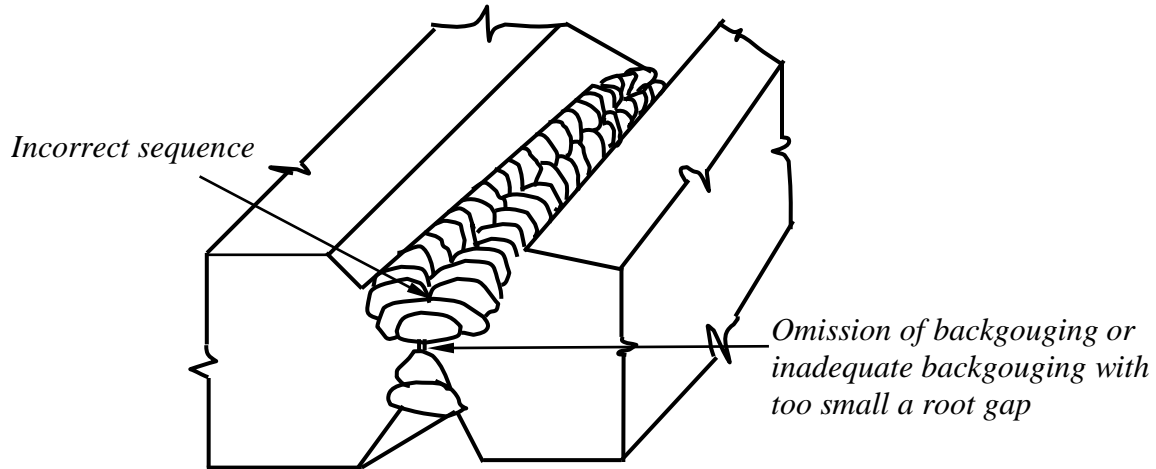

**Fig.24 Lack of penetration**

#### 12.4 Under cutting

This type of defect is formed due to the use of excessive current or an excessively long arc. A portion of the metal is burnt away reducing the thickness of the joint at the edge of the weld. The defect is detected easily by visual inspection and repaired easily by depositing additional weld material. Examples of under cutting are shown in Fig.25.

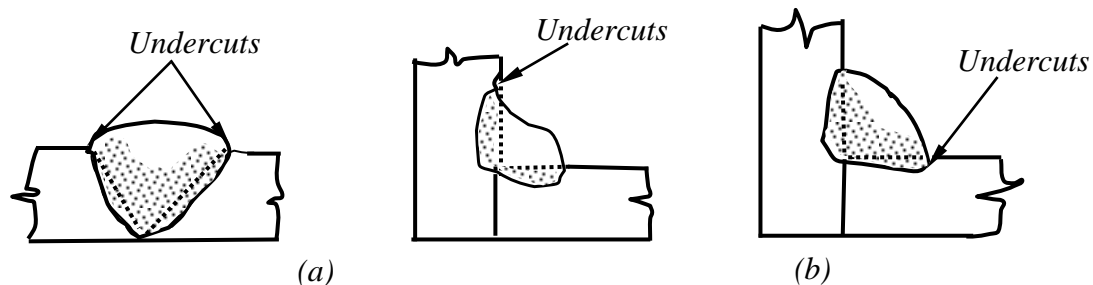
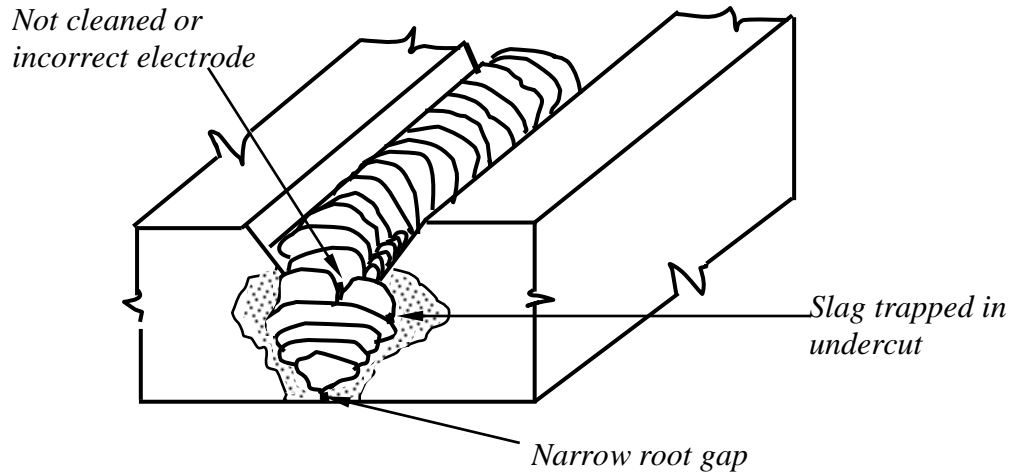

**Fig. 25 Typical examples of undercut defect. (a) Wide and curved, (b) Narrow and crack like**

#### 12.5 Slag inclusion

Slag is formed in the welding process due to the chemical reaction of the melted electrode coating. It normally consists of metal oxides and other compounds. Since it has less density than the molten weld metal the slag usually floats on the surface. On cooling, this is removed by the welder. But, if the cooling is rapid, the slag may get trapped before

it can rise to the surface. When several passes of weld are made to achieve the desired weld size, the slag that forms between each process must be removed completely. The main reason for slag inclusion is due to the failure to remove the slag fully between runs. Overhead welds are also susceptible to slag inclusion and hence adequate care should be taken. Slag inclusion is shown in Fig. 26.



**Fig.26 Slag inclusion**

## 12.6 Cracks

Cracks are by far the most severe form of weld defects. Cracks occur in the form of breaks in the weld metal. They are the result of internal stresses and form either longitudinally or transversely to the line of weld. Cracks may extend from the welded metal into the base metal. They may also be completely in the base metal very near to the weld in HAZ.

Cracks may occur either in the hot or cold form. Hot cracks are formed as the weld begins to solidify. Uniform heating and slower cooling will prevent hot cracks. Cold cracks, which occur at room temperature, run parallel to but under the weld in the base metal. Using certain special electrodes and proper preheating and post heating, cold cracking can be reduced.

## 12.7 Lamellar Tearing

Lamellar tearing is a type of cracking that occurs in the base metal beneath the weld. It is caused by the combined effects of high, localised stresses from weld contraction and poor through - thickness ductility in the steel. The tearing is started by the separation of the interface between inclusions and metal (also known as delamination) or by fracture of an inclusion itself. The cracks grown by the joining of the delamination in the same plane or by the shear steps, which join the cracks in different planes. This results in a characteristic step-like appearance for lamellar tearing. Lamellar tear is shown in Fig. 27.

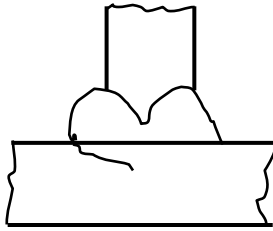

*Fig. 27 Lamellar tear*

The influencing factors in lamellar tearing are:

- Amount of Non-metallic inclusion and their orientation.
- Magnitude of induced normal stresses normal to the plate surface.

The presence of inclusions reduces the ductility of steel in the through - thickness direction because the bond between the inclusion and steel is much weaker than steel itself. The magnitude of stresses induced depends on the joint design, the imposed degree of restraint on the joint, plate thickness, size of the weld and orientation of the weld. Restrained corner or T-joints are most susceptible to lamellar tearing, as the through - thickness contraction stresses are high. Butt welds rarely experience lamellar tear. Thick plate, high restraint (rigid clamping) and large weld beads all contribute to residual stresses and the chances of tearing. Hydrogen also increases the vulnerability to lamellar tearing. Hence preheat is beneficial to reduce the tendency to lamellar tearing. It is also beneficial to use low hydrogen consumables.

The following precautions may be taken to reduce lamellar tearing.

- Using plate material with improved through – thickness properties.
- Designing the joint with minimum through-thickness stresses.
- Using lower strength welding consumables.
- In special cases, the plate may be ground to a level below where lamellar tearing is expected. The area can be provided with weld metal and the attachment weld can be made.

## **13.0 WELD DEFECT ACCEPTANCE LEVELS**

### **13.1 General**

Weld defects acceptance levels are closely related to the available methods of Non - Destructive Examination (NDE).

Previously, radiography was the best technique available for inspection of welds. Then, acceptance conditions were in terms of maximum slag inclusion and porosity levels. Presence of cracks was not acceptable and repairs were absolutely essential. The use of ultrasonic technique has made it possible to detect smaller cracks, when compared to radiography. Thus, welds, which passed radiographic inspection, required extensive repair by the new method of inspection. The method of fracture mechanics has made it possible to assess the potential of cracks to cause serious damage and thus to come up

with tolerable defect sizes. Slag inclusion and porosity may not be particularly deleterious defects unless fatigue type of loading is anticipated. By fracture mechanics approach, it has been established that the cracks detected by the ultrasonic methods are far smaller than those that affect the safety of the structure. Uses of fracture mechanics method has proved that tolerable defect sizes are large. This would result in cost saving in terms of repair and reduce the level of NDE inspection.

### 13.2 Accepted Criteria for Welded Joints

In general the following weld defects detected during inspection are acceptable for structures.

- For joints welded from both the sides, incomplete penetration with thickness up to 5% of the parent metal thickness, but not exceeding 2 mm and the length more than 500 mm can be accepted. The aggregate length of flaw shall not be more than 200 mm per meter length of the joint. Incomplete penetration and cracks are not allowed at or near the end or beginning of a joint.
- For joints welded from one side with out backing strip, incomplete penetration with thickness up to 15% of parent metal thickness but not exceeding 3 mm at the root is allowed.
- Slag inclusion located along the weld as a chain or unbroken line is allowed if their aggregate length does not exceed 200 mm per meter of weld length. Size of the slag may also be considered.
- Total of isolated gas pores and slag inclusion shall not exceed 5 in number per square centimetre of the weld.
- Total of incomplete penetration, slag inclusion on pores located separately or as a chain shall not exceed 10% of metal thickness but not greater than 2 mm when welding is done from both the sides and 15% of metal thickness, but not greater than 3 mm when welding is done from one side.
- For metal thickness up to 10 mm, undercuts shall not be more than 0.5 mm. For metal thickness more than 10 mm, undercuts shall not be greater than 1 mm.

Incomplete weld, molten metal flow, pits and cracks shall not be allowed.

## 14.0 WELDING INSPECTION

There are essentially three steps to be followed to ensure good welding; they are:

- 1 Establishing good welding procedures
- 2 Use of pre-qualified welders
- 3 Availability of competent inspectors in shop and field

It is essential that welded joints are thoroughly examined and defects are detected so that any possible distress could be averted. There are several non-destructive testing methods to check the quality of welds. They are explained in the following.

### **14.1 Visual inspection**

Visual inspection by a competent person will give a good indication of the quality of welds; but may not be able to gauge the sub surface condition of the welds. An experienced welder, by visual inspection, would be able to know whether satisfactory fusion and penetration are obtained. He will be able to recognise good welds by their shape, size and general appearance. In a good weld, the metal should be nearly its original colour after it has cooled. In case of over heating, it will give a rusty appearance. There are several scales and gauges to check the size and shape of welds.

Methods of determining the internal soundness of a weld are described in the following section.

### **14.2 Liquid Penetrants**

In this method, a type of dye is spread over the weld surface. This dye penetrates into the surface cracks of the weld. After the penetration of the dye, any excess material is removed and a powdery developer is sprayed to draw the dye out of the cracks. Then, the outline of the cracks can be seen with naked eye. In some cases, fluorescent dyes are used for improved visibility of the cracks.

### **14.3 Magnetic Particles**

The weld that is inspected is 'magnetised' electrically. Cracks, which are present at or near the surface, would cause North and South poles to form on each side of the cracks. Dry iron filings are then kept on the weld. They form patterns when they cling to cracks. From the patterns, the location of cracks, their size and shapes are established.

### **14.4 Ultrasonic Testing**

By means of the ultrasonic equipment, sound waves are sent through one side of the material and they are reflected from the opposite side. These reflections are indicated in a cathode ray tube. Any defect in the weld will alter the time of the sound transmission. By the help of the picture in the tube, flaws can be detected and their severity can be judged.

### **14.5 Radiography**

This is an expensive method and can be used to check the welds in important structures. Portable X-ray machines along with radium or radioactive cobalt would give excellent pictures. This method is reliable for butt welds, but is not satisfactory for fillet welds due to difficulty in interpreting pictures. Another drawback of the method is the radioactive danger. Much care has to be taken while carrying out this inspection to protect the workers on the job.

A properly welded connection is usually much stronger (1.5 to 2 times) than the strength of the members being connected. The reasons for the extra strength are: electrode wire is made up of premium steel, the metal is melted electrically and the cooling rate is rapid. Due to these factors, the weld strength is always higher than required by the design.

## 15.0 CONCLUSION

In this chapter, fundamentals of welding, details of the various welding processes, types of welds, common weld defects and weld inspection have been covered. Advantages of welding over other forms of connection such as bolting and riveting are explained in detail. Design of various types of welded connections in steel structures is explained in next chapter.

## 16.0 REFERENCES

1. Morrow H.W., “Elements of Steel Design””, Prentice Hall, Inc. / Englewood Cliffs, New Jersey-1987.
2. Dowling P.J., Knowles P.R. and Owens G.W., Structural Steel Design, The Steel Construction Institute, Butterworths, London, 1988.
3. McCormac J.C., “Structural Steel Design”(Third Edition), Harper and Row, Publishers, New York, 1981.
4. IS: 813 – 1986. “Scheme Of Symbols For Welding”, Bureau of Indian Standards New Delhi.