

STEEL-CONCRETE COMPOSITE COLUMNS-I

1.0 INTRODUCTION

A steel-concrete composite column is a compression member, comprising either a concrete encased hot-rolled steel section or a concrete filled tubular section of hot-rolled steel and is generally used as a load-bearing member in a composite framed structure. Typical cross-sections of composite columns with fully and partially concrete encased steel sections are illustrated in Fig. 1. Fig. 2 shows three typical cross-sections of concrete filled tubular sections. Note that there is no requirement to provide additional reinforcing steel for composite concrete filled tubular sections, except for requirements of fire resistance where appropriate.

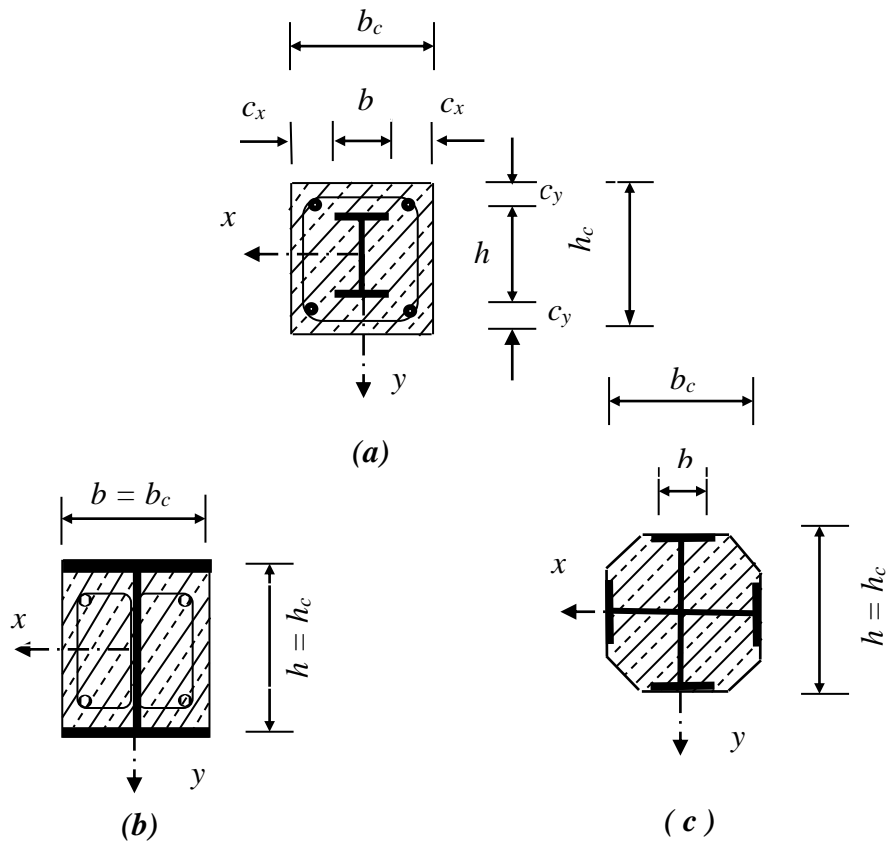

Fig. 1: Typical cross - sections of fully and partially concrete encased columns

© Copyright reserved

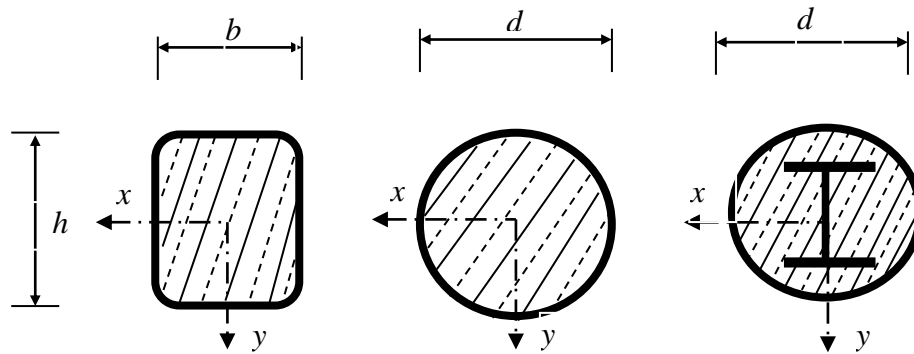

Fig. 2: Typical cross-sections of concrete filled tubular sections

In a composite column both the steel and concrete would resist the external loading by interacting together by bond and friction. Supplementary reinforcement in the concrete encasement prevents excessive spalling of concrete both under normal load and fire conditions.

In composite construction, the bare steel sections support the initial construction loads, including the weight of structure during construction. Concrete is later cast around the steel section, or filled inside the tubular sections. The concrete and steel are combined in such a fashion that the advantages of both the materials are utilised effectively in composite column. The lighter weight and higher strength of steel permit the use of smaller and lighter foundations. The subsequent concrete addition enables the building frame to easily limit the sway and lateral deflections.

With the use of composite columns along with composite decking and composite beams it is possible to erect high rise structures in an extremely efficient manner. There is quite a vertical spread of construction activity carried out simultaneously at any one time, with numerous trades working simultaneously. For example

- One group of workers will be erecting the steel beams and columns for one or two storeys at the top of frame.
- Two or three storeys below, another group of workers will be fixing the metal decking for the floors.
- A few storeys below, another group will be concreting the floors.
- As we go down the building, another group will be tying the column reinforcing bars in cages.
- Yet another group below them will be fixing the formwork, placing the concrete into the column moulds etc.

The **advantages** of composite columns are:

- increased strength for a given cross sectional dimension.
- increased stiffness, leading to reduced slenderness and increased buckling resistance.
- good fire resistance in the case of concrete encased columns.
- corrosion protection in encased columns.

- significant economic advantages over either pure structural steel or reinforced concrete alternatives.
- identical cross sections with different load and moment resistances can be produced by varying steel thickness, the concrete strength and reinforcement. This allows the outer dimensions of a column to be held constant over a number of floors in a building, thus simplifying the construction and architectural detailing.
- erection of high rise building in an extremely efficient manner.
- formwork is not required for concrete filled tubular sections.

2.0 MATERIALS

2.1 Structural Steel

All structural steels used shall, before fabrication conform to *IS: 1977-1975*, *IS: 2062-1992*, and *IS: 8500-1977* as appropriate. Some of the structural steel grade commonly used in construction as per *IS: 961-1975* and *IS: 1977-1975* are given in Table 1.

Table1(a): Yield strength f_y of steel sections

Nominal steel grade	Nominal thickness/diameter (mm)	Yield stress, f_y (MPa)
Fe 570-HT	$t < 6$	350
	$6 \leq t \leq 28$	350
	$28 < t \leq 45$	340
Fe 540W-HT	$t < 6$	350
	$6 \leq t \leq 16$	350
	$16 < t \leq 32$	340
Fe 410-O (not subjected to dynamic loading other than wind)	$t < 6$	250
	$6 \leq t \leq 20$	250
	$20 < t \leq 40$	240

Table1(b): Yield strength f_y of steel sections as per IS 2062:1992

Nominal steel grade	Nominal thickness/diameter (mm)	Yield stress, f_y (MPa)
Fe 410W A	< 20	250
	20 - 40	240
	> 40	230
Fe 410W B	< 20	250
	20 - 40	240
	> 40	230
Fe 410W C	< 20	250
	20 - 40	240
	> 40	230

2.2 Concrete

Concrete strengths are specified in terms of the characteristic cube strengths, $(f_{ck})_{cu}$, measured at 28 days. Table 2 gives the properties of different grades of concrete according to IS: 456-2000 and the corresponding EC4 values.

Table 2: Properties of concrete

Grade Designation	M25	M30	M35	M40
$(f_{ck})_{cu} (N/mm^2)$	25	30	35	40
$(f_{ck})_{cy} (N/mm^2)$	20	25	28	32
$f_{cm} (N/mm^2)$	2.2	2.6	2.8	3.3
$E_{cm} = 5700 \sqrt{(f_{ck})_{cu}} (N/mm^2)$	28500	31220	33720	36050

where, $(f_{ck})_{cu}$ characteristic compressive (cube) strength of concrete
 $(f_{ck})_{cy}$ characteristic compressive (cylinder) strength of concrete, given by 0.8 times 28 days cube strength of concrete according to EC4
 f_{cm} mean tensile strength of concrete

For lightweight concrete, the E_{cm} values are obtained by multiplying the values from Table 2 by $\rho/2400$, where ρ is the unit mass (kg/m^3)

2.3 Reinforcing Steel

Steel grades commonly used in construction are given in Table 3. It should be noted that although the ductility of reinforcing bars has a significant effect on the behaviour of continuous composite beams, this property has little effect on the design of composite columns. Concrete filled tubular sections may be used without any reinforcement except for reasons of fire resistance, where appropriate.

Table 3: Characteristic strengths of reinforcing steel

Type of steel	Indian Standard	Nominal size (mm)	Yield Stress, $f_{sk} (N/mm^2)$
Mild steel Grade I (plain bars)	IS:432(Part1)-1982	$d \leq 20$	250
		$20 < d \leq 50$	240
Mild steel Grade II (plain bars)	IS:432(Part1)-1982	$d \leq 20$	225
		$20 < d \leq 50$	215
Medium tensile steel (plain bars)	IS:432(Part1)-1982	$d \leq 16$	540
		$16 < d \leq 32$	540
		$32 < d \leq 50$	510
Medium tensile steel (Hot-rolled deformed bars and Cold-twisted deformed bars)	IS:1786-1985	for bars of all sizes	415
			500
			550

Note: This chapter is confined to steel concrete composite columns made up of hot rolled steel sections having yield strengths within the range 250 N/mm^2 to 350 N/mm^2 and reinforcement with steel rods of 415 or 500 N/mm^2 . This limitation is considered necessary at the present time on account of the lower ductility of steels having higher yield strengths.

2.4 Partial safety factors

2.4.1 Partial safety factor γ_f for loads - The suggested partial safety factor γ_f for different load combinations is given below in Table 4.

Table 4 : Partial safety factors (According to proposed revisions to IS 800)

Loading	γ_f		
	DL	LL	WL
Dead Load (unfavourable effects)	1.35	-	-
Dead load restraining uplift or overturning	1.0	-	-
Imposed Load + Dead Load	1.35	1.5	-
Dead Load + Wind Load	1.35	-	1.5
Dead Load + Imposed Load + wind Load (Major Load)	1.35	1.05	1.5
Dead Load + Imposed Load (Major Load) + wind Load	1.35	1.5	1.05

2.4.2 Partial safety factor for materials

The partial safety factor γ_m for structural steel, concrete and reinforcing steel is given in Table5.

Table 5: Partial safety factor for materials

Material	γ_m^*
Steel Section	1.15
Concrete	1.5
Reinforcement	1.15

*IS: 11384-1985 Code for composite construction has prescribed $\gamma_m = 1.15$ for structural steel. (By contrast, EC4 has prescribed $\gamma_m = 1.10$ for structural steel).

3.0 COMPOSITE COLUMN DESIGN

3.1 General

As in other structural components, a composite column must also be designed for the Ultimate Limit State. For structural adequacy, the internal forces and moments resulting from the most unfavourable load combination should not exceed the *design resistance* of

the composite cross-sections. While local buckling of the steel sections may be eliminated, the reduction in the compression resistance of the composite column due to overall buckling should definitely be allowed for, together with the effects of residual stresses and initial imperfections. Moreover, the second order effects in slender columns as well as the effect of creep and shrinkage of concrete under long term loading must be considered, if they are significant. The reduction in flexural stiffness due to cracking of the concrete in the tension area should also be considered.

3.2 Method of Design

At present, there is no Indian Standard covering Composite Columns. The method of design suggested in this chapter largely follows *EC4*, which incorporates the latest research on composite construction. Isolated symmetric columns having uniform cross sections in braced or non-sway frames may be designed by the *Simplified design method* described in the next section. This method also adopts the European buckling curves for steel columns as the basis of column design. It is formulated in such a way that only hand calculation is required in practical design. This method cannot be applied to sway columns.

When a sufficiently stiff frame is subjected to in-plane horizontal forces, the additional internal forces and moments due to the consequent horizontal displacement of its nodes can be neglected, and the frame is classed as “non-sway”.

3.3 Fire resistance

Due to the thermal mass of concrete, composite columns always possess a higher fire resistance than corresponding steel columns. (It may be recalled that composite columns were actually developed for their inherent high fire resistance). Composite columns are usually designed in the normal or ‘cool’ state and then checked under fire conditions. Additional reinforcement is sometimes required to achieve the target fire resistance. Some general rules on the structural performance of composite columns in fire are summarised as follows:

- The fire resistance of composite columns with fully concrete encased steel sections may be treated in the same way as reinforced concrete columns. The steel is insulated by an appropriate concrete cover and light reinforcement is also required in order to maintain the integrity of the concrete cover. In such cases, two-hour fire resistance can usually be achieved with the minimum concrete cover of *40 mm*.
- For composite columns with partially concrete encased steel sections, the structural performance of the columns is very different in fire, as the flanges of the steel sections are exposed and less concrete acts as a ‘heat shield’. In general, a fire resistance of up to one hour can be achieved if the strength of concrete is neglected in normal design. Additional reinforcement is often required to achieve more than one-hour fire resistance.

- For concrete filled tubular sections subjected to fire, the steel sections are exposed to direct heating while the concrete core behaves as ‘heat sink’. In general, sufficient redistribution of stress occurs between the hot steel sections and the relatively cool concrete core, so that a fire resistance of one hour can usually be achieved.

For longer periods of fire resistance, additional reinforcement is required, which is not provided in normal design. Steel fibre reinforcement is also effective in improving the fire resistance of a concrete filled column. It is also a practice in India to wrap the column with ferrocement to increase the fire rating

4.0 PROPOSED DESIGN METHOD

The simplified method is formulated for prismatic composite columns with doubly symmetrical cross-sections. The calculations of various design parameters are covered and the checks for structural adequacy of a composite column under applied loads are presented below.

4.1 Resistance of cross-section to compression

The plastic compression resistance of a composite cross-section represents the maximum load that can be applied to a short composite column. Concrete filled circular tubular sections exhibit enhanced resistance due to the tri-axial confinement effects. Fully or partially concrete encased steel sections and concrete filled rectangular tubular sections do not achieve such enhancement.

4.1.1 Encased steel sections and concrete filled rectangular/square tubular sections:-

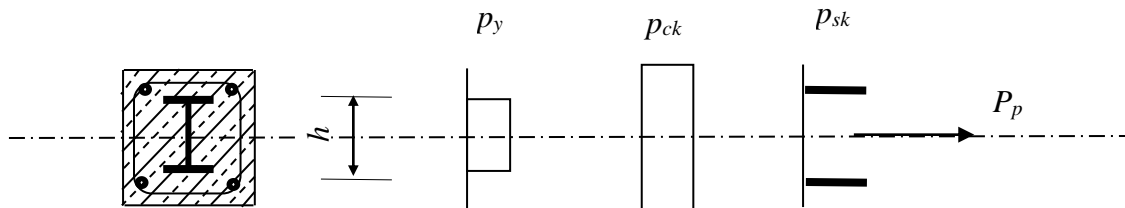

Fig. 3 Stress distribution of the plastic resistance to compression of an encased I section

The plastic resistance of an encased steel section or concrete filled rectangular or square section (i.e. the so-called “squash load”) is given by the sum of the resistances of the components as follows:

$$P_p = A_a \cdot f_y / \gamma_a + \alpha_c \cdot A_c \cdot (f_{ck})_{cy} / \gamma_c + A_s \cdot f_{sk} / \gamma_s$$

$$P_p = A_a \cdot f_y / \gamma_a + \alpha_c \cdot A_c \cdot [0.80 * (f_{ck})_{cu}] / \gamma_c + A_s \cdot f_{sk} / \gamma_s \tag{1}$$

where

A_a , A_c and A_s are the areas of the steel section, the concrete and the reinforcing steel respectively

f_y , $(f_{ck})_{cy}$ and f_{sk} are the yield strength of the steel section, the characteristic compressive strength (cylinder) of the concrete, and the yield strength of the reinforcing steel respectively.

$(f_{ck})_{cu}$ the characteristic compressive strength (cube) of the concrete

α_c strength coefficient for concrete, which is 1.0 for concrete filled tubular sections, and 0.85 for fully or partially concrete encased steel sections.

For ease of expression, $\frac{f_y}{\gamma_a}$, $\frac{\alpha_c(f_{ck})_{cy}}{\gamma_c}$ and $\frac{f_{sk}}{\gamma_s}$ are presented as the design strengths of the respective materials such as p_y , p_{ck} and p_{sk} . Eqn. (1) can therefore be rewritten as follows:

$$P_p = A_a p_y + A_c p_{ck} + A_s p_{sk} \quad (2)$$

At this stage it should be pointed out that the Indian Standards for composite construction (IS:11384-1985) does not make any specific reference to composite columns. The provisions contained in IS: 456 - 2000 are often invoked for design of composite structures. Extension of IS: 456 - 2000 to composite columns will result in the following equation:

$$P_p = A_a p_y + A_c p_{ck} + A_s p_{sk} \quad (2a)$$

where

$$p_y = 0.87f_y ; p_{ck} = 0.4(f_{ck})_{cu} \text{ and } p_{sk} = 0.67f_y \quad (2b)$$

An important design parameter is the steel contribution ratio, β_a which is defined in EC4 as follows:

$$\beta_a = \frac{A_a \times p_y}{P_p} \quad (3)$$

IS: 456 - 2000 is also to be employed for the spacing and design of ties.

4.1.2 Concrete filled circular tubular sections: Special Provisions

The method described above is valid for rectangular and square tubular sections. For composite columns using circular tubular sections, there is an increased resistance of concrete due to the confining effect of the circular tubular section. However, this effect on the resistance enhancement of concrete is significant only in stocky columns. For composite columns with a non-dimensional slenderness of $\bar{\lambda} \leq 0.5$ (where $\bar{\lambda}$ is defined in Eqn.8, in section 4.3), or where the eccentricity, e [defined in Eqn. 4 below], of the applied load does not exceed the value $d/10$, (where d is the outer dimension of the circular tubular section) this effect has to be considered.

The eccentricity, e , is defined as follows:

$$e = \frac{M}{P} \leq \frac{d}{10} \quad (4)$$

where

- e is the eccentricity
- M is the maximum applied design moment (second order effects are ignored)
- P is the applied design load

The plastic compression resistance of concrete filled circular tubular sections is calculated by using two coefficients η_1 and η_2 as given below.

$$P_p = A_a \eta_2 p_y + A_c p_{ck} \left[1 + \eta_1 \frac{t}{d} \frac{f_y}{f_{ck}} \right] + A_s p_{sk} \quad (5)$$

where

- t is the thickness of the circular tubular section.
- η_1 and η_2 two coefficients given by

$$\eta_1 = \eta_{10} \left[1 - \frac{10e}{d} \right] \quad (6)$$

and

$$\eta_2 = \eta_{20} + (1 - \eta_{20}) \frac{10e}{d} \quad (7)$$

In general, the resistance of a concrete filled circular tubular section to compression may increase by 15% under axial load only when the effect of tri-axial confinement is considered. Linear interpolation is permitted for various load eccentricities of $e \leq d/10$. The basic values η_{10} and η_{20} depend on the non-dimensional slenderness $\bar{\lambda}$, which can be read off from Table 5. Non-dimensional slenderness is described in section 4.1.3.

If the eccentricity e exceeds the value $d/10$, or if the non-dimensional slenderness exceeds the value 0.5 then $\eta_1 = 0$ and $\eta_2 = 1.0$.

Table 5: Basic value η_{10} and η_{20} to allow for the effect of tri-axial confinement in concrete filled circular tubular sections, as provided in EC 4 applicable for concrete grades $(f_{ck})_{cy} = 25$ to 55 N/mm^2

	$\bar{\lambda} = 0.0$	$\bar{\lambda} = 0.1$	$\bar{\lambda} = 0.2$	$\bar{\lambda} = 0.3$	$\bar{\lambda} = 0.4$	$\bar{\lambda} \geq 0.5$
η_{10}	4.90	3.22	1.88	0.88	0.22	0.00
η_{20}	0.75	0.80	0.85	0.90	0.95	1.00

4.1.3 Non-dimensional slenderness

The plastic resistance to compression of a composite cross-section P_p , represents the maximum load that can be applied to a short column. For slender columns with low elastic critical load, overall buckling may be critical. In a typical buckling curve for an ideal column as shown in Fig. 4(a), the horizontal line represents P_p , while the curve represents P_{cr} , which is a function of the column slenderness. These two curves limit the compressive resistance of ideal column.

For convenience, column strength curves are plotted in non dimensionalised form as shown in Fig. 4(b) the buckling resistance of a column may be expressed as a proportion χ of the plastic resistance to compression, P_p thereby non-dimensionalising the vertical axis of Fig. 4(a), where χ is called the reduction factor. The horizontal axis may be non-dimensionalised similarly by P_{cr} as shown in Fig. 4(b).

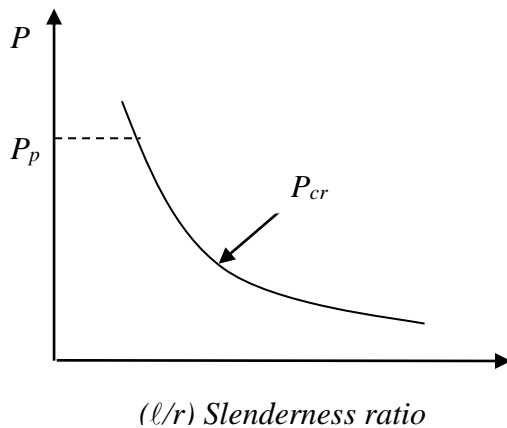

Fig. 4(a): Idealised column buckling curve

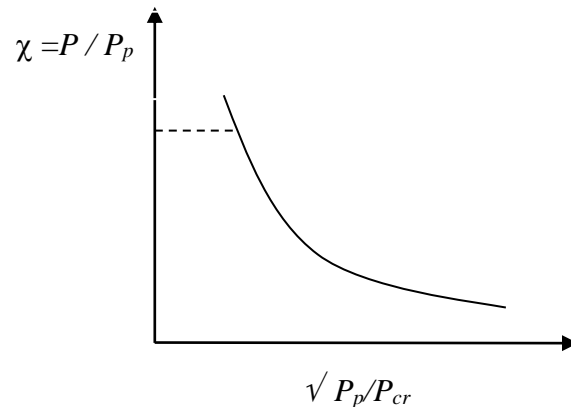

Fig. 4(b) Non-dimensionalised column buckling curve

Practical columns have strength curves different from ideal columns due to residual stresses and geometric imperfections. The European buckling curves have been drawn after incorporating the effects of both residual stresses and geometric imperfections. They form the basis of column buckling design for both steel and composite columns in *EC 3* and *EC4*. For using the European buckling curves, the non-dimensional slenderness of the column should be first evaluated as follows:

$$\bar{\lambda} = \sqrt{\frac{P_{pu}}{P_{cr}}} = \sqrt{\frac{f_y}{\pi^2 E}} \frac{\ell}{r} = f\left(\frac{\ell}{r}\right) \quad (8)$$

where

- P_{pu} plastic resistance of the cross-section to compression, according to Eqn (2) or Eqn. (5) with $\gamma_a = \gamma_c = \gamma_s = 1.0$
 P_{cr} is the elastic buckling load of the column as defined in Eqn. (11).

Once the $\bar{\lambda}$ value of a composite column is established, the buckling resistance to compression of the column may be evaluated as given below.

4.1.4 Local buckling of steel sections

Both Eqns. (2) and (5) are valid provided that local buckling in the steel sections does not occur. To prevent premature local buckling, the width to thickness ratio of the steel sections in compression must satisfy the following limits:

- $\frac{d}{t} \leq 85 \epsilon^2$ for concrete filled circular tubular sections
- $\frac{h}{t} \leq 50 \epsilon$ for concrete filled rectangular tubular sections
- $\frac{b}{t_f} \leq 43 \epsilon$ for partially encased I sections (9)

where

$$\epsilon = \sqrt{\frac{250}{f_y}} \quad (10)$$

f_y is the yield strength of the steel section in $N/mm^2(MPa)$.

For fully encased steel sections, no verification for local buckling is necessary as the concrete surrounding effectively prevents local buckling. However, the concrete cover to the flange of a fully encased steel section should not be less than 40 mm , nor less than one-sixth of the breadth, b , of the flange for it to be effective in preventing local buckling.

Local buckling may be critical in some concrete filled rectangular tubular sections with large h/t ratios. Designs using sections, which exceed the local buckling limits for semi-compact sections, should be verified by tests.

4.2 Effective elastic flexural stiffness

Composite columns may fail in buckling and one important parameter for the buckling design of composite columns is its elastic critical buckling load (Euler Load), P_{cr} , which is defined as follows:

$$P_{cr} = \frac{\pi^2 (EI)_e}{\ell^2} \quad (11)$$

where

$(EI)_e$ is the effective elastic flexural stiffness of the composite column (defined in the next section).

ℓ is the effective length of the column, which may be conservatively taken as system length L for an isolated non-sway composite column.

However, the value of the flexural stiffness may decrease with time due to creep and shrinkage of concrete. Two design rules for the evaluation of the effective elastic flexural stiffness of composite columns are given below.

4.2.1 Short term loading

The effective elastic flexural stiffness, $(EI)_e$, is obtained by adding up the flexural stiffness of the individual components of the cross-section:

$$(EI)_e = E_a I_a + 0.8 E_{cd} I_c + E_s I_s \quad (12)$$

where

I_a , I_c and I_s are the second moments of area of the steel section, the concrete (assumed uncracked) and the reinforcement about the axis of bending considered respectively.

E_a and E_s are the moduli of elasticity of the steel section and the reinforcement

$0.8 E_{cd} I_c$ is the effective stiffness of the concrete; the factor 0.8 is an empirical multiplier (determined by a calibration exercise to give good agreement with test results). Note I_c is the moment of inertia about the centroid of the uncracked column section.

$$E_{cd} = E_{cm} / \gamma_c^* \quad (13)$$

E_{cm} is the secant modulus of the concrete, see Table 2 of the text.

γ_c^* is reduced to 1.35 for the determination of the effective stiffness of concrete according to Eurocode 2.

Note: Dividing the Modulus of Elasticity by γ_m is unusual and is included here to obtain the effective stiffness, which conforms to test data.

4.2.2 Long term loading

For slender columns under long-term loading, the creep and shrinkage of concrete will cause a reduction in the effective elastic flexural stiffness of the composite column, thereby reducing the buckling resistance. However, this effect is significant only for slender columns. As a simple rule, *the effect of long term loading should be considered if the buckling length to depth ratio of a composite column exceeds 15.*

If the eccentricity of loading as defined in Eqn. 4 is more than twice the cross-section dimension, the effect on the bending moment distribution caused by increased deflections due to creep and shrinkage of concrete will be very small. Consequently, it may be neglected and no provision for long-term loading is necessary. Moreover, no provision is also necessary if the non-dimensional slenderness, $\bar{\lambda}$ of the composite column is less than the limiting values given in Table 6

Table 6: Limiting values of $\bar{\lambda}$ for long term loading

	Braced Non-sway systems	Unbraced and/or sway systems
Concrete encased cross-sections	0.8	0.5
Concrete filled cross sections	$\frac{0.8}{1 - \delta}$	$\frac{0.5}{1 - \delta}$

Note: δ is the steel contribution ratio as defined in Eqn. 3.

However, when $\bar{\lambda}$ exceeds the limits given by Table-6 and e/d is less than 2, the effect of creep and shrinkage of concrete should be allowed for by employing the modulus of elasticity of the concrete $E_{c\infty}$ instead of E_{cd} in Eqn. 13, which is defined as follows:

$$E_{c\infty} = E_{cd} \left[1 - \frac{0.5 P_d}{P} \right] \tag{14}$$

where

P is the applied design load.

P_d is the part of the applied design load permanently acting on the column.

The effect of long-term loading may be ignored for concrete filled tubular sections with $\bar{\lambda} \leq 2.0$ provided that δ is greater than 0.6 for braced (or non-sway) columns, and 0.75 for unbraced (and/or sway) columns.

4.3 Resistance of members to axial compression

For each of the principal axes of the column, the designer should check that

$$P \leq \chi P_p \tag{15}$$

where

P_p is the plastic resistance to compression of the cross-section, from Eqn. (2) or Eqn. (5)

χ is the reduction factor due to column buckling and is a function of the non-dimensional slenderness of the composite column.

The European buckling curves illustrated in Fig. 4 (c) are proposed to be used for composite columns. They are selected according to the types of the steel sections and the axis of bending:

- curve *a* for concrete filled tubular sections
- curve *b* for fully or partially concrete encased I-sections buckling about the strong axis of the steel sections (*x-x* axis).
- curve *c* for fully and partially concrete encased I-sections buckling about the weak axis of the steel sections (*y-y* axis).

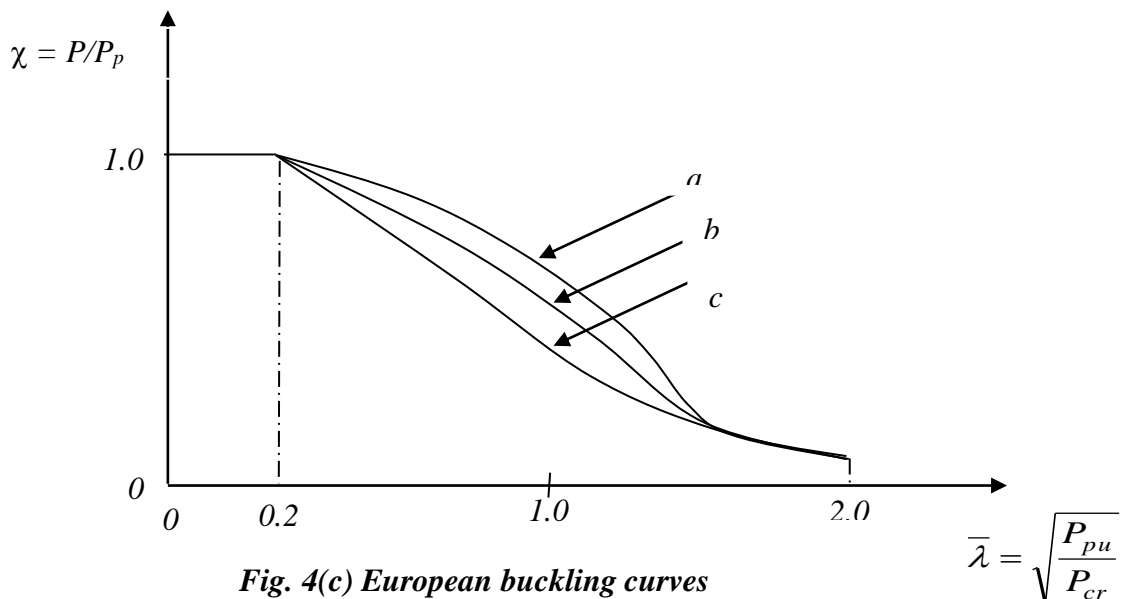

These curves can also be described mathematically as follows:

$$\chi = \frac{I}{\phi + \sqrt{\phi^2 - \bar{\lambda}^2}} \quad \text{but } \chi \leq 1.0 \quad (16)$$

$$\phi = 0.5 \left[1 + \alpha(\bar{\lambda} - 0.2) + \bar{\lambda}^2 \right] \quad (17)$$

where

The factor α allows for different levels of imperfections and residual stresses in the columns corresponding to curves *a*, *b*, and *c*. Table 7 gives the value of α for each buckling curve. Note that the second order moment due to imperfection, has been incorporated in the method by using multiple buckling curves; no additional considerations are necessary.

(It should be noted by way of contrast that *IS: 456-2000* for reinforced concrete columns specifies a 2 cm eccentricity irrespective of column geometry. The method suggested here allows for an eccentricity of load application by the term α . No further provision is necessary for steel and composite columns)

Using the values of $\bar{\lambda}$ determined from Eqn. (8) and the reduction factor χ calculated from Eqn. (16), the design buckling resistance of the composite column to compression, P_b or χP_p may thus be evaluated.

Table 7: Imperfection factor α for the buckling curves

European buckling curve	<i>a</i>	<i>b</i>	<i>c</i>
Imperfection factor α	0.21	0.34	0.49

The isolated non-sway composite columns need not be checked for buckling, if any one of the following conditions is satisfied:

(a) The axial force in the column is less than $0.1 P_{cr}$ where P_{cr} is the elastic buckling load of the column given by Eqn (11)

(b) The non-dimensional slenderness, $\bar{\lambda}$ given by Eqn. (8) is less than 0.2.

5.0 STEPS IN DESIGN

5.1 Design Steps for columns with axial load

5.1.1 List the composite column specifications and the design value of forces and moments.

5.1.2 List material properties such as f_y , f_{sk} , $(f_{ck})_{cy}$, E_a , E_s , E_c

5.1.3 List sectional properties A_a , A_s , A_c , I_a , I_s , I_c of the selected section.

5.1.4 Design checks

(1) Evaluate plastic resistance, P_p of the cross-section from equation,

$$P_p = A_a f_y / \gamma_a + \alpha_c A_c (f_{ck})_{cy} / \gamma_c + A_s f_{sk} / \gamma_s$$

(2) Evaluate effective flexural stiffness, $(EI)_{ex}$ and $(EI)_{ey}$, of the cross-section for short term loading from equations,

$$(EI)_{ex} = E_a I_{ax} + 0.8 E_{cd} I_{cx} + E_s I_{sx}$$

$$(EI)_{ey} = E_a I_{ay} + 0.8 E_{cd} I_{cy} + E_s I_{sy}$$

(3) Evaluate non-dimensional slenderness, $\bar{\lambda}_x$ and $\bar{\lambda}_y$ from equation,

$$\bar{\lambda}_x = \left(\frac{P_{pu}}{(P_{cr})_x} \right)^{\frac{1}{2}}$$

$$\bar{\lambda}_y = \left(\frac{P_{pu}}{(P_{cr})_y} \right)^{\frac{1}{2}}$$

where

$$P_{pu} = A_a f_y + \alpha_c A_c (f_{ck})_{cu} + A_s f_{sk} \quad (\gamma_a = \gamma_c = \gamma_s = 1.0 ; \text{Refer Eqn (8)})$$

$$P_{crx} = \frac{\pi^2 (EI)_{ex}}{\ell^2}$$

$$\text{and } P_{cry} = \frac{\pi^2 (EI)_{ey}}{\ell^2}$$

(4) Check the resistance of the section under axial compression about both the axes.

Design against axial compression is satisfied if following conditions are satisfied:

$$P < \chi_x P_p$$

$$P < \chi_y P_p$$

where

$$\chi_x = \frac{1}{\left(\phi_x + \left\{ \phi_x^2 - \bar{\lambda}_x^2 \right\}^{\frac{1}{2}} \right)}$$

$$\text{and } \phi_x = 0.5 \left[1 + \alpha_x (\bar{\lambda}_x - 0.2) + \bar{\lambda}_x^2 \right]$$

$$\chi_y = \frac{1}{\left(\phi_y + \left\{ \phi_y^2 - \bar{\lambda}_y^2 \right\}^{\frac{1}{2}} \right)}$$

$$\text{and } \phi_y = 0.5 \left[1 + \alpha_y (\bar{\lambda}_y - 0.2) + \bar{\lambda}_y^2 \right]$$

6.0 CONCLUSION

In this chapter the design of steel-concrete composite column subjected to axial load using simplified design method suggested in EC 4 is discussed. The use of European buckling curve in the design of steel-concrete composite column is described. The advantages of steel-concrete composite column and the properties of materials used are also discussed.

A worked example illustrating the use of the above design procedure is appended to this chapter.

NOTATION

A	cross-sectional area
b	breadth of element
d	diameter, depth of element.
e	eccentricity of loading
e_o	initial imperfections
E	modulus of elasticity
$(EI)_e$	effective elastic flexural stiffness of a composite cross-section.
$(f_{ck})_{cu}$	characteristic compressive (cube) strength of concrete
f_{sk}	characteristic strength of reinforcement
f_y	yield strength of steel
$(f_{ck})_{cy}$	characteristic compressive (cylinder) strength of concrete, given by 0.80 times 28 days cube strength of concrete.
f_{ctm}	mean tensile strength of concrete
p_{ck}, p_y, p_{sk}	design strength of concrete, steel section and reinforcement respectively
I	second moment of area (with subscripts)
ℓ	effective length
L	length or span
P	axial force

P_p	plastic resistance to compression of the cross section.
P_{pu}	plastic resistance to compression of the cross section with $\gamma_a = \gamma_c = \gamma_s = 1.0$
P_{cr}	elastic critical load of a column
P_c	axial resistance of concrete, $A_c p_{ck}$
t	thickness of element
Z_e	elastic section modulus
Z_p	plastic section modulus

Greek letters

γ_f	partial safety factor for loads
γ_m	partial safety factor for materials (with subscripts)
γ_c^*	reduction factor(1.35) used for reducing E_{cm} value
$\bar{\lambda}$	slenderness ($\bar{\lambda}$ = non-dimensional slenderness)
ε	coefficient = $\sqrt{250 / f_y}$
α	imperfection factor
α_c	strength coefficient for concrete
χ	reduction factor buckling
η_c	reduction factor on axial buckling resistance P_b for long term loading
β_a	steel contribution ratio, $A_a p_y / P_p$
s	reinforcement
w	web of steel section
d	dead load
l	live load

Note-The subscript x , y denote the x - x and y - y axes of the section respectively. x - x denotes the major axes whilst y - y denotes the minor principal axes.

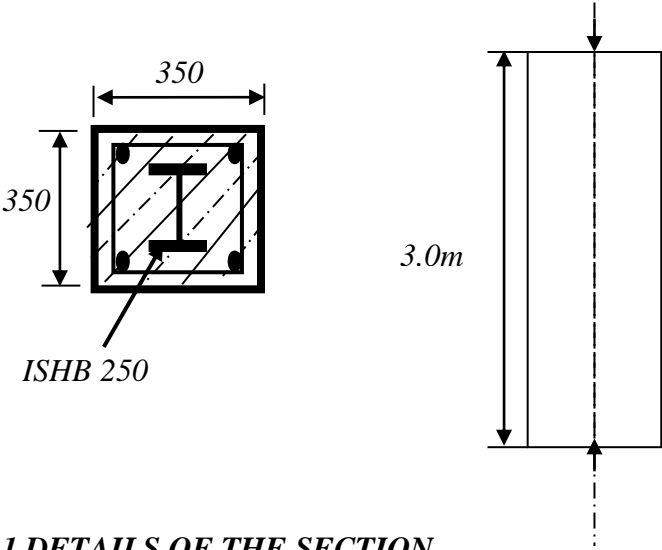
<h1>Structural Steel Design Project</h1>	Job No:	Sheet <i>1 of 6</i>	Rev
	Job Title: <i>Composite Column Design</i>		
	Worked Example: <i>I</i>		
		Made By <i>PU</i>	Date
<h2>Calculation Sheet</h2>		Checked By <i>RN</i>	Date
<p><u>PROBLEM I</u></p> <p><i>Obtain plastic resistance of a steel section made of ISHB 250 encased in concrete. The height of the column is 3.0m and is pin ended.</i></p>			
			
<p><u>5.1.1 DETAILS OF THE SECTION</u></p>			
<i>Column dimension</i>	<i>350 X 350 X 3000</i>		
<i>Concrete Grade</i>	<i>M30</i>		
<i>Steel Section</i>	<i>ISHB 250</i>		
<i>Reinforcement steel area</i>	<i>Fe 415</i> <i>0.5% of gross concrete area.</i>		
<i>Cover from the flanges</i>	<i>50 mm</i>		
<i>Height of the column</i>	<i>3000 mm</i>		

<h1>Structural Steel Design Project</h1> <h2>Calculation Sheet</h2>	Job No:	Sheet <i>2 of 6</i>	Rev
	Job Title: <i>Composite Column Design</i>		
	Worked Example: <i>1</i>		
		Made By <i>PU</i>	Date
	Checked By <i>RN</i>	Date	
<p>5.1.2 LIST MATERIAL PROPERTIES</p> <p>(1) Structural steel</p> <p><i>Steel section ISHB 250</i> <i>Nominal yield strength $f_y = 250 \text{ N/mm}^2$</i> <i>Modulus of elasticity $E_a = 200 \text{ kN/mm}^2$</i></p> <p>(2) Concrete</p> <p><i>Concrete grade M30</i> <i>Characteristic strength (cube), $(f_{ck})_{cu} = 30 \text{ N/mm}^2$</i> <i>Characteristic strength (cylinder), $(f_{ck})_{cy} = 25 \text{ N/mm}^2$</i> <i>Secant modulus of elasticity for short term loading, $E_{cm} = 31220 \text{ N/mm}^2$</i></p> <p>(3) Reinforcing steel</p> <p><i>Steel grade Fe 415</i> <i>Characteristic strength $f_{sk} = 415 \text{ N/mm}^2$</i> <i>Modulus of elasticity $E_s = 200 \text{ kN/mm}^2$</i></p> <p>(4) Partial safety factors</p> <p>$\gamma_a = 1.15$</p> <p>$\gamma_c = 1.5$</p> <p>$\gamma_s = 1.15$</p> <p>5.1.3 LIST SECTION PROPERTIES OF THE GIVEN SECTION</p> <p>(1) Steel section</p> <p>$A_a = 6971 \text{ mm}^2$</p>			

<h1>Structural Steel Design Project</h1> <h2>Calculation Sheet</h2>	Job No:	Sheet 3 of 6	Rev
	Job Title: Composite Column Design		
	Worked Example: 1		
		Made By PU	Date
	Checked By RN	Date	
<p> $h = 250 \text{ mm}$ $t_w = 8.8 \text{ mm}$ $I_{ax} = 79.8 * 10^6 \text{ mm}^4$ $I_{ay} = 20.1 * 10^6 \text{ mm}^4$ </p> <p>(2) Reinforcing steel</p> <p>Area reinforcement = 0.5% of gross concrete area = $0.5/100 * (115529)$ $= 578 \text{ mm}^2$</p> <p>Provide 4 bars of 14 mm dia., $A_s = 616 \text{ mm}^2$</p> <p>(3) Concrete</p> $A_c = A_{gross} - A_a - A_s$ $= 350 * 350 - 6971 - 616$ $= 114913 \text{ mm}^2$ <p>5.1.4 DESIGN CHECKS</p> <p>(1) Plastic resistance of the section</p> $P_p = A_a f_y / \gamma_a + \alpha_c A_c (f_{ck})_{cy} / \gamma_c + A_s f_{sk} / \gamma_s$ $P_p = A_a f_y / \gamma_a + \alpha_c A_c (0.80 * (f_{ck})_{cu}) / \gamma_c + A_s f_{sk} / \gamma_s$ $= [6971 * 250 / 1.15 + 0.85 * 114913 * 25 / 1.5 + 616 * 415 / 1.15] / 1000$ $= 3366 \text{ kN}$ <p style="text-align: right;">$P_p = 3366 \text{ kN}$</p> <p>(2) Calculation of Effective elastic flexural stiffness of the section</p> <p><u>About the major axis</u></p> $(EI)_{ex} = E_a I_{ax} + 0.8 E_{cd} I_{cx} + E_s I_{sx}$ $I_{ax} = 79.8 * 10^6 \text{ mm}^4$			

<h1>Structural Steel Design Project</h1>	Job No:	Sheet 4 of 6	Rev
	Job Title: Composite Column Design		
	Worked Example: I		
		Made By PU	Date
<h2>Calculation Sheet</h2>		Checked By RN	Date
$I_{sx} = Ah^2$ $= 616 * [350/2-25-7]^2$ $= 12.6 * 10^6 \text{ mm}^4$			E_{cd} $= E_{cm} / \gamma_c^*$ $= 31220 / 1.35$ $= 23125 \text{ N/mm}^2$
$I_{cx} = (350)^4/12 - [79.8 + 12.6] * 10^6$ $= 1158 * 10^6 \text{ mm}^4$			
$(EI)_{ex} = 2.0 * 10^5 * 79.8 * 10^6 + 0.8 * 23125 * 1158.09 * 10^6 + 2.0 * 10^5 * 12.6 * 10^6$ $= 39.4 * 10^{12} \text{ N mm}^2$			
<p><u>About minor axis</u></p> $(EI)_{ey} = 28.5 * 10^{12} \text{ N mm}^2$			
<p>(3) Non dimensional slenderness</p>			
$\bar{\lambda} = (P_{pu}/P_{cr})^{1/2}$			
<p>Value of P_{pu} ($\gamma_a = \gamma_c = \gamma_s = 1.0$)</p>			
$P_{pu} = A_a f_y + \alpha_c A_c (f_{ck})_{cy} + A_s f_{sk}$			
$P_{pu} = A_a f_y + \alpha_c A_c * 0.80 * (f_{ck})_{cu} + A_s f_{sk}$			
$= 6971 * 250 + 0.85 * 114913 * 25 + 415 * 616$			
$= 44.40 * 10^5 \text{ N}$			
$= 4440 \text{ kN}$			
$(P_{cr})_x = \frac{\pi^2 (EI)_{ex}}{\ell^2}$			
$= \frac{\pi^2 * 39.4 * 10^{12}}{(3000)^2}$			
$= 43207 \text{ kN}$			
			$P_{pu} = 4440 \text{ kN}$
			$(P_{cr})_x$ $=$ 43207 kN

<h1>Structural Steel Design Project</h1> <h2>Calculation Sheet</h2>	Job No:	Sheet 5 of 6	Rev
	Job Title: Composite Column Design		
	Worked Example: I		
		Made By PU	Date
	Checked By RN	Date	
$(P_{cr})_y = \frac{\pi^2 * 28.5 * 10^{12}}{(3000)^2} = 31254 \text{ kN}$ $\bar{\lambda}_x = (44.40 / 432.07)^{\frac{1}{2}} = 0.320$ $\bar{\lambda}_y = (44.40 / 312.54)^{\frac{1}{2}} = 0.377$		$(P_{cr})_y = 31254 \text{ kN}$	
<p>(4) Resistance of the composite column under axial compression</p> <p><i>Buckling resistance of the section should satisfy the following condition</i></p> $P_b < \chi P_p$ <p>where</p> <p>P_b = buckling load</p> <p>χ = reduction factor for column buckling</p> <p>P_p = plastic resistance of the section</p> $= 3366 \text{ kN}$ <p>χ values :</p> <p><u>About major axis</u></p> $\alpha_x = 0.34$			

<h1>Structural Steel Design Project</h1>	Job No:	Sheet 6 of 6	Rev
	Job Title: Composite Column Design		
	Worked Example: 1		
		Made By PU	Date
<h2>Calculation Sheet</h2>		Checked By RN	Date
$\chi_x = 1 / \{ \phi_x + (\phi_x^2 - \bar{\lambda}_x^2)^{1/2} \}$ $\phi_x = 0.5 [1 + \alpha_x (\bar{\lambda}_x - 0.2) + \bar{\lambda}_x^2]$ $= 0.5 [1 + 0.34(0.320 - 0.2) + (0.320)^2] = 0.572$ $\chi_x = 1 / \{ 0.572 + [(0.572)^2 - (0.320)^2]^{1/2} \}$ $= 0.956$ <p><u>About minor axis</u></p> $\alpha_y = 0.49$ $\phi_y = 0.61$ $\chi_y = 0.918$ $(P_b)_x = \chi_x P_P$ $= 0.956 * 3366 = 3218 \text{ kN}$ $(P_b)_y = \chi_y P_P$ $= 0.918 * 3366 = 3090 \text{ kN}$ <p>Hence, the lower value of plastic resistance against buckling, $P_b = 3090 \text{ kN}$</p>			<p>Lower value of plastic resistance = 3090 kN</p>