

2**CORROSION, FIRE PROTECTION AND FATIGUE
CONSIDERATIONS OF STEEL STRUCTURES****1.0 INTRODUCTION**

Corrosion, fire protection and fatigue failure of steel structures are some of the main concerns of an engineer involved in the design and construction of structural steel work and these aspects do warrant extra attention. A review of international literature and the state of the art in constructional steelwork would reassure the designer that many aspects of corrosion, fire and fatigue behaviour of structural steel work, are no longer the major issues. For example, the steel construction industry has developed excellent protective coatings that would retain service life even after 20 years without any serious attention! Similarly the emergence of ‘fire engineering of steel structures’ as a specialised discipline has addressed many of the concerns regarding the structural steel work under fire. In India ‘Fire Resistant Steels (FRS)’ are available which are quite effective in steelwork subjected to elevated temperatures. They are also cost effective compared to mild steel! Similarly, fatigue behaviour of steel structural systems has been researched extensively in the past few decades and has been covered excellently in the published literature. Many countries have a separate code of practice, which deals exclusively with the fatigue resistance design of steel structural systems. Today, substantial information and guidelines are available to the designers so that these three aspects could be handled in a routine manner. In this chapter we will review aspects of corrosion, fire protection and fatigue behaviour of structural steelwork briefly and outline suitable prevention methods.

2.0 CORROSION OF STEEL

There is a mindset among many Indian designers, that steel corrodes the most in India compared to other countries. This conception is very much untrue! No doubt, steel corrodes all over the world but the difference is, the problem is better tackled in the advanced countries. With the advent of new technologies of corrosion protection and better understanding of the material behaviour of steel, corrosion of steel no longer causes any undue worry for structural designers involved in structural steelwork. Nevertheless, a designer involved in structural steel work must be aware of the phenomena of corrosion and its prevention methods, both simple and detailed.

2.1 Corrosion mechanism as a miniature battery

Every metal found in nature has a characteristic electric potential, based on its atomic structure and also the ease with which the metal can produce or absorb electrons. Those metals, which provide electrons more readily, are called anodes and those that absorb electrons are called cathodes. Anodes and cathodes are called electrodes and if they get connected in the presence of an electrolyte (a conducting medium), they form a battery as shown in Fig.1.

© Copyright reserved

No material individually can be called as cathode or anode, as they can serve both the functions depending on the relative potential of the material to which they are connected. For example, steel is anodic in the presence of stainless steel or brass and cathodic in the presence of zinc or aluminium. From the mechanism shown in Fig. 1, we see that two bodies of different electric potential electrically connected together in the presence of an electrolyte, the anodic body provide electrons to the cathode (To remember easily: Anodes–Away; Cathodes–Collect). In this process the anode is gradually destroyed, in other words it corrodes. On the other hand, a body will not corrode until it is immersed in or wetted by an electrolytic solution and gets electrically connected to another body having a more positive electric potential. This is the main principle called “*eliminate the electrolyte*”, using which we devise many of the corrosion prevention methods, in structural steel work.

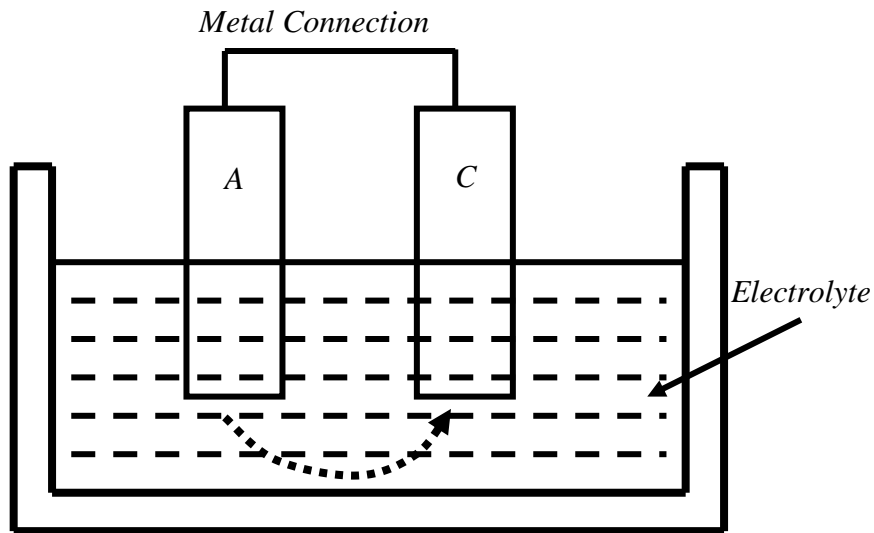

Fig.1 Mechanism of corrosion as a miniature battery

2.2 Corrosion of steel

In the case of steel, when favourable condition for corrosion occurs, the ferrous ions go into solution from anodic areas. Electrons are then released from the anode and move through the cathode where they combine with water and oxygen to form hydroxyl ions. These react with the ferrous ions from anode to produce hydrated ferrous oxide, which further gets oxidised into ferric oxide, which is known as the ‘*red rust*’. Let us consider a portion of steel member, which is slightly rusted as shown in Fig. 2.

The portion of the surface protected by the oxide film (rust) would be cathodic with respect to a portion, which is not so protected. Therefore, there will be a difference in electrical potential and hence the anode will corrode, forming rust on its surface. As rust builds up on one portion of the body, it becomes less anodic with respect to a previously rusted area. In this way they form and reform batteries and corrode the entire surface.

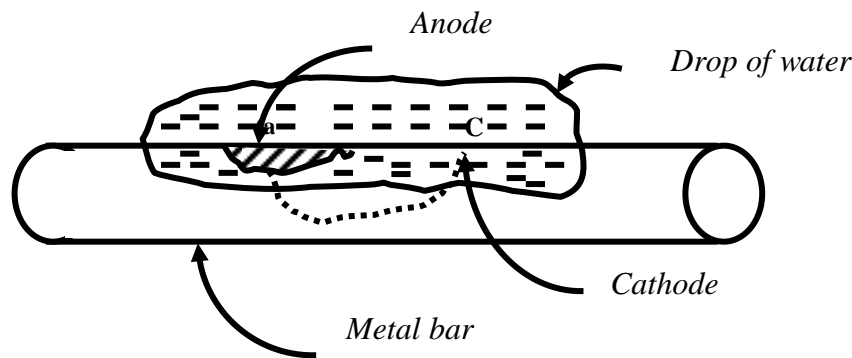

Fig. 2 Mechanism of Corrosion in steel

From the above discussion, it is clear, that the main interest of the structural designers is to prevent the formation of these “corrosion batteries”. For example, if we can wipe out the ‘drop of water’ shown in Fig. 2, the corrosion will not take place! Hence using the “*eliminate the electrolyte*” principle, wherever possible we need to devise detailing and protection to surfaces of structural steel work to ensure that the combination of oxygen and water are avoided and hence the corrosion batteries are avoided.

2.3 Types of corrosion encountered in practice

Let us briefly review the types of corrosion encountered in structural steel elements:

Pitting corrosion: As shown in Fig. 2, The anodic areas form a corrosion pit. This can occur with mild steel immersed in water or soil. This common type of corrosion is essentially due to the presence of moisture aided by improper detailing or constant exposure to alternate wetting and drying. This form of corrosion could easily be tackled by encouraging rapid drainage by proper detailing and allowing free flow of air, which would dry out the surface.

Crevice corrosion: This again is due to improper detailing where the tops of the crevices become localised anodes and corrosion occurs at this point. The principle of crevice corrosion is exemplified in Fig. 3. The oxygen content of water trapped in a crevice is less than that of water, which is exposed to air. Because of this the crevice becomes anodic with respect to surrounding metal and hence the corrosion starts inside the crevice.

Bimetallic corrosion: When two dissimilar metals (for e.g. Iron and Aluminium) are joined together in an electrolyte, an electrical current passes between them and the corrosion occurs. This is because, metals in general could be arranged, depending on their electric potential, into a table called the ‘galvanic series’. The farther the metals in the galvanic series, the greater the potential differences between them causing the anodic metal to corrode. A common example is the use of steel screws in stainless steel members and also using steel bolts in aluminium members. This type of bi-metallic corrosion is easy to spot and understand. Obviously such a contact between dissimilar metals should be avoided in detailing.

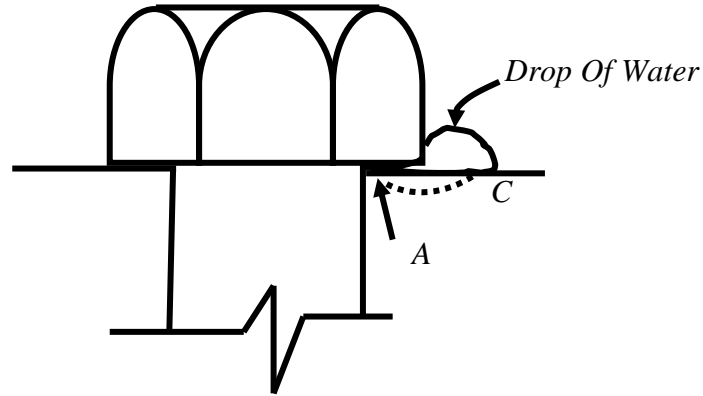

Fig.3 Mechanism of crevice corrosion

Stress corrosion: This occurs under the simultaneous influence of a static tensile stress and a specific corrosive environment. Stress makes some spots in a body more anodic (especially the stress concentrated zones) compared with the rest as shown in Fig. 4. The crack tip in Fig. 4 is the anodic part and it corrodes to make the crack wider. This corrosion is not common with ferrous metals though some stainless steels are susceptible to this.

Fretting corrosion: If two oxide coated films or rusted surfaces are rubbed together, the oxide film can be mechanically removed from high spots between the contacting surfaces as shown in Fig. 5.

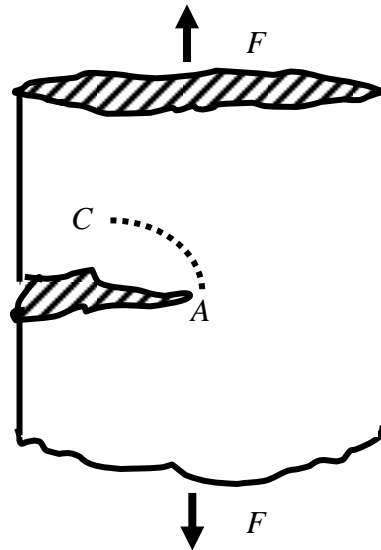

Fig. 4 Mechanism of stress corrosion

These exposed points become active anodes compared with the rest of the surfaces and initiate corrosion. This type corrosion is common in mechanical components.

Bacterial corrosion: This can occur in soils and water as a result of microbiological activity. Bacterial corrosion is most common in pipelines, buried structures and offshore structures.

Hydrogen embrittlement: This occurs mostly in fasteners and bolts. The atomic hydrogen may get absorbed into the surface of the fasteners. When tension is applied to these fasteners, hydrogen will tend to migrate to points of stress concentration. The pressure created by the hydrogen creates and/or extends a crack. The crack grows in subsequent stress cycles. Although hydrogen embrittlement is usually included in the discussion about corrosion, actually it is not really a corrosion phenomenon.

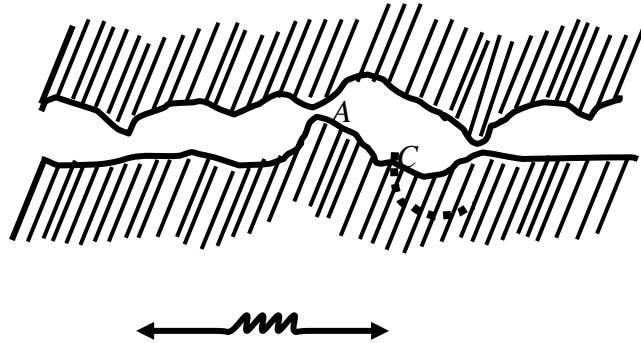

Fig. 5 The mechanism of fretting corrosion

3.0 CORROSION PROTECTION TO STRUCTURAL STEEL ELEMENTS

Taking care of the following points can provide satisfactory corrosion protection to most structural steel elements:

- Avoiding of entrapment and accumulation of moisture and dirt in components and connections by suitable detailing as shown in Fig. 6

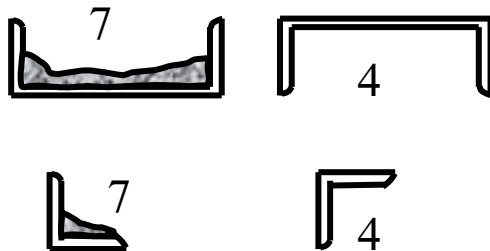

Fig.6 Simple orientation of members to avoid dirt and water entrapment

- Avoiding contact with other materials such as bimetallic connections, as explained in the earlier section.
- Detailing the structural steel work to enhance air movement and thereby keeping the surfaces dry as shown in Fig.7
- Providing suitable drain holes wherever possible to initiate easy draining of the entrapped water as shown in Fig. 8

- Providing suitable access to all the components of steel structures for periodic maintenance, cleaning and carrying out inspection and maintenance at regular intervals.
- Providing coating applications to structural steel elements. Metallic coatings such as hot-dip galvanising, metal spray coatings, etc. are very effective forms of corrosion protection. Cleaning of the surfaces and applying suitable paints is the most commonly used and reliable method of corrosion protection. This is discussed in detail in the next section.

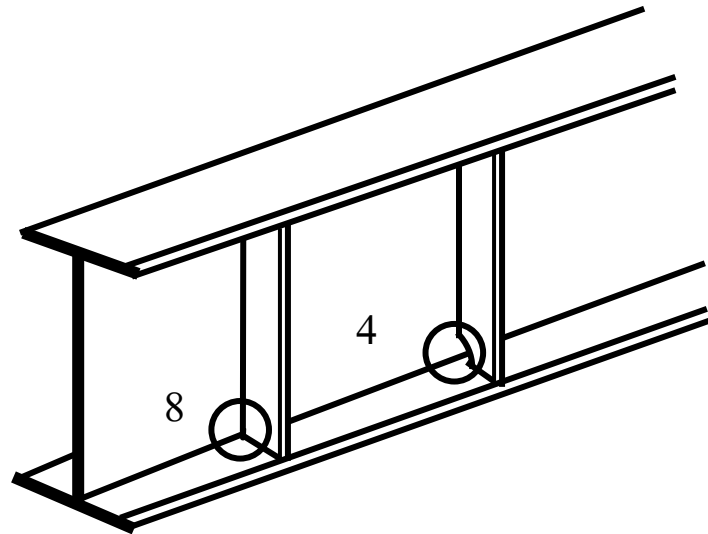

Fig.7 Detailing to enhance air movement between joints

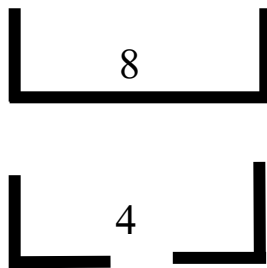

Fig.8 Provision of drain holes wherever possible.

3.1 Surface preparation

Before applying any protective coating to structural steel work, it is very essential that the surface must be free of dirt and other materials that would affect its adhesion. In this section we review the surface preparation methods which are commonly employed in structural steel work.

Structural steel comes out of the mill with a mill scale on its surface. On weathering, water penetrates into the fissures of the mill scale and rusting of the steel surface occurs. The mill scale loses its adhesion and begins to shed. Mill scale therefore needs to be removed before any protection coatings are applied. The surface of steel may also contain dirt or other impurities during storage, transportation and handling. The various surface preparation methods are briefly explained below.

Manual preparation: This is a very economical surface cleaning method but only 30% of the rust and scale may be removed. This is usually carried out with a wire brush.

Mechanical preparation: This is carried out with power driven tools and up to 35% cleaning can be achieved. This method is quite fast and effective.

Flame cleaning: In this process an Oxy-gas flame causes differential thermal expansion and removes mill scale more effectively.

Acid pickling: This involves the immersion of steel in a bath of suitable acids to remove rust. Usually this is done before hot dip galvanising (explained in the next section).

Blast cleaning: In this process, abrasive particles are projected at high speed on to the steel surface and cleaning is effected by abrasive action. The common blast cleaning method is the ‘sand blasting’. However in some states of India, sand blasting is not allowed due to some environmental reasons.

3.2 Preventive coatings

The principal protective coatings applied to structural steel work are paints, metal coatings or combination of these two. Paints basically consist of a pigment, a binder and solvent. After the paint has been applied as a wet film, the solvent evaporates leaving the binder and the pigment on the surface. In codes of practices relating to corrosion protection, the thickness of the primer, the type of paints and the thickness of the paint in term of microns are specified depending upon the corrosive environment. The codes of practice also specify the frequency with which the change of paint is required. Metal coatings on structural steel work are almost either zinc or aluminium. Hot dip Zinc coatings known as “galvanising”, involves dipping of the steelwork into a bath of molten Zinc at a temperature of about 450⁰C. The work piece is first degreased and cleaned by pickling to enhance the wetting properties. Sometimes hot dip aluminising is also done. Alternatively, metal coating could also be applied using metal spraying.

3.3 Weathering steels

To protect steel from corrosion, some countries produce steels which by themselves can resist corrosion. These steels are called as “*weathering steels or Corten steels*”. Weathering steels are high strength alloy weldable structural steels, which possess excellent weathering resistance in many non-polluted atmospheric conditions. They contain up to 3% of alloying elements such as chromium, copper, nickel, phosphorous, etc. On exposure to air, under suitable conditions, they form adherent protective oxide coatings. This acts as a protective film, which with time and appropriate conditions causes the corrosion rate to reduce until it is a low terminal level. Conventional coatings are, therefore, not usually necessary since the steel provides its own protection.

Weathering steels are 25% costlier than the mild steel, but in many cases the total cost of the structure can be reduced if advantage is taken of the 30% higher yield strength compared to mild steel.

3.4 Where does corrosion matter in structural steel work?

The corrosion of steel in a dry interior environment is virtually insignificant. For example, structural steel work in the interiors of offices, shops, schools, hostels, residences, airport terminals, hospitals etc. will not corrode noticeably during the expected 50-year life of the structure. Hence *in these situations no protective coating is required and the structural steel work may be left exposed*. Only when the structural steel work is exposed to moisture in an interior environment such as kitchens, sports halls etc. a little attention is needed in the detailing of the steel work and also thin protective coatings. Structural steel work will need protective coatings in slightly intensive corrosive environment such as some industrial buildings, dairies, laundries, breweries etc. The above mentioned situations can be termed as ‘low to medium’ risk categories. Structural steel work exposed to high humidity and atmosphere, chemical plants, foundries, steel bridges, offshore structures would fall into the “high risk” category. Structural steel work that is categorised into high-risk group requires better surface preparation and sufficient thickness of the anti-corrosive paints. As we review the protective coatings such as the paints available in the market to-day many of the paints can perform very satisfactorily for 5-7 years. Specially prepared epoxy paints when applied in sufficient thickness after a good surface preparation, can last as high as 20 years!! Corrosion of steel is no longer the major problem that it once was and the protective methods no longer pose any major disincentive for using steel in the building industry. For the purpose of selecting a suitable paint system, if appropriate, the risk groups of structural steel work are classified according to their location and their intended service; however the same classification can also be done depending on the exterior environment of the structural steel work as in Table.1

Table 1 Exterior environment and corrosion risk (Source: British Steel)

| No. | Exterior Environment | Areas appropriate | Corrosion risk |
|-----|----------------------|---|----------------|
| 1. | Normal Inland | Most rural and urban areas | Low |
| 2. | Polluted Inland | High airborne sulphur dioxide | Significant |
| 3. | Normal Coastal | As normal inland plus high airborne salt levels | High |
| 4 | Polluted Coastal | As polluted inland plus high airborne salt levels | Very high |

In the aggressive environment such as the cases 2,3 and 4 in Table 1, appropriate technologies are available to counter corrosion. There is a range of corrosion protection methods, depending upon the environment and desired life of the protection method, the details of which are presented briefly in Table 2. Expert help should be obtained when the corrosion risk is “high” or “very high”.

3.5 Summary of corrosion prevention methods

The mechanism of corrosion and the possible ways of its prevention has been discussed in the foregoing sections. The following are the three broad categories of corrosion prevention methods.

- I. As mentioned earlier, corrosion does not occur in the absence of water. Corrosion protection can be achieved by a number of methods (e.g.)
 - (a) Application of coatings to separate the metal from its environment.
 - (b) Avoiding exposure to moisture and air.
 - (c) Attention to detailing of the structures to encourage rapid drainage of water.
- II Corrosion does not occur in the absence of Oxygen and water. This can be achieved by
 - (a) Deaeration of water
 - (b) De-humidification of the atmosphere
 - (c) Application of certain surface coatings
- III Corrosion does not occur if the basic electro-chemical reaction is suppressed
 - (a) The use of corrosion inhibitors would suppress either anodic or cathodic reactions and hence the corrosion is prevented.
 - (b) The other method is the application of cathodic protection, which floods the surface with free electrons and prevents formation of anodes.

4.0 STEEL STRUCTURES SUBJECTED TO FIRE

In this section a brief review of aspects of structural steel work subjected to fire is given. The strength of all engineering materials reduces as their temperature increases.

Steel is no exception. However, a major advantage of steel is that it is incombustible and it can fully recover its strength following a fire, most of the times. Fire represents a transfer of energy from a stable condition to a transient condition as combustion occurs. The common examples of fire that affects structural systems are burning of office furniture, books, and contents of filing cabinet or other materials. During the fire steel absorbs a significant amount of thermal energy. After this exposure to fire, steel returns to a stable condition after cooling to ambient temperature. During this cycle of heating and cooling, individual steel members may become slightly bent or damaged, generally without affecting the stability of the whole structure. From the point of view of economy, a significant number of steel members may be salvaged following a post-fire review of a fire affected steel structure. Using the principle “*If the member is straight after exposure to fire – the steel is O.K*”, many steel members could be left undisturbed for the rest of their service life. Steel members which have slight distortions may be made dimensionally reusable by simple straightening methods and the member may be put to continued use with full expectancy of performance with its specified mechanical properties. The members which have become unusable due to excessive deformation may simply be scrapped. In effect, it is easy to retrofit steel structures after fire.

Table 2 Corrosion protection treatment in External environment

| Shop applied treatments | | | | | | |
|--------------------------------|--|--|-------------------|--------------------------------------|----------------------------------|--|
| | Option 1 | Option 2 | Option 3 | Option 4 | Option 5 | Option 6 |
| Surface preparation | Blast clean | Blast clean | Blast clean | Blast clean | Grit blast | Blast clean |
| Pre fabrication primer | Zinc phosphate epoxy | 2 pack Zinc rich epoxy | ----- | 2 pack Zinc rich epoxy | ---- | Ethyl Zinc Silicate |
| Post fabrication primer | High build Zinc phosphate modified alkyd | 2 pack Zinc rich epoxy | Hot dip galvanise | 2 pack Zinc rich epoxy | Sprayed Zinc or Sprayed Aluminum | Ethyl Zinc Silicate |
| Intermediate coat | ---- | High build Zinc phosphate | | 2 pack epoxy Micaceous iron oxide | Sealer | Chlorinated rubber alkyd |
| Top coat | ---- | ---- | ---- | 2 pack epoxy Micaceous Iron oxide | Sealer | ---- |
| Site applied treatments | | | | | | |
| Surface preparation | As necessary | As necessary | No site treatment | As necessary | No site treatment | As necessary |
| Primer | Touch in | Touch in | ---- | ---- | ---- | Touch in |
| Intermediate coat | ---- | Modified Alkyd Micaceous Iron Oxide | ---- | Touch in | --- | High build Micaceous Iron oxide chlorinated rubber |
| Top coat | High build Alkyd finish | Modified Alkyd Micaceous Iron Oxide | ---- | High build chlorinated rubber | ---- | High build Micaceous Iron oxide chlorinated rubber |
| Expected life in years | | | | | | |
| Normal Inland | 12 | 18 | 20 | (+ -) 20 | (+ -) 20 | 20+ |
| Polluted Inland | 10 | 15 | 12 | (+ -) 18 | (+ -) 15-20 | 20+ |
| Normal coastal | 10 | 12 | 20 | (+ -) 20 | (+ -) 20 | 20+ |
| Polluted coastal | 8 | 10 | 10 | (+ -) 15 | (+ -) 15-20 | 20+ |

In the case of concrete exposed to fire, it will start changing its colour to pink at about 285⁰C and will turn into deep red at about 590⁰C. Soon after that, concrete would turn into quartz aggregate and spalling would start. The degree of spalling is dependent upon the rate of temperature rise, moisture content and maximum temperature for each type of aggregate. Hence it seen that concrete exposed to fire beyond say 600⁰C, may undergo an irreversible degradation in mechanical strength unlike steel where much of its original strength is regained. The above points underline the advantage of steel in terms of economy even in the case of fire.

4.1 Fire loads and fire rating of steel structures

The term ‘fire load’ in a compartment of a structure is the maximum heat that can be theoretically generated by the combustible items and contents of the structure. The fire load could be measured as the weight of the combustible material multiplied by the calorific value per unit weight. Fire load is conveniently expressed in terms of the floor space as MJ/m² or Mcal/m². More often it would be expressed in terms of equivalent quantity of wood and expressed as Kg wood / m² (1 Kg wood = 18MJ). The commonly encountered fire loads are presented in Table 3. The values are just an indication of the amount of fire load and the values may change from one environment to the other and also from country to country.

Table 3 Fire load on steel structures

| Examples of fire load in various structures | |
|--|--------------------------------|
| <i>Type of steel structure</i> | <i>Kg wood / m²</i> |
| School | 15 |
| Hospital | 20 |
| Hotel | 25 |
| Office | 35 |
| Departmental store | 35 |
| Textile mill show room | >200 |

The fire rating of steel structures are expressed in units of time ½, 1, 2, 3 and 4 hours etc. The specified time neither represents the time duration of the real fire nor the time required for the occupants to escape. The time parameters are basically a convenient way of comparative grading of buildings with respect to fire safety.

Basically they represent the endurance of structural steel elements under standard laboratory conditions. Fig. 9 represents the performance of protected and unprotected steel in a laboratory condition of fire. The rate of heating of the unprotected steel is obviously quite high as compared to the fire-protected steel. We shall see in the following sections that these two types of fire behaviour of steel structure give rise to two different philosophies of fire design. The time equivalence of fire resistance for steel structures or the fire rating could be calculated as

$$T_{eq}(\text{Minutes}) = CWQ_f \quad (1)$$

where Q_f is the fire load MJ/m² which is dependent on the amount of combustible material, 'W' is the ventilation factor relating to the area and height and width of doors and windows and 'C' is a coefficient related to the thermal properties of the walls, floors and ceiling. As an illustration, the "W" value for a building with large openings could be chosen as 1.5 and for highly insulating materials "C" value could be chosen as 0.09.

4.2 Mechanical properties of steel at elevated temperatures

We need to know about the mechanical properties of steel at elevated temperatures in the case of fire resistant design of structural steel work. Hence in this section we review the important mechanical aspects of steel at elevated temperatures. The variations of the non-dimensional modulus of elasticity, yield strength and coefficient of thermal expansion with respect to temperature are shown in Fig. 10. The corresponding equations are given below. The variation of modulus of elasticity ratio \bar{E} with respect to the corresponding value at 20°C, with respect to temperature T is given by

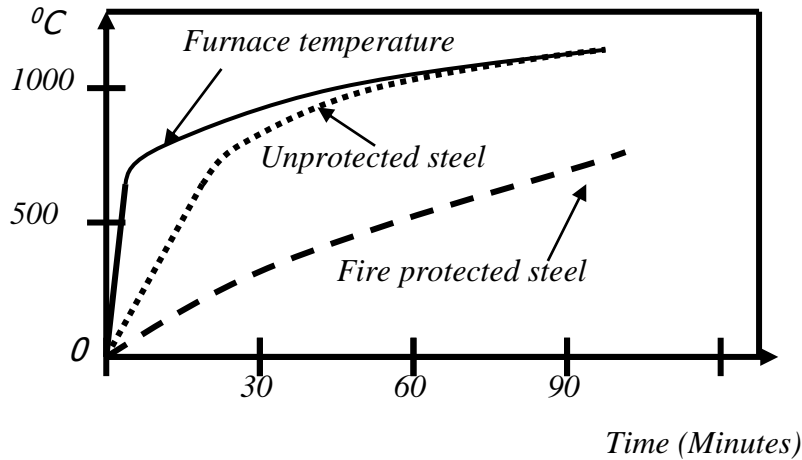

Fig. 9 Rate of heating of structural steel work

$$\bar{E} = \frac{E(T)}{E(20^{\circ}\text{C})} = 1.0 + \frac{T}{2000 \ln \left[\frac{T}{1100} \right]} \quad \text{for } 0^{\circ}\text{C} < T < 600^{\circ}\text{C} \quad (2)$$

$$= \frac{690(1.0 - \frac{T}{1000})}{T - 53.5} \quad \text{for } 600^{\circ}\text{C} < T < 1000^{\circ}\text{C}$$

The yield stress of steel remains unchanged up to a temperature of about 215°C and then

loses its strength gradually. The yield stress ratio \bar{f} (with respect to yield stress at 20°C) vs. temperature T relation is given by

$$\bar{f} = \frac{f_y(T)}{f_y(20)} = 1.0 \quad 0^{\circ}C < T < 215^{\circ}C$$

$$= \frac{905 - T}{690} \quad 215^{\circ}C < T < 905^{\circ}C$$
(3)

Similarly the coefficient of thermal expansion α also varies with temperature by a simple relation

$$\alpha(T) = (12.0 + \frac{T}{100}) \times 10^{-6} \quad (^{\circ}C)^{-1}$$
(4)

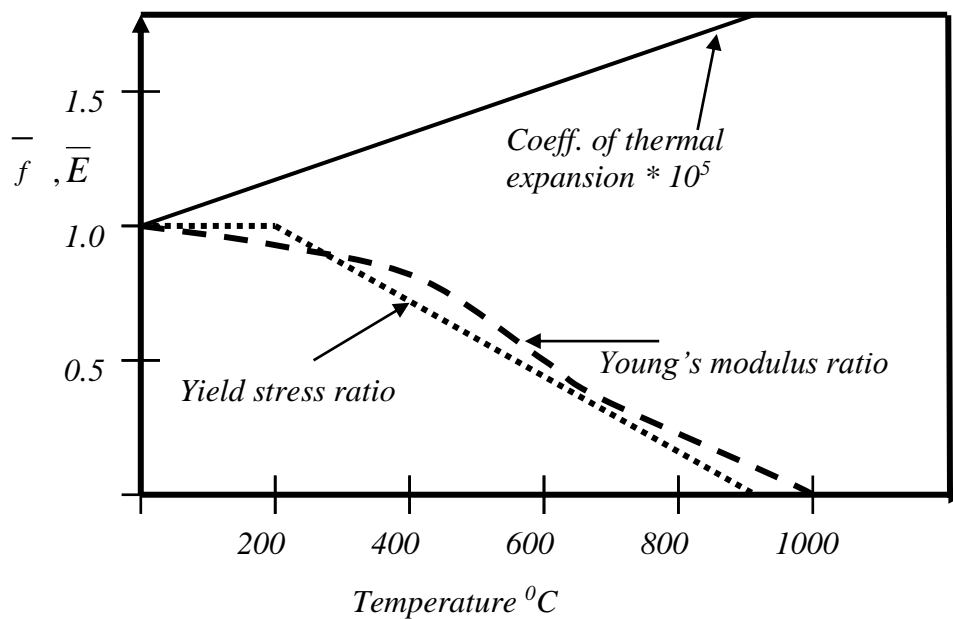

Fig.10 Mechanical properties of steel at elevated temperatures

These equations are very useful when one is interested in the analysis of steel structures subjected to fire.

In the codes of practice for steel structures subjected to fire, strength curves are generally provided for structural steel work at elevated temperatures. In these curves the strain at which the strength is assessed is an important parameter. For example the BS: 5950 part 8 has used 1.5% strain as the strain limit as against 2% for Eurocode 3 Part10. A lower strain of 0.5% may be used for columns or components with brittle fire protection materials.

4.3 Fire resistant steel

Fire safety in steel structures could also be brought about by the use of certain types of steel, which are called ‘Fire Resistant Steels (FRS)’. These steels are basically thermo-mechanically treated (TMT) steels which perform much better structurally under fire than the ordinary structural steels. These steels have the ferrite – pearlite microstructure of ordinary structural steels but the presence of Molybdenum and Chromium stabilises the microstructure even at 600°C. The composition of fire resistant steel is presented in Table.4

Table 4 Chemical composition of fire resistant steel

| | C | Mn | Si | S | P | Mo + Cr |
|-------------------|----------|-----------|-----------|----------|----------|----------------|
| FRS | ≤0.20% | ≤1.50% | ≤0.50% | ≤0.040% | ≤0.040% | ≤1.00% |
| Mild Steel | ≤0.23% | ≤1.50% | ≤0.40% | ≤0.050% | ≤0.050% | - |

The fire resistant steels exhibit a minimum of two thirds of its yield strength at room temperature when subjected to a heating of about 600°C. In view of this, there is an innate protection in the steel for fire hazards. Fire resistant steels are weldable without pre-heating and are commercially available in the market as joists, channels and angles.

4.4 Fire engineering of steel structures

The study of steel structures under fire and its design provision are known as ‘fire engineering’. The basic idea is that the structure should not collapse prematurely without giving adequate time for the occupants to escape to safety. As briefly outlined earlier, there are two ways of providing fire resistance to steel structures. In the first method of fire engineering, the structure is designed using ordinary temperature of the material and then the important and needed members may be insulated against fire. For the purpose of fire protection the concept of ‘*section factor*’ is used. In the case of fire behaviour of structures, an important factor which affects the rate of heating of a given section, is the section factor which is defined as the ratio of the perimeter of section exposed to fire (H_p) to that of the cross-sectional area of the member (A). As seen from Fig. 11, a section, which has a low (H_p/A) value, would normally be heated at a slower rate than the one with high (H_p/A) value, and therefore achieve a higher fire resistance. Members with low H_p/A value would require less insulation. For example sections at the heavy end (deeper sections) of the structural range have low H_p/A value and hence they have slow heating rates. The section factor can be used to describe either protected or unprotected steel. The section factor is used as a measure of whether a section can be used without fire protection and also to ascertain the amount of protection that may be required. Typical values of H_p of some fire-protected sections are presented in Fig. 12.

In the second method of fire engineering, the high temperature property of steel is taken into account in design using the Equations 2,3 and 4. If these are taken into account in the design for strength, at the rated elevated temperature, then no insulation will be required for the member. The structural steel work then may be an unprotected one.

There are two methods of assessing whether or not a bare steel member requires fire protection.

The first is the load ratio method which compares the 'design temperature' i.e. maximum temperature experienced by the member in the required fire resistance time, and the 'limiting temperatures', which is the temperature at which the member fails.

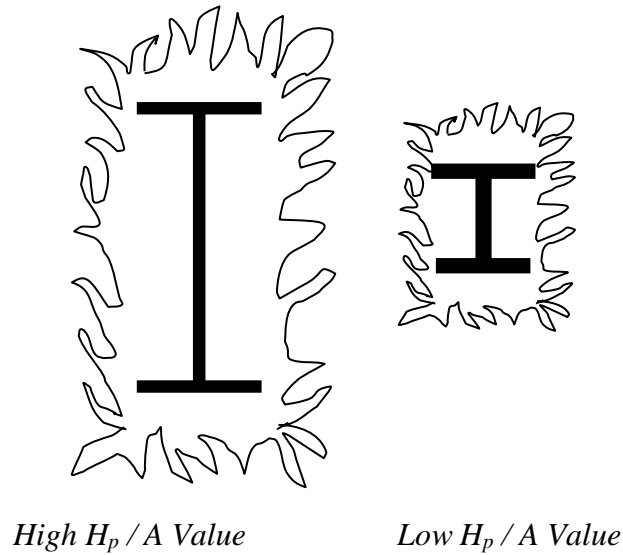

Fig.11 The section factor concept

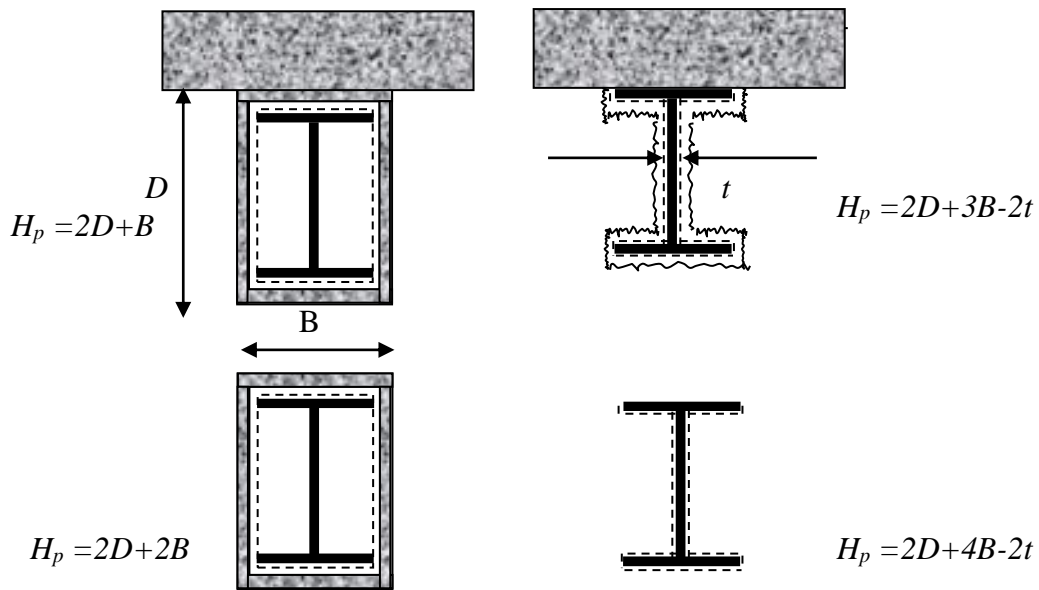

Fig. 12 Some typical values of H_p of fire protected steel sections

The limiting temperatures for various structural members are available in the relevant codes of practice. The load ratio may be defined as:

$$\text{Load ratio} = \frac{\text{Load applied at the fire limit state}}{\text{Load causing the member to fail under normal conditions}}$$

If the load ratio is less than 1, then no fire protection is required. In the second method, which is applicable to beams, the moment capacity at the required fire resistance time is compared with the applied moment. When the moment capacity under fire exceeds the applied moment, no fire protection is necessary

4.5 Methods of fire protection

Fire protection methods are basically dependent on the fire load, fire rating and the type of structural members. The commonly used fire protection methods are briefly enumerated below.

Spray protection: The thickness of spray protection depends on the fire rating required and size of the job. This is a relatively low cost system and could be applied rapidly. However due to its undulating finish, it is usually preferred in surfaces, which are hidden from the view.

Board protection: This is effective but an expensive method. Board protection is generally used on columns or exposed beams. In general no preparation of steel is necessary prior to applying the protection.

Intumescent coating: These coatings expand and form an insulating layer around the member when the fire breaks out. This type of fire protection is useful in visible steelwork with moderate fire protection requirements. This method does not increase the overall dimensions of the member. Certain thick and expensive intumescent coatings will give about 2-hour fire protection. But these type of coatings require blast cleaned surface and a priming coat.

Concrete encasement: This used to be the traditional fire proofing method but is not employed in structures built presently. The composite action of the steel and concrete can provide higher load resistance in addition to high fire resistance. However this method results in increases dead weight loading compared to a protected steel frame. Moreover, carbonation of concrete aids in encouraging corrosion of steel and the presence of concrete effectively hides the steel in distress until it is too late.

5.0 FATIGUE OF STEEL STRUCTURES

A component or structure, which is designed to carry a single monotonically increasing application of static load, may fracture and fail if the same load or even smaller load is, applied cyclically a large number of times. For example a thin rod bent back and forth beyond yielding fails after a few cycles of such repeated bending. This is termed as the 'fatigue failure'. Examples of structures, prone to fatigue failure, are bridges, cranes, offshore structures and slender towers, etc., which are subjected to cyclic loading.

The fatigue failure is due to progressive propagation of flaws in steel under cyclic loading. This is partially enhanced by the stress concentration at the tip of such flaw or crack. As we can see from Fig. 13, the presence of a hole in a plate or simply the presence of a notch in the plate has created stress concentrations at the points 'm' and 'n'.

The stress at these points could be three or more times the average applied stress. These stress concentrations may occur in the material due to some discontinuities in the material itself. These stress concentrations are not serious when a ductile material like steel is subjected to a static load, as the stresses redistribute themselves to other adjacent elements within the structure.

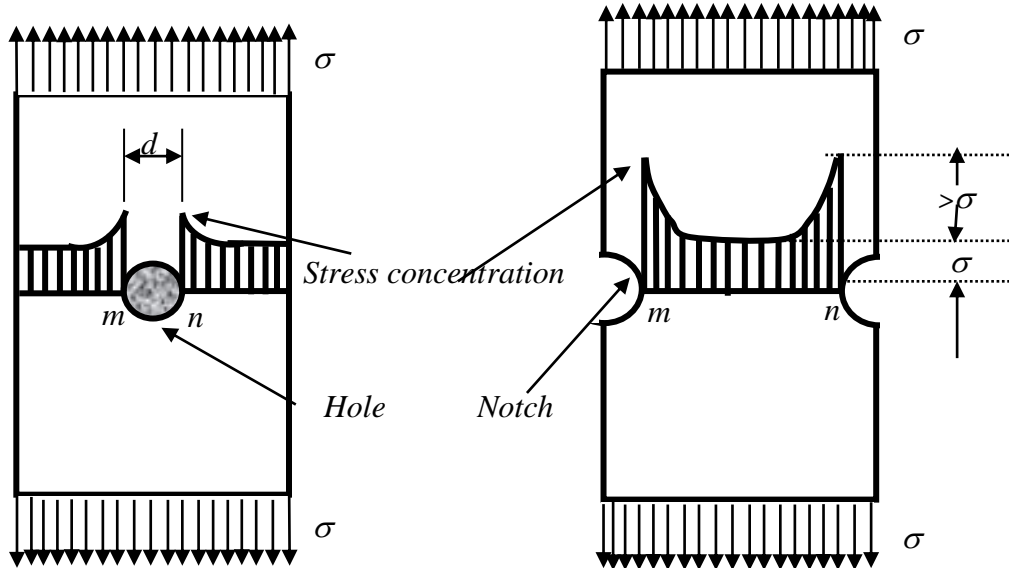

Fig. 13 Stress concentrations in the presence of notches and holes

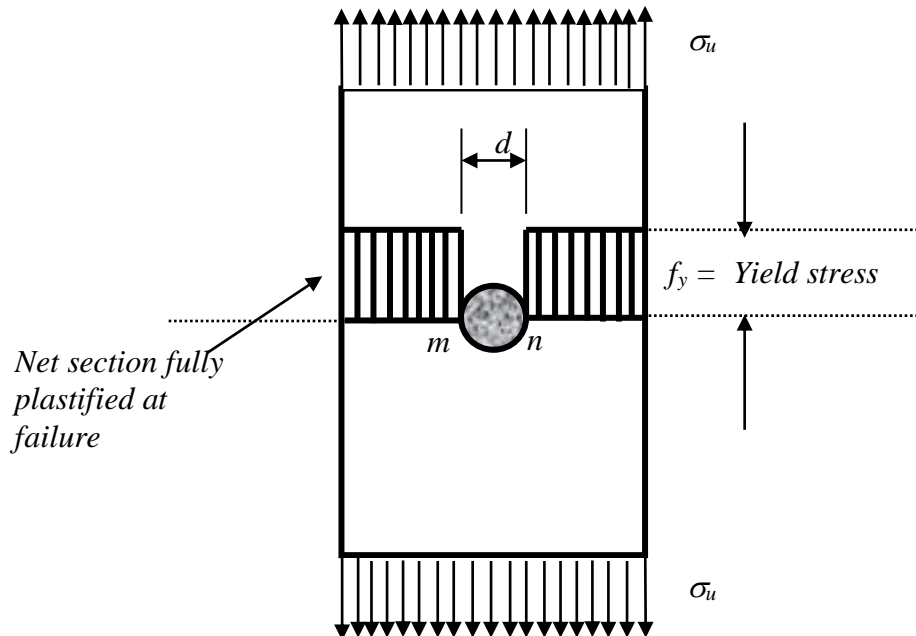

Fig. 14 Stress pattern at the point of static failure

At the time of static failure, the average stress across the entire cross section would be the yield stress as shown in Fig.14. However when the load is repeatedly applied or the load

fluctuates between tension and compression, the points m, n experience a higher range of stress reversal than the applied average stress. These fluctuations involving higher stress ranges, cause minute cracks at these points, which open up progressively and spread with each application of the cyclic load and ultimately lead to rupture.

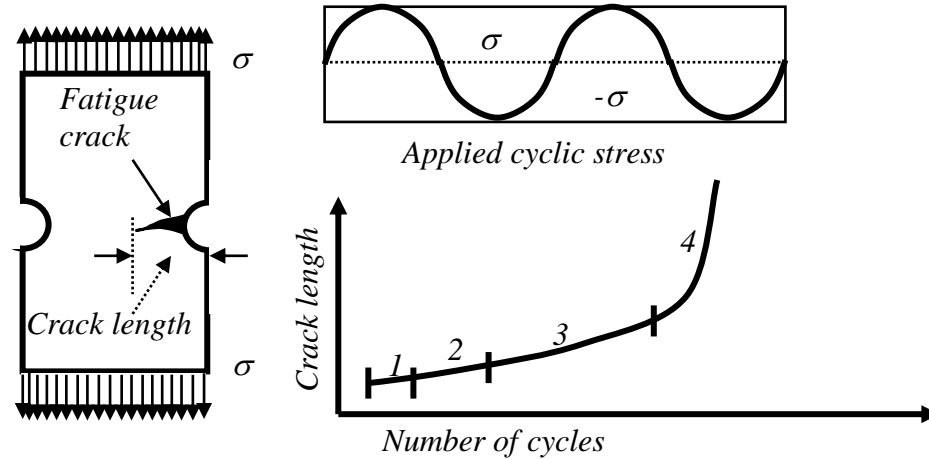

Fig.15 Crack growth and fatigue failure under cyclic load

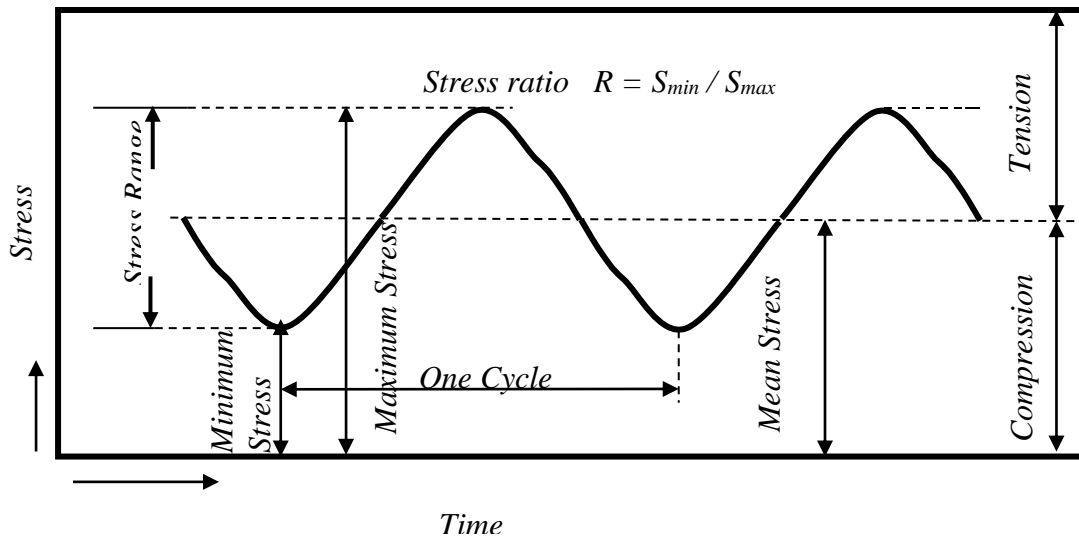

Fig.16 Terminology used in fatigue resistant design of structural steel work

The fatigue failure occurs after four different stages, namely:

1. Crack initiation at points of stress concentration
2. Crack growth
3. Crack propagation
4. Final rupture

The development of fatigue crack growth and the various stages mentioned above are symbolically represented in Fig. 15. Fatigue failure can be defined as the number of

cycles and hence time taken to reach a pre-defined or a threshold failure criterion. Fatigue failures are classified into two categories namely the high cycle and low cycle fatigue failures, depending upon the number of cycles necessary to create rupture. Low cycle fatigue could be classified as the failures occurring in few cycles to a few tens of thousands of cycles, normally under high stress/ strain ranges. High cycle fatigue requires about several millions of cycles to initiate a failure. The type of cyclic stresses applied on structural systems and the terminologies used in fatigue resistant design are illustrated in Fig. 16.

5.1 S-N Curves and fatigue resistant design

The common form of presentation of fatigue data is by using the S-N curve, where the total cyclic stress (S) is plotted against the number of cycles to failure (N) in logarithmic scale. A typical S-N curve is shown in Fig. 17.

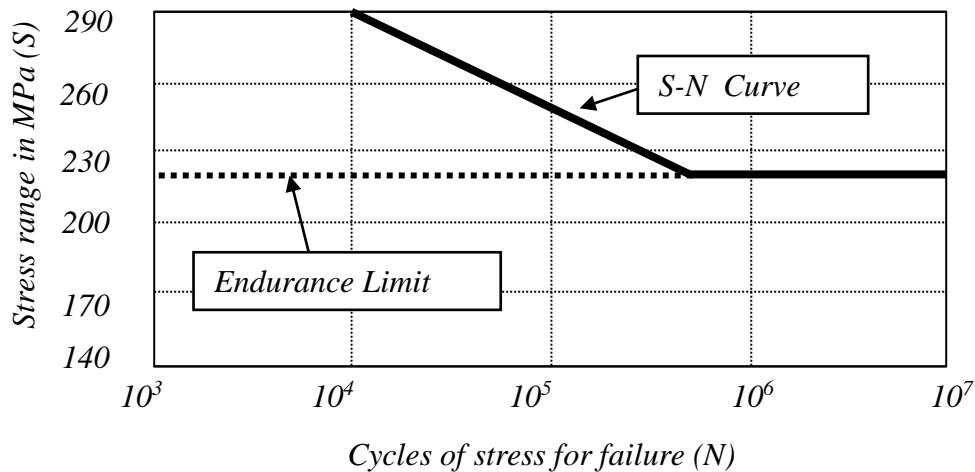

Fig. 17 S-N diagram for fatigue life assessment

It is seen from Fig. 17 that the fatigue life reduces with respect to increase in stress range and at a limiting value of stress, the curve flattens off. The point at which the S-N curve flattens off is called the 'endurance limit'. To carry out fatigue life predictions, a linear fatigue damage model is used in conjunction with the relevant S-N curve. One such fatigue damage model is that postulated by Wohler as shown in Fig. 17. The relation between stress and the number of cycles for failure could be written as

$$\log N = \log C - m \log S \quad (5)$$

where 'N' is the number of cycles to failure, 'C' is the constant dependant on detailing category, 'S' is the applied constant amplitude stress range and 'm' is the slope of the S-N curve. For the purpose of design it is more convenient to have the maximum and minimum stresses for a given life as the main parameters. For this reason the modified Goodman diagram, as shown in Fig. 18, is mostly used. The maximum stresses are plotted in the vertical ordinate and minimum stresses as abscissa. The line OA represents alternating cycle ($R = -1$), line OB represents pulsating cycle ($R = 0$) and OC the static

load ($R = 1$). Different curves for different values of fatigue life 'N' can be drawn through point 'C' representing the fatigue strength for various numbers of cycles. The vertical distance between any point on the 'N' curve and the 45° line OC through the origin represents the stress range. As discussed earlier, the stress range is the important parameter in the fatigue resistant design. Higher the stress range a component is subjected to, lower would be its fatigue life and lower the stress range, higher would be the fatigue life.

5.2 Fatigue resistant design of structural steel work

It is seen from practical experiences that most of the fatigue failures are due to improper detailing rather than an inadequate design of the member for strength. Let us consider a lap joint using fillet weld as shown in Fig. 19. From the schematic stress diagram it is seen that the fillet weld toe becomes a point of stress concentration. As a result, if the joint is subjected to cyclic loads, the weld toe experiences a variation of larger stress range compared to the parent member. Hence, a crack may be initiated at the weld toe where there is stress concentration. This stress concentration can be eliminated by using a butt welded joint, ground flush with the plate surface.

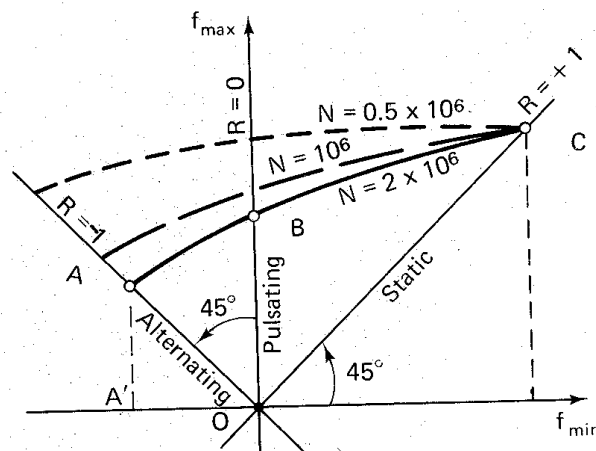

Fig.18 Modified Goodman diagram for fatigue resistant design of steel structures

It becomes very important to avoid any local structural discontinuities and notches by good design and this is the most effective means of increasing fatigue life. Where a structure is subjected to fatigue, it is important that welded joints are considered carefully. Indeed, weld defects and poor weld details are the major contributors of fatigue failures. The fatigue performance of a joint can be enhanced by the use of techniques such as proper weld geometry, improvements in welding methods and better weld quality control using non-destructive testing (NDT) methods. The following general points are important for the design of a welded structure with respect of fatigue strength: (a) use butt welds instead of fillet welds (b) use double sided welds instead of single sided fillet welds (c) pay attention to the detailing which may cause stress concentration and (d) in very important details subjected to high cyclic stresses use any non-destructive testing (NDT) method to ensure defect free details. From the point of

view of fatigue design, the codes of practice classify various structural joints and details depending upon their vulnerability to fatigue cracks. For example, IS: 1024 classifies the detailing in the structural steel work in seven classes viz., A, B, C, D, E, F and G depending upon their vulnerability to stress concentrations. A typical detailing classified as 'E' is shown in Fig. 20. This class 'E' applies to members fabricated with full cruciform butt welds. Similarly, the class 'F' is applicable for members with 'T' type full penetration butt welds, members connected by transverse load – carrying fillet welds and members with stud shear connectors in composite sections. Such a typical detailing is shown in Fig. 21. The IS: 1024 (1968) provides allowable stress tables for all the classifications from A-G for different stress ratios of $R = F_{min}/F_{max}$ and different life (number of cycles N). Using these tables the allowable stress for a given life time may be linearly interpolated and the life time for a given allowable stress could be logarithmically interpolated. The accuracy of any fatigue life calculation is highly dependent on a good understanding of the expected loading sequence during the whole life of a structure. Once a global load pattern has been developed, then a more detailed inspection of particular area of a structure where the effects of loading may be more important called the 'hot spot stresses' which are basically the areas of stress concentrations.

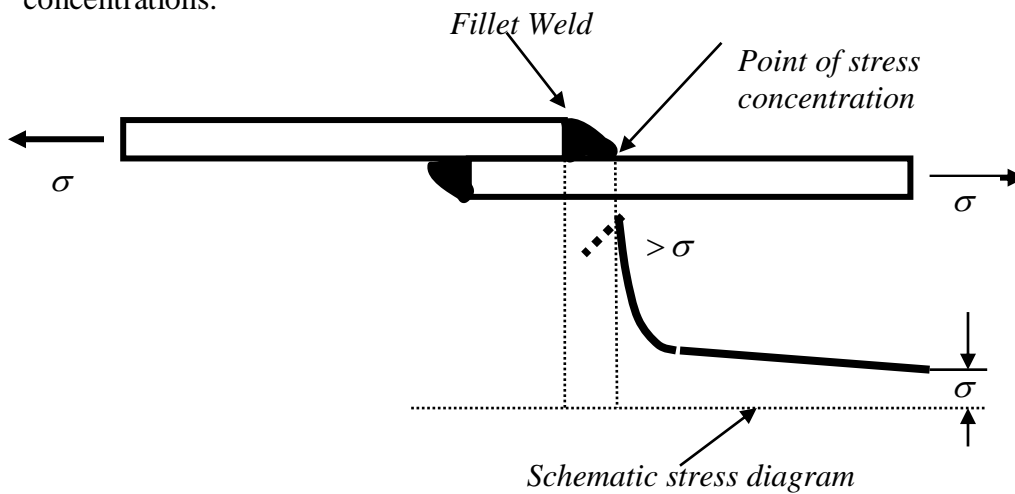

Fig. 19 Stress concentration at the weld toe

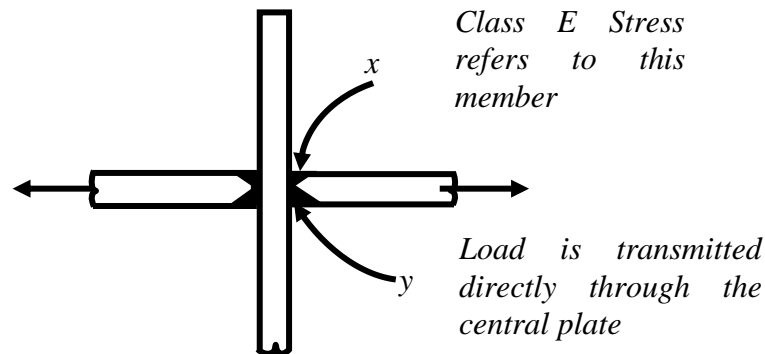

Fig. 20 Class 'E' detailing according to IS: 1024 (1968)

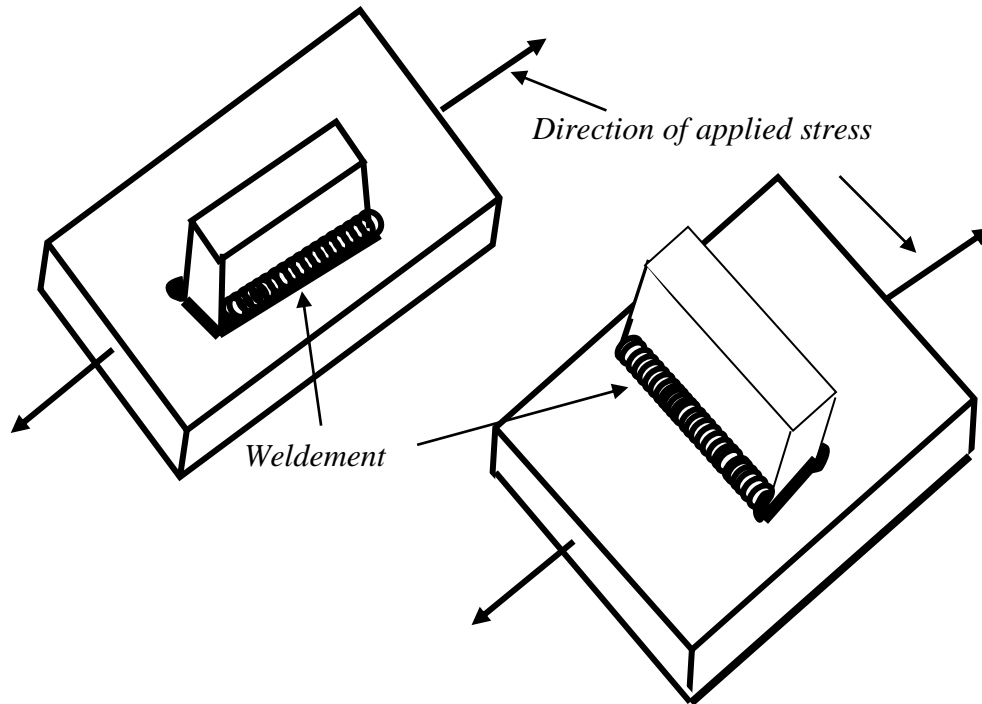

Fig. 21 Class 'F' detailing according to IS: 1024 (1968)

6.0 SUMMARY

In this chapter the three important aspects of structural steel work viz. the corrosion, fire protection, fatigue behaviour have been reviewed. Aspects of corrosion, its mechanism and means of protection of structural steel work have been discussed briefly. It was shown that the risk to structural steel work by corrosion could be effectively handled using the presently available technology. Aspects of fire resistant design of steel structures were also reviewed. Finally the fatigue failure of structural steel work and the importance of detailing in its prevention have been discussed.

7.0 FURTHER READING

1. Adams P.F., Krentz H.A. "Limit State Design in Structural Steel – SI Units", Canadian Institute of Steel Construction (1979).
2. Doran D.K., "Construction Materials Reference Book", Butterworth Heinemann (1995).
3. Graham W. Owens and Peter R. Knowles, "Steel Designer's Manual", ELBS fifth Edition (1994).
4. Jack C. McCormac, "Structural Steel Design", Harper & Row Publishers, NY (1981).
5. John H. Bickford , " An introduction to the design and behaviour of bolted joints", (Second Edition), Marcel Dekker Inc., NY, (1990)
6. Radaj D, "Design and analysis of fatigue resistant welded structures", Abington Publishing, (1990).
7. IS: 1024 – 1968, Code of Practice for use of welding in bridges and structures subjected to dynamic loading, Bureau of Indian Standards.