

1 HISTORICAL DEVELOPMENT AND CHARACTERISTICS OF STRUCTURAL STEELS

1.0 INTRODUCTION

According to published literature, iron was primarily used for making weapons in ancient times. The great Indian epics, Ramayana and Mahabharatha, contain evidence that our forefathers knew about the usage of iron long before many other countries knew about it! Iron is thus very native to India! This is a logical conclusion because, our war-centric epics date back to several thousand years BC. The backdrop of these epics revolves around the eastern, central and southern parts of our country, where there are still huge deposits of iron ore. Not only during Vedic times but also in medieval times, our country has been an epitome of iron wonders. A review in the subsequent sections shows that in modern times too, our country has good examples of construction in steel.

Under compelling reasons, both economic and strategic, the western countries brought about the industrial revolution during the last century. Possibly because our country was under the colonial rule at that time and also due to a mood of complacency, our country failed to catch up with the western industrial revolution. During the last 50 years our country has continued to lag behind in infrastructure development and consequently poor consumption of iron and steel. Published studies by the Steel Construction Institute (U.K) have established that countries which have a higher rate of growth in Gross Domestic Product (GDP), have proportionately higher consumption of iron and steel. Soon after independence, our country had to gear itself to meet the demands for development and industrial growth and in the first few Five Year plans made reasonable strides in the area of production and usage of iron and steel.

Due to various reasons, steel consumption in our country has been stagnating during the past 2-3 years. Further, steel industry is facing stiff global competition through imports. There is also considerable under utilisation of installed capacity for steel production. For sustenance of steel industry, extensive usage of structural steel in the construction sector is an important requirement. Our country has to live up to the global competition as we have done in Information Technology!

In this chapter, we will first discuss about the historical development of iron and steel in the world and India. Since the present days are the days of inter-disciplinary approach to engineering solutions, we will first review the metallurgical aspect of structural steels and then proceed to discuss, the mechanical properties of steel, which are very relevant to structural designers. The approach of treating the metallurgical and mechanical aspects of steel together helps the designer in structural steelwork, to use steel effectively in tune with its performance requirement. Later, we will briefly review the production process of steel, which gives an idea about the different structural steels being produced. We will also review the special variety of steels (such as stainless steels and cold rolled steels).

© Copyright reserved

2.0 HISTORICAL DEVELOPMENT

Ancient Hittis were the first users of iron some 3 to 4 millenniums ago. Their language was altered to Indo – European and they were native of Asia Minor. There is archaeological evidence of usage of iron dating back to 1000 BC, when Indus valley, Egyptians and probably the Greeks used iron for structures and weapons. Thus, iron industry has a long ancestry. Wrought iron had been produced from the time of middle ages, if not before, through the firing of iron ore and charcoal in “bloomery”. This method was replaced by blast furnaces from 1490 onwards. With the aid of water-powered bellows, blast furnaces were used for increased output and continuous production. A century later, rolling mill was introduced for enhanced output. The traditional use of wrought iron was principally as dowels and ties to strengthen masonry structures. As early as 6th century, iron tie-bars had been incorporated in arches of Haghia Sophia in Istanbul. Renaissance domes often relied on linked bars to reinforce their bases. A new degree of sophistication was reached in the 1770 in the design of Pantheon in Paris.

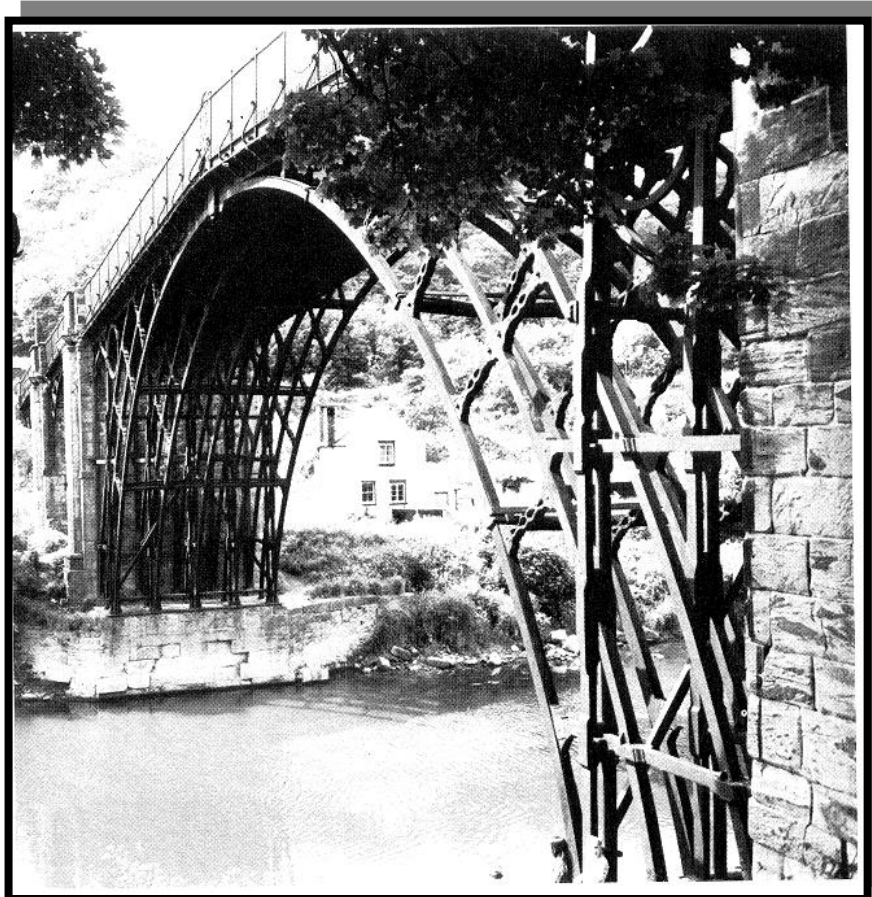

*Fig. 1 World's first cast iron bridge - Coalbrookdale bridge at Shropshire, U.K
(Source: John H. Stephens, The Guinness book of Structures (Bridges, towers, tunnels, dams), 1976)*

Till the 18th century the output of charcoal fired blast furnaces was almost fully converted to wrought iron production, with about 5% being used for casting. The most obvious cast iron items were the cannons in the early 16th century. Galleries for the House of Commons in England were built of slender cast iron columns in 1706 and cast iron railings were erected around St. Paul's Cathedral in London in 1710. Abraham Darby discovered smelting of iron with coke in 1709. This led to further improvements by 1780s when workable wrought iron was developed. The iron master Henry Cort took out two patents in 1783-84, one for a coal-fired refractory furnace and the other for a method of rolling iron into standard shapes. Without the ability to roll wrought iron (into standard shapes), structural advances, which we see today, would never have taken place.

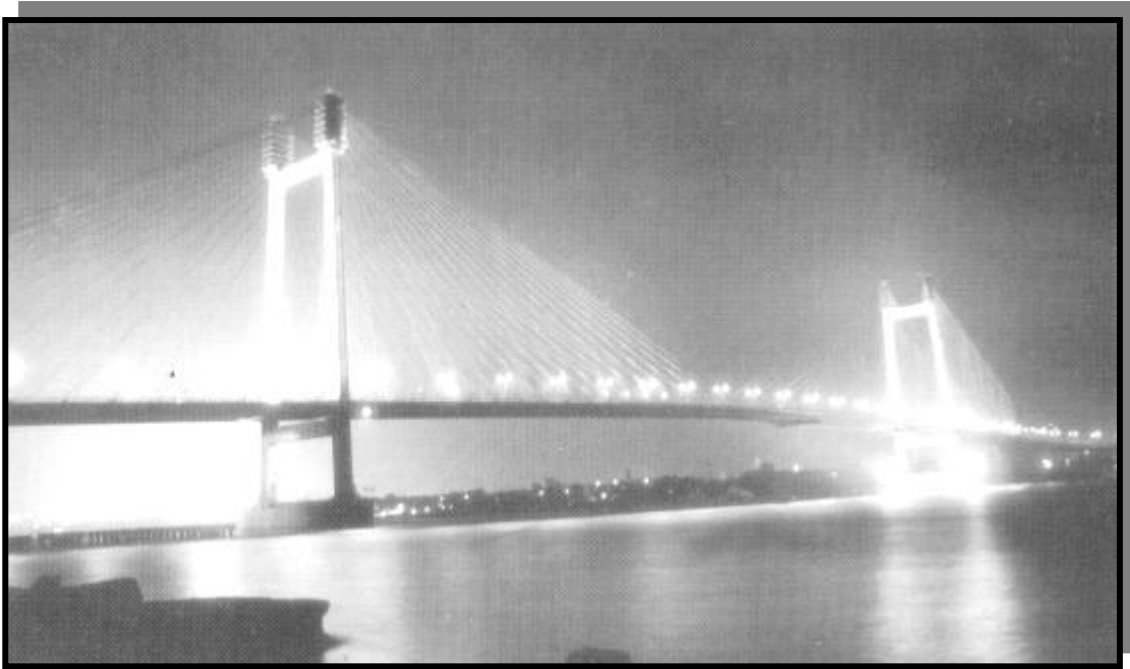

Fig.2 The second Hooghly cable stayed bridge

Technological revolution, industrial revolution and growth of mills continued in the West and this increased the use of iron in structures. Large-scale use of iron for structural purposes started in the Europe in the later part of the 18th Century. The first of its kind was the 100 feet Coalbrookdale arch bridge in England (Fig.1), constructed in 1779. This was a large size cast iron bridge. The use of cast iron as a primary construction material continued up to about 1840 and then onwards, there was a preference towards wrought iron, which is more ductile and malleable. The evolution of making better steel continued with elements like manganese being added during the manufacturing process. In 1855, Sir Henry Bessemer of England invented and patented the process of making steel. It is also worth mentioning that William Kelly of USA had also developed the technique of making steel at about the same time. Until the earlier part of the 19th century, the 'Bessemer process' was very popular. Along with Bessemer process, Siemens Martin process of open-hearth technique made commercial steel popular in the 19th century. In the later part of the 19th century and early 20th century, there had been a

revolution in making better and newer grades of steel with the advent of newer technologies. This trend has continued until now and today we have very many variety of steels produced by adding appropriate quantities of alloying elements such as carbon, manganese, silicon, chromium, nickel and molybdenum etc to suit the needs of broad and diverse range of applications.

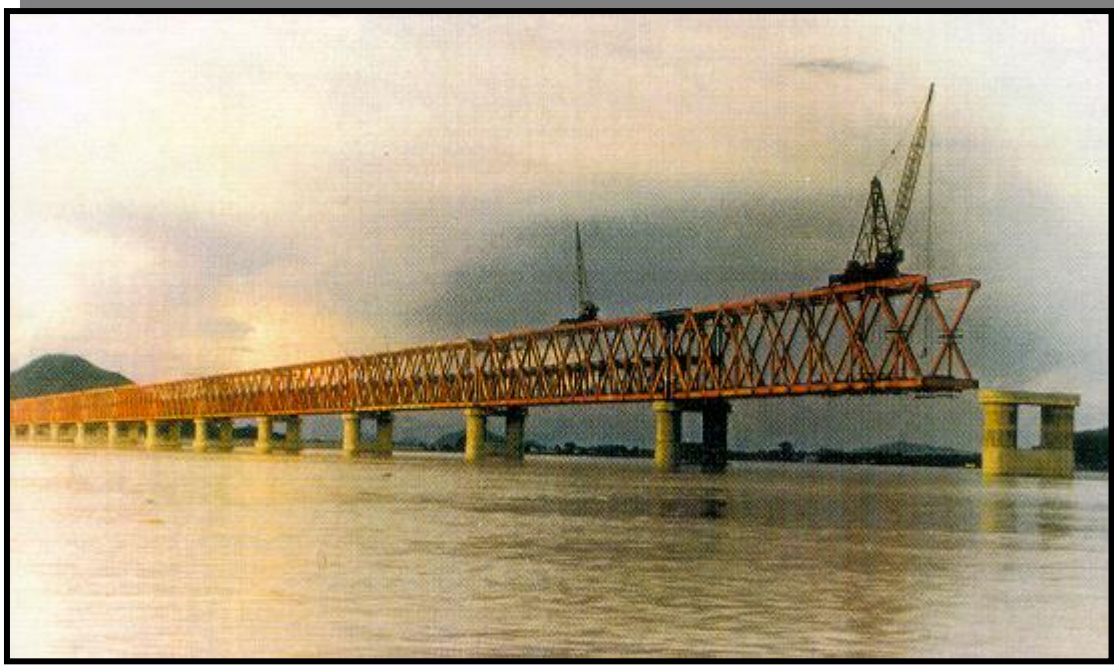

Fig. 3 Jogighopa Road-cum-rail bridge across the river Brahmaputra

2.1 Historical development of Iron and Steel in India

As mentioned earlier there are numerous examples of usage of iron in our country in the great epics Ramayana and Mahabharatha. However the archaeological evidence of usage of iron in our country, is from the Indus valley civilisation. There are evidences of iron being used as weapons and even some instruments. The iron pillar made in the 5th century (standing till today in Mehrauli Village, Delhi, within a few yards from Kutub Minar) evokes the interest and excitement of all the enlightened visitors. Scientists describe this as a "Rustless Wonder". Another example in south India is the Iron post in Kodachadri Village in Karnataka, which has 14 metres tall "Dwaja Stamba" reported to have remained without rusting for nearly 1½ millennia. The exciting aspects of these structures is not merely the obvious fact of technological advances in India at that time, but in the developments of techniques for handling, lifting, erecting and securing such obviously heavy artefacts. These two are merely examples besides several others. The usage of iron in wars during Moghul era of the history is well documented. India under the British rule experienced growth of iron and steel possibly because of the fallout of technological development of steel in the U.K. We can see several steel structures in public buildings, railway stations and bridges, which testifies the growth of steel in the

colonial past. The “*Rabindra Sethu*” Howrah Bridge in Calcutta stands testimony to a marvel in steel. Even after its service life, Howrah Bridge today stands as a monument. The recent example is the Second Hooghly cable stayed bridge at Calcutta (Fig. 2), which involves 13,200 tonnes of steel. Similarly the Jogighopa rail-cum-road bridge across the river Brahmaputra (Fig. 3) is an example of steel intensive construction, which used 20,000 tonnes of steel. There are numerous bridges, especially for railways built, exclusively using steel.

As far as production of steel in India is concerned, as early as in 1907, Jamsetji Nusserwanji Tata set up the first steel manufacturing plant at Jamshedpur. Later Pandit Jawaharlal Nehru realised the potential for the usage of steel in India and authorised the setting up of major steel plants at Bhilai, Rourkela and Durgapur in the first two five year plans. In Karnataka Sir Mokshakundam Visweswarayya established the Bhadravati Steel Plant. Today we also have a number of private sector steel plants in India. The annual production of steel in 1999-2000 has touched about 25 million tonnes and this is slated to grow at a faster rate. However, when compared to countries like USA, UK, Japan, China and South Korea the per capita consumption of steel in India is extremely low at 27.5 kg/person/year. By way of comparison, rapidly growing economies like China consume about 80 kg/person/year.

3.0 METALLURGY OF STEEL

There is a definite need for engineers involved in structural steelwork to acquaint themselves with some metallurgical aspects of steel. This will help the structural engineer to understand ductile behaviour of steel under load, welding during fabrication and erection and other important aspects of steel technology such as corrosion and fire protection. To this end, in the following sections, we shall discuss briefly the metallurgical composition of steel, its effect on heating and cooling and the effects of alloying elements such as carbon, manganese and other additive metals.

3.1 The crystal structure and the transformation of iron

Pure iron when heated from room temperature to its melting point, undergoes several crystalline transformations and exhibits two allotropic modifications such as (i) body centred cubic crystal (bcc), (ii) face centred cubic crystal (fcc) as shown in Fig.4. When iron changes from one modification to the other, it involves the ‘latent heat of transformation’. If iron is heated steadily, the rise in temperature would be interrupted when the transformation starts from one phase to the other and the temperature remains constant until the transformations are completed. The flat portion of the heating/cooling curve in Fig. 5 exemplifies this. On cooling of molten iron to room temperature, the transformations are reversed and almost at the same temperature when heated as shown in Fig. 5. Iron upto a temperature of 910°C remains as ‘*ferrite*’ or ‘ α -iron’ with ‘bcc’ crystalline structure. Iron is ferromagnetic at room temperature, its magnetism decreases with increase in temperature and vanishes at about 768°C called the *Curie point*. The iron that exists between 768°C and 910°C is called the ‘ β -iron’ with a ‘bcc’ structure. However, in the realm of metallurgy, this classification does not have much significance.

Between 910°C and 1400°C, iron transforms itself into ‘austenite’ or ‘ γ -iron’ with ‘face centred cubic’ (fcc) structure. When temperature is further increased, austenite reverts itself back to ‘bcc’ structure, called the ‘ δ -ferrite’. Iron becomes molten beyond 1539°C. The different phases of iron are summarised in Table 1.

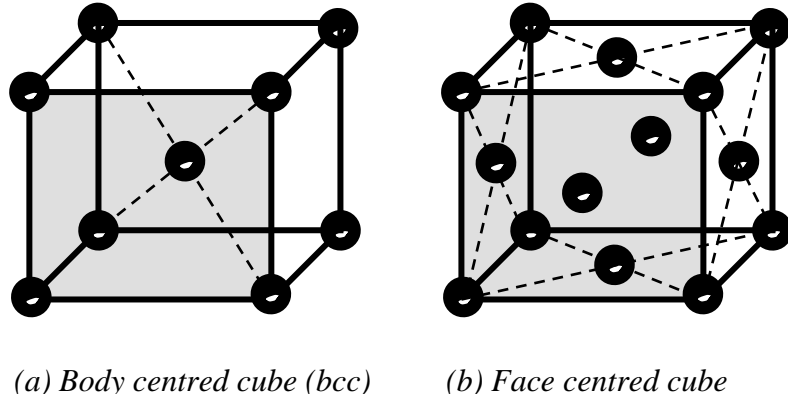

Fig.4 Crystal structure of Iron

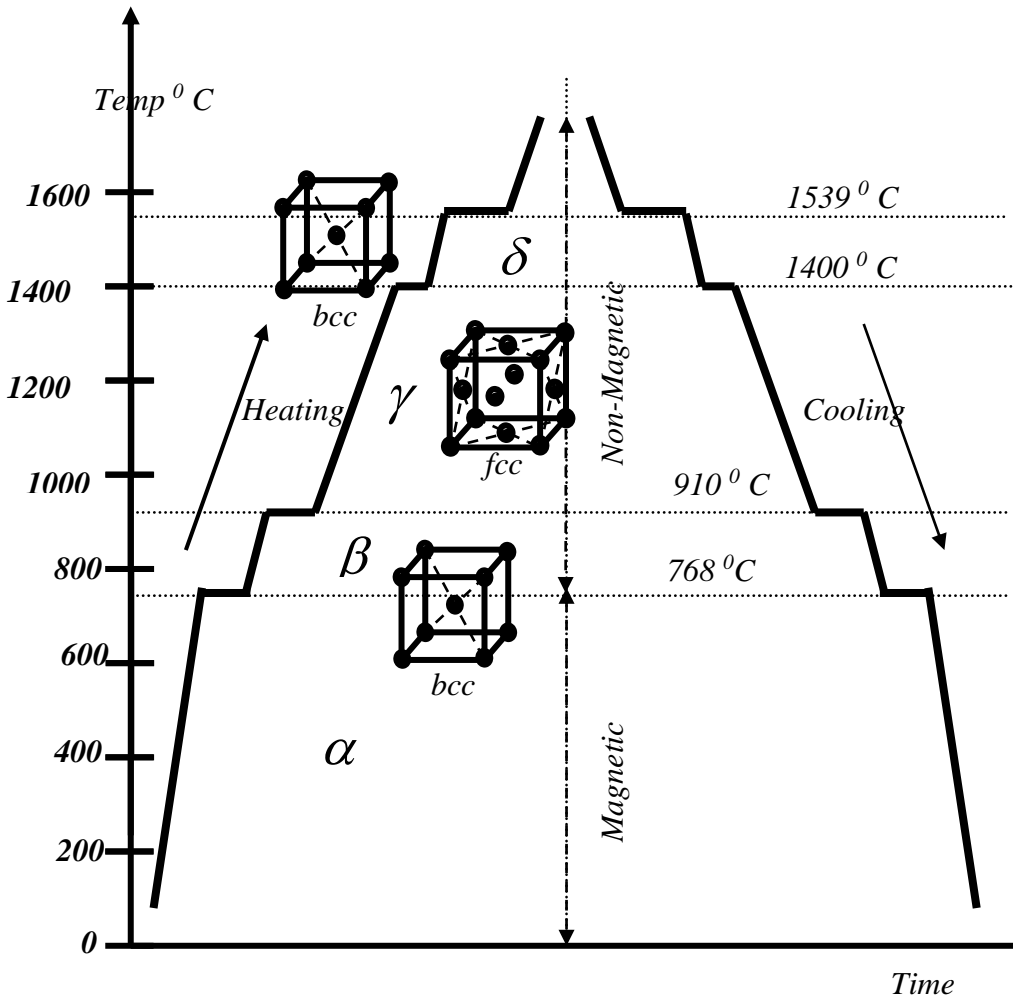

Fig.5 Allotropy of Iron

Table 1: Various forms of Iron

<i>Stable Temp. Range °C</i>	<i>Form of matter</i>	<i>Phase</i>	<i>Identification symbol</i>
>2740	Gaseous	Gas	Gas
1539-2740	Liquid	Liquid	Liquid
1400-1539	Solid	bcc	δ-ferrite
910-1400	Solid	fcc	γ-austenite
<910	Solid	bcc	α-ferrite

It is interesting to note that a given number of atoms when arranged as fcc crystals occupy slightly less volume than when arranged as bcc. Due to this reason, there would be a slight volume reduction when iron transforms itself from ferrite to austenite. As shown in Fig. 4, both bcc and fcc structures have *interstitial hole positions* (inter atomic spaces) which are at mid point of the cube for bcc and at mid point of the cube edges for fcc. In γ-iron or austenite, more volume fraction of interstitials can be accommodated than in α-iron or ferrite. Atoms of elements such as carbon, nitrogen, hydrogen and boron, whose atomic diameter is smaller, would occupy these inter atomic spaces. Such an arrangement is called an '*interstitial solid solution*' as shown in Fig. 6. In other words the solute atoms are

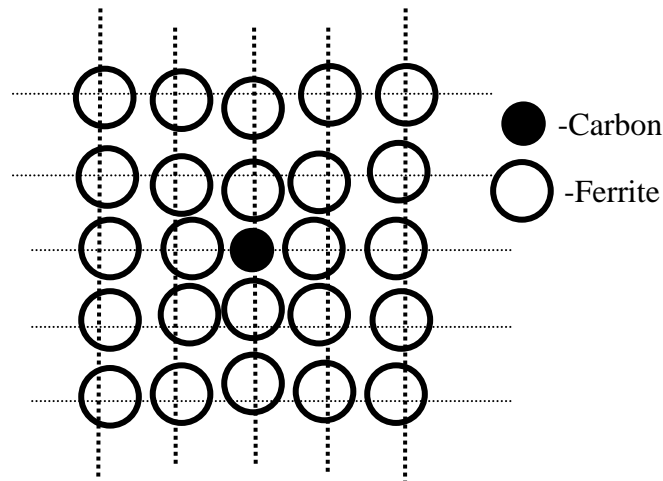

Fig.6 Interstitial solid solution of Carbon in Iron

accommodated in the interstices (inter atomic spaces) of the crystal lattice of the solvent. If we take the example of carbon, since the interstices of fcc are larger than the bcc, the solubility of carbon in austenite would be more than its solubility in ferrite.

3.2 The Iron-Carbon Constitutional Diagram

When carbon in small quantities is added to iron, '*Steel*' is obtained. Since the influence of carbon on mechanical properties of iron is much larger than other alloying elements, we would study the fundamentals of Iron-Carbon alloy in a little elaborate way. The atomic diameter of carbon is less than the interstices between iron atoms. The carbon goes into solid solution of iron. As carbon dissolves in the interstices, it distorts the original crystal lattice of iron. The iron crystals, which were centred originally at the intersection of symmetry axes of the iron crystals, get distorted as seen from Fig. 6.

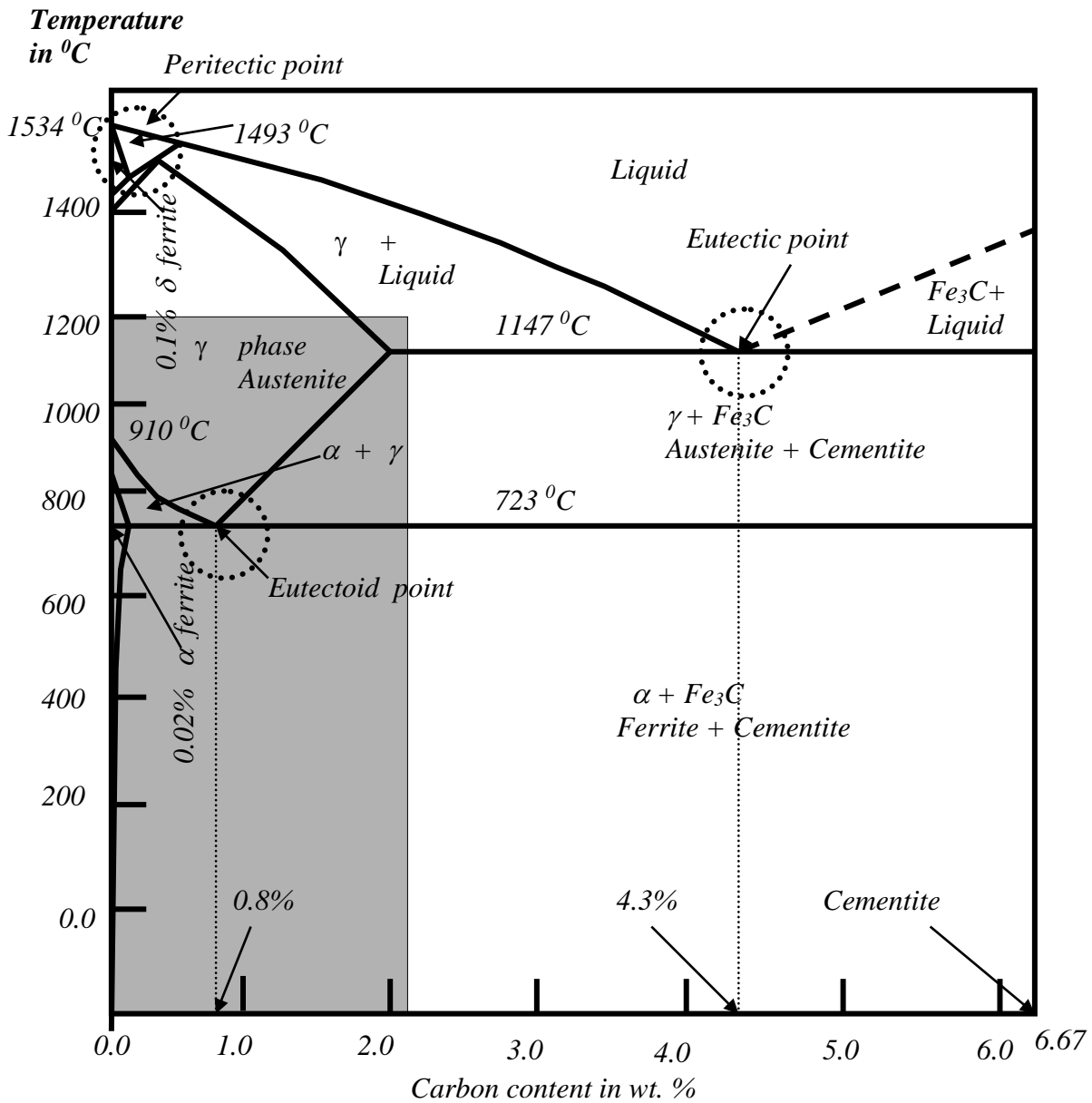

Fig.7 Iron – Iron-Carbide phase diagram

This mechanical distortion of crystal lattice interferes with the external applied strain to the crystal lattice, by mechanically blocking the dislocation of the crystal lattices. In other words, they provide mechanical strength. Obviously adding more and more carbon to iron (upto solubility of iron) results in more and more distortion of the crystal lattices and hence provides increased mechanical strength. However, solubility of more carbon influences negatively with another important property of iron called the ‘ductility’ (ability of iron to undergo large plastic deformation). The α-iron or ferrite is very soft and it flows plastically. Hence we see that when more carbon is added, enhanced mechanical strength is obtained, but ductility is reduced. Increase in carbon content is not the only way, and certainly not the desirable way to get increased strength of steels. More amount

of carbon causes problems during the welding process. We will see later, how both mechanical strength and ductility of steel could be improved even with low carbon content. The iron-carbon equilibrium diagram, which is a plot of transformation of iron with respect to carbon content and temperature, is shown in Fig.7. This diagram is also called iron-iron carbide diagram. The important metallurgical terms, used in the diagram, are presented below.

Ferrite (α): Virtually pure iron with body centred cubic crystal structure (bcc). It is stable at all temperatures upto 910°C . The carbon solubility in ferrite depends upon the temperature; the maximum being 0.02% at 723°C .

Cementite: Iron carbide (Fe_3C), a compound iron and carbon containing 6.67% carbon by weight.

Pearlite: A fine mixture of ferrite and cementite arranged in lamellar form. It is stable at all temperatures below 723°C .

Austenite (γ): Austenite is a face centred cubic structure (fcc). It is stable at temperatures above 723°C depending upon carbon content. It can dissolve upto 2% carbon. These terms are summarised in Table 2.

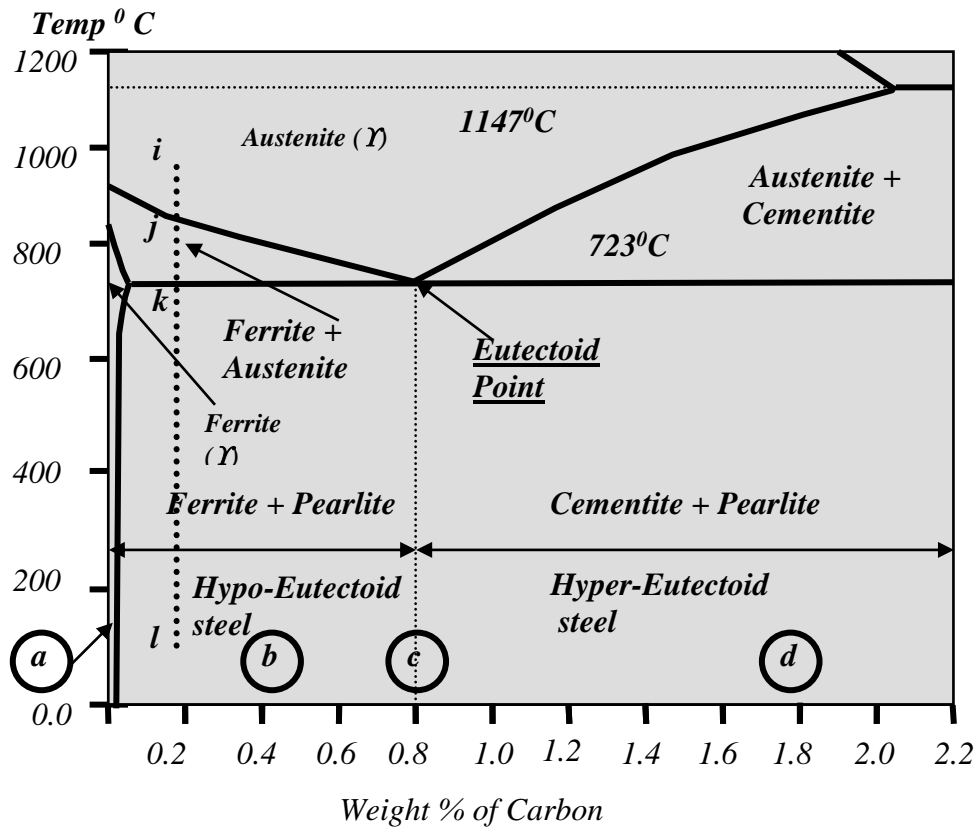

Fig.8 The Eutectoid section of the Iron – Iron Carbon phase diagram

The maximum solubility of carbon in the form of Fe_3C in iron is 6.67%. Addition of carbon to iron beyond this percentage would result in formation of free carbon or graphite in iron. At 6.67% of carbon, iron transforms completely into cementite or Fe_3C (Iron Carbide). In the iron-carbon phase diagram, there are three important points such as (1)

eutectoid point (2) eutectic point and (3) peritectic point shown in dotted circles in Fig.7. Generally carbon content in structural steels is in the range of 0.12-0.25%. Upto 2% carbon, we get a structure of ferrite + pearlite or pearlite + cementite depending upon whether carbon content is less than 0.8% or beyond 0.8%. Beyond 2% carbon in iron, cast iron is formed.

Table 2: Metallurgical terms of iron

<i>Name</i>	<i>Metallurgical term</i>	<i>% Carbon(max)</i>	<i>Crystal structure</i>
α - Iron	Ferrite	0.02	bcc
Fe ₃ C	Cementite	6.67	-
Ferrite + Cementite laminar mixture	Pearlite	0.80 (overall)	-
γ - Iron	Austenite	2.0 (depends on temperature)	fcc

3.3 The Structural Steels or ferrite – Pearlite Steels

The iron-iron carbide portion of the phase diagram that is of interest to structural engineers is shown in Fig.8. The phase diagram is divided into two parts called “hypoeutectoid steels” (steels with carbon content to the left of eutectoid point [0.8% carbon]) and “hyper eutectoid steels” which have carbon content to the right of the eutectoid point. It is seen from the figure that iron containing very low percentage of carbon (0.002%) called very low carbon steels will have 100% ferrite microstructure (grains or crystals of ferrite with irregular boundaries) as shown in Fig. 9(a). Ferrite is soft and ductile with very low mechanical strength. The microstructure of 0.20% carbon steel is shown Fig. 9(b). This microstructure at ambient temperature has a mixture of what is known as ‘pearlite and ferrite’ as can be seen in Fig. 8. Hence we see that ordinary structural steels have a *pearlite + ferrite* microstructure. However, it is important to note that steel of 0.20% carbon ends up in pearlite + ferrite microstructure, *only when it is cooled very slowly from higher temperature* during manufacture. When the rate of cooling is faster, the normal pearlite + ferrite microstructure may not form, instead some other microstructure called bainite or martensite may result.

We will consider how the microstructures of structural steel are formed by the slow cooling at 0.2% carbon. At about 900⁰C, this steel has austenite microstructure. This is shown as point ‘i’ in Fig. 8. When steel is slowly cooled, the transformation would start on reaching the point ‘j’. At this point, the alloy enters a two-phase field of ferrite and austenite. On reaching the point, ferrite starts nucleating around the grain boundaries of austenite as shown in Fig. 10(a). By slowly cooling to point 'k', the ferrite grains grow in size and diffusion of carbon takes place from ferrite regions into the austenite regions as shown in Fig. 10(b), since ferrite cannot retain carbon above 0.002% at room temperature.

At this point it is seen that a network of ferrite crystals surrounds each austenite grain. On slow cooling to point ‘l’ the remaining austenite gets transformed into ‘pearlite’ as

shown in Fig.10(c). Pearlite is a lamellar mixture of ferrite and cementite. The amount of 'pearlite' for a given carbon content is usually calculated using the lever rule assuming 0% carbon in ferrite as given below:

$$\text{Volume fraction of Pearlite} = \frac{\% \text{ of Carbon}}{0.8\% \text{ of Carbon}}$$

For example for microstructure of a 0.2% carbon steel would consist of a quarter of pearlite and three-quarters of ferrite. As explained earlier, ferrite is soft and ductile and pearlite is hard and it imparts mechanical strength to steel. The higher the carbon content, the higher would be the pearlite content and hence higher mechanical strength. Conversely, when the pearlite content increases, the ferrite content decreases and hence the ductility is reduced. The microstructure of ferrite-pearlite steels is given in Fig.9 (b). The white portion in Fig.9 (b) is ferrite and the black is pearlite. The constituents of the specimen are (pearlite + ferrite), but the phases are (ferrite + cementite). At the Eutectoid point where the carbon content is 0.8%, a fully lamellar pearlite structure is obtained as shown in Fig.9(c).

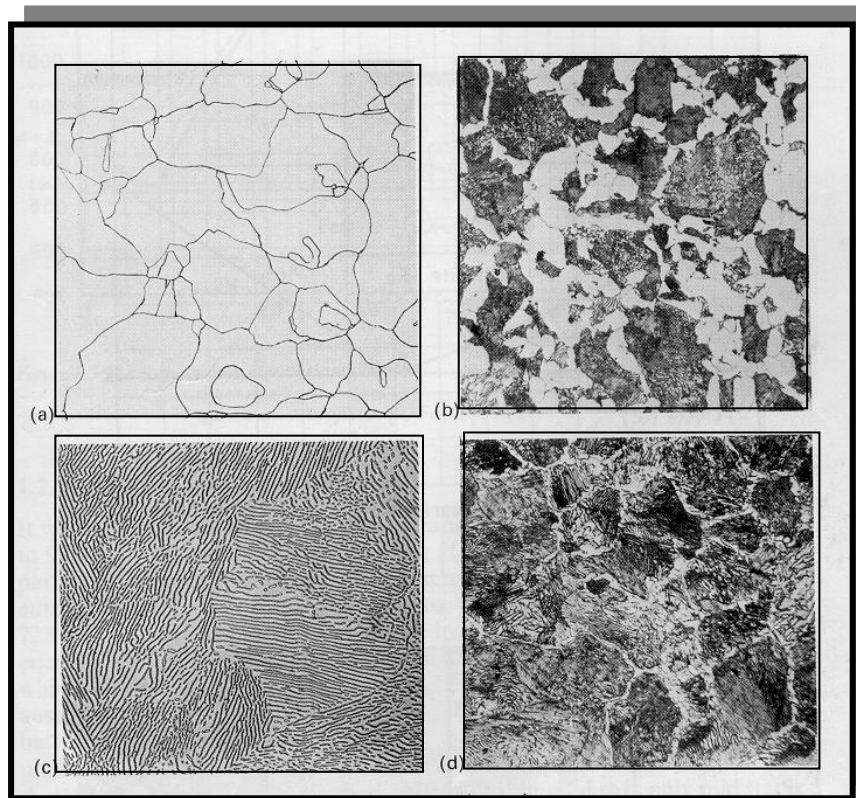

Fig.9 Microstructures of steels
(a)100% Ferrite in extra low carbon steel (b)Ferrite+Pearlite
(c) 100% Pearlite in eutectoid steel (d)Pearlite+Cementite in
hyper-eutectoid steel (Source: Thelning K.E., Steel and its heat
treatment, Butterworths, 1984.)

Note: Microstructures at (c) and (d) are not observed in structural steels.

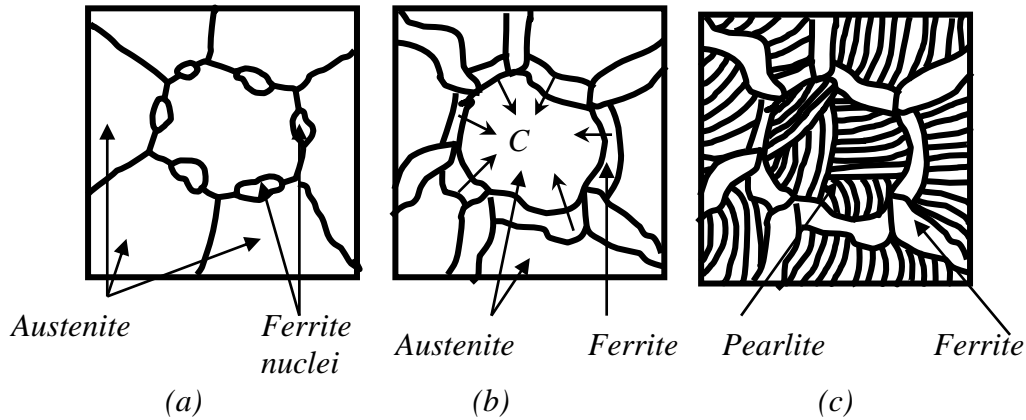

Fig.10 Different stages of formation of Pearlite

We also see from Fig.9 (d) that in the case of *hyper eutectoid steels* (steels having carbon content more than 0.8%), a microstructure of (cementite + pearlite) is obtained. Ofcourse microstructures (c) and (d) are not observed in structural steels. As mentioned earlier, increase in carbon content is not the only way to obtain increased mechanical strength. We would see in the next section, the other methods of increasing the strength of steel.

3.4 Strengthening structural steels

Cooling rate of steel from austenite region to room temperature produces different microstructures, which impart different mechanical properties. In the case of structural steels, the (pearlite + ferrite) microstructure is obtained after austenitising, by cooling it very slowly in a furnace. This process of slow cooling in a furnace is called '*annealing*'. As, mentioned in the earlier section, the formation of pearlite, which is responsible for mechanical strength, involves diffusion of carbon from ferrite to austenite. In the annealing process sufficient time is given for the carbon diffusion and other transformation processes to get completed. Hence by full annealing we get larger size pearlite crystals as shown in the cooling diagram in Fig.11. It is very important to note that the grain size of crystal is an important parameter in strengthening of steel. The yield strength of steel is related to grain size by the equation

$$f_y = f_0 + \frac{k}{\sqrt{d}} \tag{1}$$

where f_y is the yield strength, f_0 is the yield strength of very large isolated crystals (for mild steel this is taken as 5 N/mm²) and 'k' is a constant, which for mild steel is 38 N/mm^{3/2}. From Eq.1 we see that decreasing the grain size could enhance the yield strength. We will see in the following section as to how this reduction of grain size could be controlled. The grain size has an influence both in the case of mechanical strength and the temperature range of the ductile-brittle transition (temperature at which steel

would become brittle from a ductile behaviour). When steel is fully annealed, there is enough time for the diffusion or shuffling of carbon atoms and larger crystallisation is possible. However, if we increase the cooling rate, then transformation that generally needs a specified time, would not keep up with the falling temperature. When we normalise (cool in air) steel, we obtain a small increase in the ferrite content and a finer lamellar pearlite as shown in the cooling curve in Fig.11. Since pearlite is responsible for mechanical strength, decrease in its grain size we get improved mechanical strength. Hence we see that another method of increasing the mechanical strength of steel is by *normalising*.

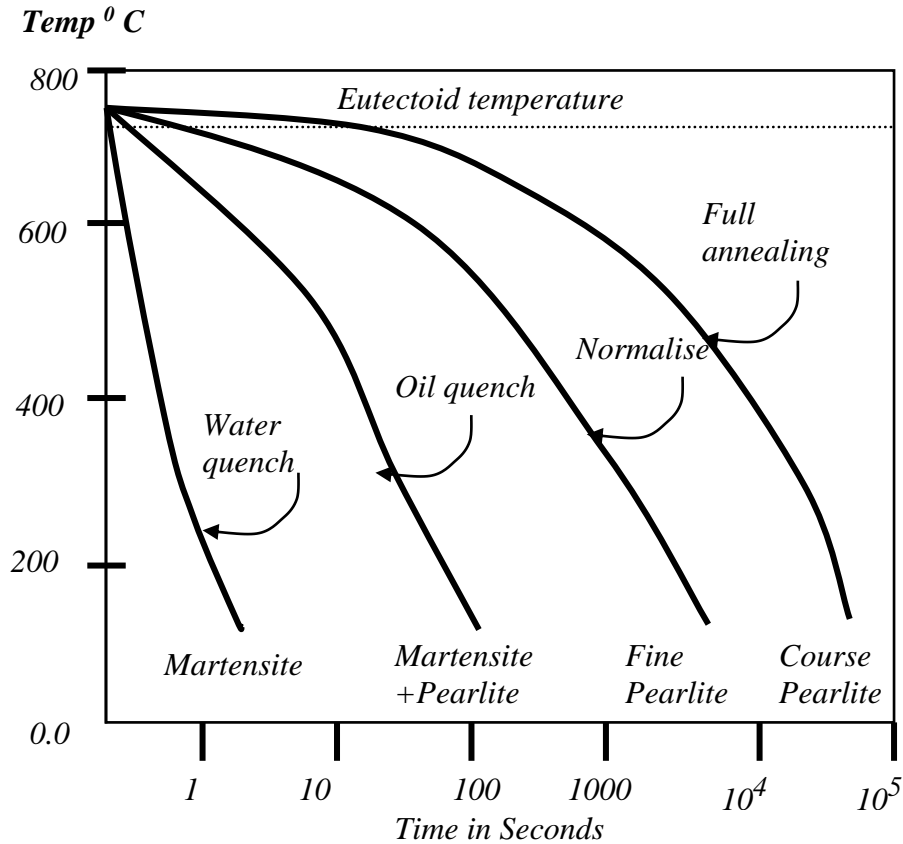

Fig.11 Variation of microstructure as a function of cooling

When structural steel sections are produced by hot rolling process, which involves the temperature range of austenite, during rolling at this high temperature, the heavy mechanical deformation results in finer size grains. In addition to that, rolling at the temperature of austenite, they are allowed to cool in air (normalising) and hence both the procedures aid the formation of smaller size crystals and hence increased mechanical strength.

3.5 Rapid cooling of steels

In the earlier section we saw that steel is made to under-cool by normalising (by giving lesser cooling time than required by the equilibrium state of the constitutional diagram), it

results in finer microstructure. However, if we cool steel very rapidly, say quenching in cold water, there is insufficient time for the shuffling or diffusion of carbon atoms and hence the formation of ferrite + pearlite is prevented. However, such a fast cooling results in 'martensite'. Slightly less rapid cooling could result in a product called 'bainite' which is dependent on the composition of steel. The formation of martensite is shown in Fig.11 by rapid cooling. It is also seen from Fig.11 that, oil quenching where cooling rate which is slightly slower, results in a mixture of martensite + pearlite. Fig.12 shows the formation of different composition for varied cooling rates. It is seen from Fig.12 that *bainite* is formed above a temperature of about 300°C and between a cooling rate of 8.4°C/sec to 0.0062°C/sec. Martensite is formed by rapid cooling rate less than 8.4°C/sec. Very slow cooling, say full annealing does not form both Martensite and Bainite. Fig.12 clearly shows that the final microstructure of steel is dependent on cooling rate.

Martensite is very hard and less ductile. Martensitic structure is not desirable in structural steel sections used in construction, because its welding becomes very difficult. However, high strength bolts and some other important accessories have predominantly martensitic structure. The hardness of martensite is a function of carbon content. When martensite is heated to a temperature of 600°C it softens and the toughness is improved. This process of reheating martensite is called *tempering*. This process of quenching and tempering results in very many varieties of steel depending upon the requirement for hardness, wear resistance, strength and toughness.

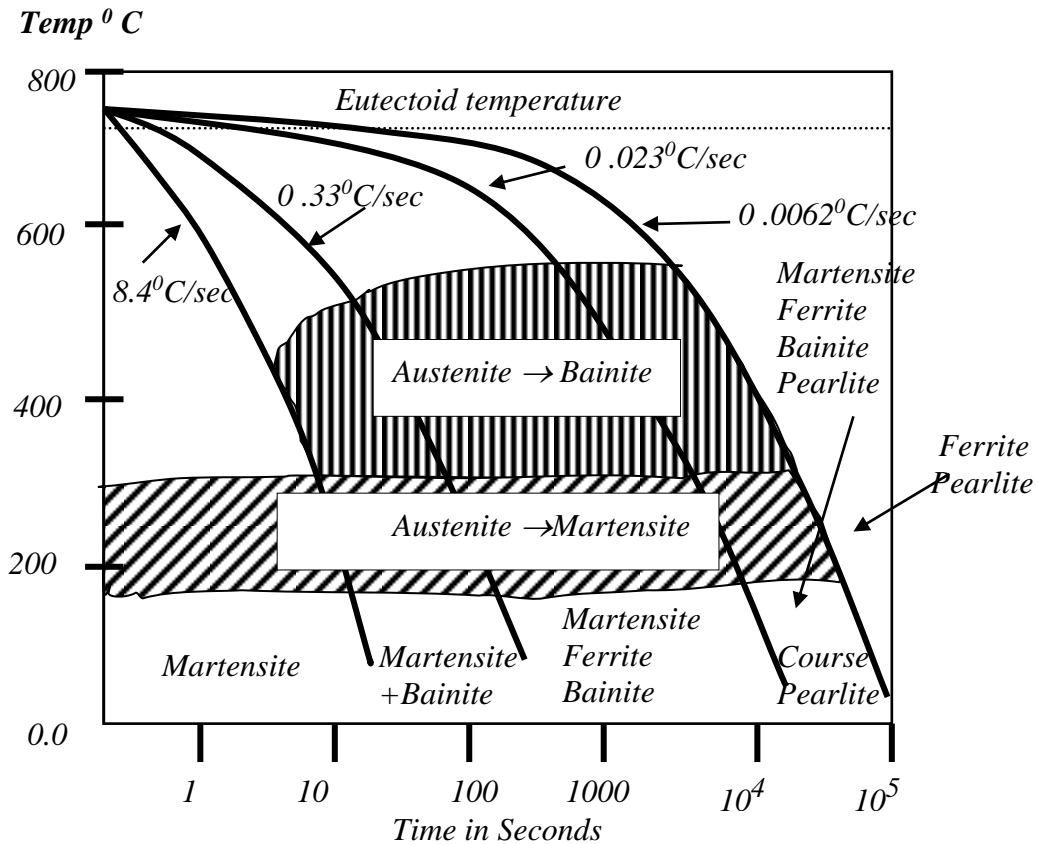

Fig.12 Rate of cooling Vs microstructure

3.6 Inclusions and alloying elements in steel

Steel contains impurities such as phosphorous and sulphur and they eventually form phosphides and sulphides which are harmful to the toughness of the steel. Hence it is desirable to keep these elements less than 0.05%. Phosphorous could be easily removed compared to sulphur. If manganese (Mn) is added to steel, it forms a less harmful manganese sulphide (MnS) rather than the harmful iron sulphide. Sometimes calcium, cerium, and other rare earth elements are added to the refined molten steel. They combine with sulphur to form less harmful elements. Steel treated this way has good toughness and such steels are used in special applications where toughness is the criteria. The addition of manganese also increases the under cooling before the start of the formation of ferrite+ pearlite. This gives fine-grained ferrite and more evenly divided pearlite. Since the atomic diameter of manganese is larger than the atomic diameter of iron, manganese exists as '*substitutional solid solution*' in ferrite crystals, by displacing the smaller iron atoms as shown in Fig.13. This improves the strength of ferrite because the distortion of crystal lattice due to the presence of manganese blocks the mechanical movement of the crystal lattices. However, manganese content cannot be increased unduly, as it might become harmful. Increased manganese content increases the formation of martensite and hence hardness and raises its ductile to brittle transition temperature (temperature at which steel which is normally ductile becomes brittle). Because of these reasons, manganese is restricted to 1.5% by weight. Based on the manganese content, steels are classified as carbon-manganese steels (Mn>1%) and carbon steels (Mn<1%). In recent years, micro alloyed steels or high strength low alloy (HSLA) steels have been developed. They are basically carbon manganese steels in which small amounts of aluminium, vanadium, niobium or other elements are used to help control the grain size.

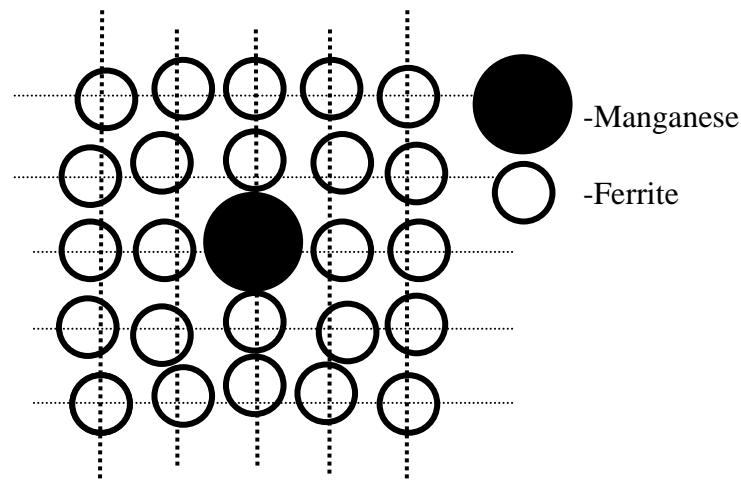

Fig.13 Substitutional solid solution of Manganese in Iron

These steels are controlled rolled and/or controlled cooled to obtain fine grain size. They exhibit a best combination of strength and toughness and also are generally weldable without precautions such as preheating or post heating. Sometimes 0.5% molybdenum is added to refine the lamellar spacing in pearlite, and to make the pearlite evenly

distributed. Today steel with still higher performance are being developed all over the world to meet the following specifications such as: (a) high strength with yield strength of 480 MPa and 690 MPa, (b) excellent weldability without any need for preheating, (c) extremely high toughness with charpy V notch values of 270 N-m @ 23°C compared with current bridge design requirement of 20 N.-m @ 23°C, and (d) corrosion resistance comparable to that of weathering steel. (The terminology used above has been discussed later in this chapter). The micro alloyed steels are more expensive than ordinary structural steels, however, their strength and performance outweighs the extra cost.

Some typical steels with their composition range and properties and their relevant codes of practice, presently produced in India, are given in Tables 3 and 4. These steels are adequate in many structural applications but from the perspective of ductile response, the structural engineer is cautioned against using unfamiliar steel grades, without checking the producer supplied properties. Weldability of steel is closely related to the amount of carbon in steel. Weldability is also affected by the presence of other elements. The combined effect of carbon and other alloying elements on the weldability is given by “carbon equivalent value (C_{eq})”, which is given by

$$C_{eq} = \%C + \%Mn/6 + (\%Cr + \%Mo + \%V)/5 + (\%Ni + \%Cu)/15$$

The steel is considered to be weldable without preheating, if $C_{eq} < 0.42\%$. However, if carbon is less than 0.12% then C_{eq} can be tolerated upto 0.45%.

Table 3 Types of steel and their relevant IS standards

Type of steel	Relevant IS standards
Structural steel	226(withdrawn),2062,3502,1977,961,8500
Steel for bars, rivets etc.	1148,1149,1570,2073,7388,4431,4432,5517
Steel for tubes and pipes	1239,1914,1978

Table 4 Chemical composition of some typical structural steels

Type of steel	Designation	IS: code	C	S	Mn	P	Si	Cr		Carbon equivalent
Standard structural steel	Fe 410A	2062	0.23	.050	1.5	.050	-	-	SK	0.42
	Fe 410B	2062	0.22	.045	1.5	.045	0.4	-	SK	0.41
	Fe 410C	2062	0.20	.040	1.5	.040	0.4	-	K	0.39
Micro alloyed high strength steel	Fe 440	8500	0.20	.050	1.3	.050	.45			0.40
	Fe540	8500	0.20	.045	1.6	.045	.45			0.44
	Fe590	8500	0.22	.045	1.8	.045	.45			0.48
K- killed steel SK- Semi Killed steel (Explained in section 6.2)										

3.7 Thermo- Mechanically Control Process (TMCP) steels

With increase in height, size and span in buildings, higher strength, longer section and heavier thickness are required for steel products to be applied. In the conventional method, increased strength is secured by increasing addition of alloying elements. However, such an addition adversely results in deterioration of weld crack resistance due to increase in carbon equivalent (C_{eq}) and lowering of weld efficiency, due to the necessity to secure high pre-heating temperatures. To cope up with such requirements, Thermo-Mechanical Control Process (TMCP) steels with yield strength of 490 Mpa are being produced in countries like Japan. TMCP allows production of steel products having higher strength but carbon equivalent similar to those of conventional steels. Even for extra heavy sections, excellent weldability and stable strength can be achieved through application of TMCP. Even for thickness greater than 40 mm TMCP steels are finding wide applications.

4.0 STAINLESS STEELS

In an iron-chromium alloy, when chromium content is increased to about 11%, the resulting material is generally classified as a stainless steel. This is because at this minimum level of chromium, a thin protective passive film forms spontaneously on steel, which acts as a barrier to protect the steel from corrosion. On further increase in chromium content, the passive film is strengthened and achieves the ability to repair itself, if it gets damaged in the corrosive environment. 'Ni' addition in stainless steel improves corrosion resistance in reducing environments such as sulphuric acid. It also changes the crystal structure from bcc to fcc thereby improving its ductility, toughness and weldability. 'Mo' increases pitting and crevice corrosion in chloride environments.

Stainless steel is attractive to the architects despite its high cost, as it provides a combined effect of aesthetics, strength and durability. Now a days, stainless steel is used extensively in building construction. For example, the worlds' tallest twin tower situated in Kuala Lumpur, Malaysia used about 4000 tonnes of stainless steel made in India! Table 5 gives typical grades of stainless steel, which are used in building construction.

Table 5 Stainless Steel grades and their usage

Grade of stainless steel	Usage
316 (18% Cr)	Profiled roofing, cladding, gutters, facades and hand railings - in highly polluted environments
304 (18% Cr-(% Ni)	Decorative elements in areas near coast line. Also for kitchen and sanitary wares - coastal and less polluted areas
430 (17% Cr)	Roofing, gutters, decorative wall tiles, hollow structural sections non-polluted environments
409 (11% Cr)	Painted roofing- non-polluted environments

Stainless steels are available in variety of finishes and it enhances the aesthetics of the structure. On Life Cycle cost Analysis (LCA), stainless steel works out to be economical

in many situations. Increased usage of stainless steel in the construction sector is expected, as awareness on LCA improves among architects and consulting engineers.

5.0 MECHANICAL PROPERTIES OF STEEL

5.1 Stress – strain behaviour: Tensile test

The stress-strain curve for steel is generally obtained from tensile test on standard specimens as shown in Fig.14. The details of the specimen and the method of testing is elaborated in IS: 1608 (1995). The important parameters are the gauge length ' L_c ' and the initial cross section area S_0 . The loads are applied through the threaded or shouldered ends. The initial gauge length is taken as $5.65 (S_0)^{1/2}$ in the case of rectangular specimen and it is five times the diameter in the case of circular specimen. A typical stress-strain curve of the tensile test coupon is shown in Fig.15 in which a sharp change in yield point followed by plastic strain is observed. When the specimen undergoes deformation after yielding, Luder's lines or Luder's bands are observed on the surface of the specimen as shown in Fig.16.

These bands represent the region, which has deformed plastically and as the load is increased, they extend to the full gauge length. This occurs over the Luder's strain of 1 to 2% for structural mild steel. After a certain amount of the plastic deformation of the material, due to reorientation of the crystal structure an increase in load is observed with increase in strain. This range is called the *strain hardening range*. After a little increase in load, the specimen eventually fractures. After the failure it is seen that the fractured surface of the two pieces form a cup and cone arrangement. This cup and cone fracture is considered to be an indication of ductile fracture. It is seen from Fig.15 that the elastic strain is up to ϵ_y followed by a yield plateau between strains ϵ_y and ϵ_{sh} and a strain hardening range start at ϵ_{sh} and the specimen fail at ϵ_{ult} where ϵ_y , ϵ_{sh} and ϵ_{ult} are the strains at onset of yielding, strain hardening and failure respectively.

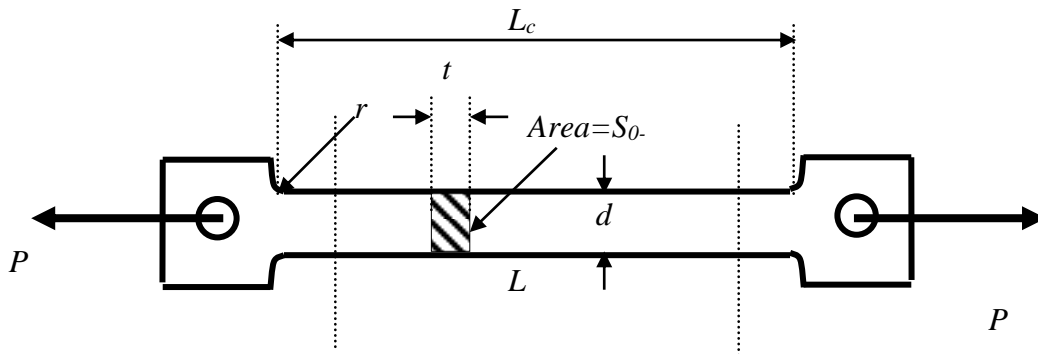

Fig.14 Standard tensile test specimen

Depending on the steel used, ϵ_{sh} generally varies between 5 to 15 ϵ_y , with an average value of 10 ϵ_y typically used in many applications. For all structural steels, the modulus of

elasticity can be taken as 205,000 MPa and the tangent modulus at the onset of strain hardening is roughly 1/30th of that value or approximately 6700 MPa.

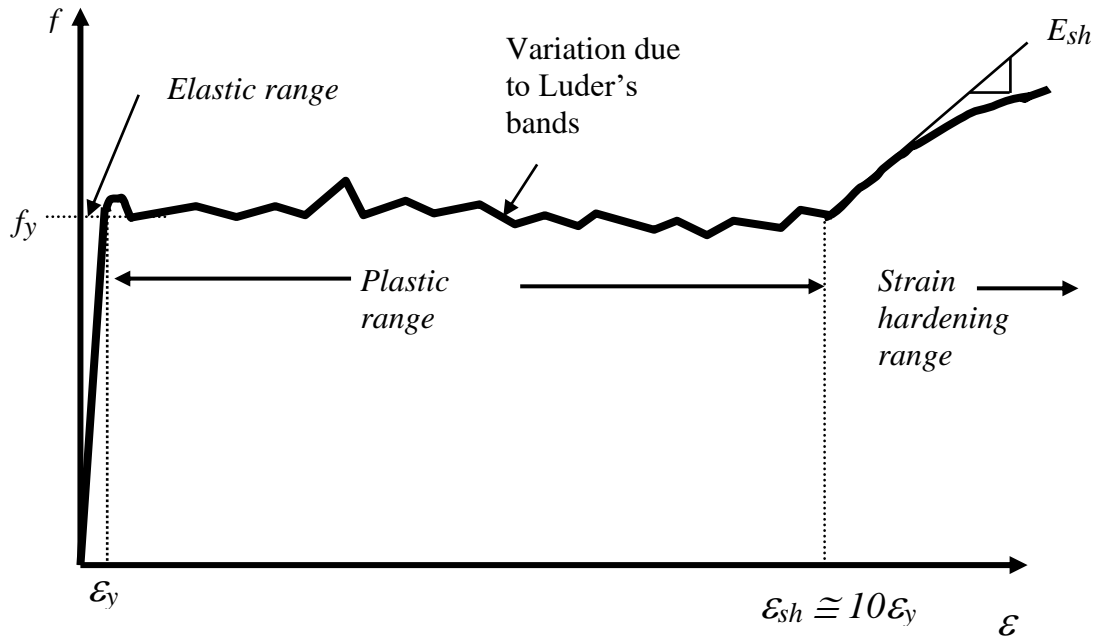

Fig.15 Stress strain curve for sharp yielding structural steels

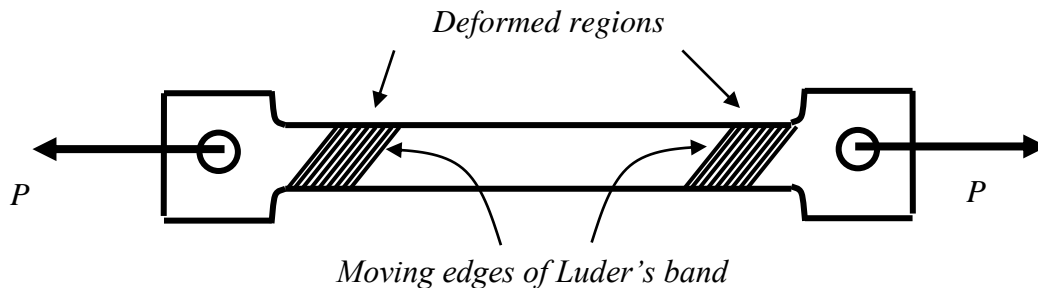

Fig.16 Luder's bands in tensile test specimen

Certain steels, due to their specific microstructure, do not show a sharp yield point but rather they yield continuously as shown in Fig. 17. For such steels the yield stress is always taken as the stress at which a line at 0.2% strain, parallel to the elastic portion, intercepts the stress strain curve. This is shown in Fig. 17.

A schematic diagram of the tensile coupon at failure is shown in Fig.18. It is seen that approximately at the mid section the area is 'S' compared to original area S_0 . Since S is the actual area experiencing the strain, the true stress is given by $f_t = P/S$, where P is the load.

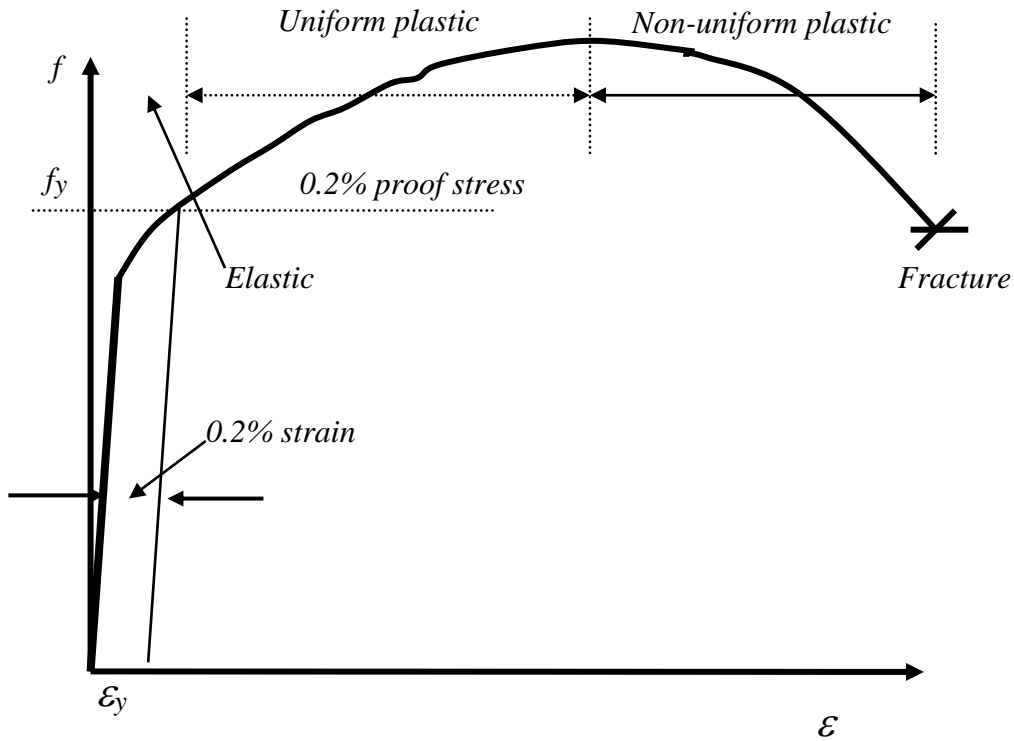

Fig. 17 Stress strain curve for continuously yielding structural steels

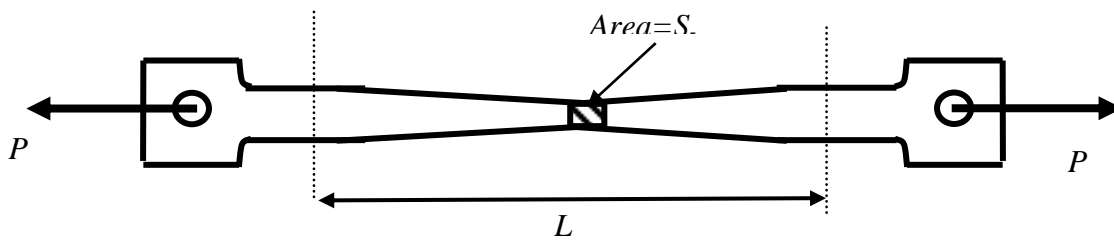

Fig.18 Tensile test specimen before rupture

However S is very difficult to evaluate compared to S_0 and the nominal stress or the engineering stress is given by $f_n = P/S_0$. Similarly, the engineering strain is taken as the ratio of the change in length to original length. However the true strain is obtained when instantaneous strain is integrated over the whole of the elongation, given by

$$\epsilon_t = \int_{L_0}^L \frac{dl}{l} = \ln\left(\frac{L}{L_0}\right) \tag{2}$$

By suitable manipulation it could be shown that

$$f_t = f_n(1 + \epsilon_n) \tag{3}$$

and similarly

$$\varepsilon_t = \ln(1 + \varepsilon_n) \tag{4}$$

where f_t and f_n are the true and nominal stresses respectively and ε_t and ε_n are the true and nominal strains respectively.

5.2 Hardness

Hardness is regarded as the resistance of a material to indentations and scratching. This is generally determined by forcing an indenter on to the surface. The resultant deformation in steel is both elastic and plastic. There are several methods using which the hardness of a metal could be found out. They basically differ in the form of the indenter, which is used on to the surface. They are presented in Table 6.

Table 6 Hardness testing methods and their indentors

	Hardness Testing Method	Indenter
(a)	Brinell hardness	Steel ball
(b)	Vickers hardness	Square based diamond pyramids of 135 ° included angle
(c)	Rockwell hardness	Diamond core with 120 ° included angle
Note: Rockwell hardness testing is not normally used for structural steels.		

In all the above cases, hardness number is related to the ratio of the applied load to the surface area of the indentation formed. The testing procedure involves forcing the indenter on to the surface at a particular load. On removal, the size of indentation is measured using a microscope. Based on the size of the indentation, hardness is worked out. For example, Brinell hardness (*BHN*) is given by the ratio of the applied load and spherical area of the indentation i.e.

$$BHN = \frac{P}{\pi(d/2) \left[D - \sqrt{D^2 - d^2} \right]} \tag{5}$$

where P is the load, D is the ball diameter, d is the indent diameter. The Vickers test gives a similar hardness value (*VHN*) as given by

$$VHN = \frac{1.854P}{L^2} \tag{6}$$

where L is the diagonal length of the indent. Some typical values of hardness of some metals are presented in Table.7.

Table 7 Hardness values of some metals

Metal	Brinell Hardness Number (BHN)	Vickers Hardness Number (VHN)
Copper (annealed)	49	53
Brass (annealed)	65	70
Steel	150-190	157-190

5.3 Effect of temperature on ductility and notch toughness

At lower temperatures below 0°C, the yield strength of steel is only marginally affected, while there is substantial reduction in ductility and toughness. The ultimate behaviour of steel progressively changes from ductile to brittle, reaching a lowest value of toughness at a threshold temperature called “Ductile-to-Brittle-Transition-Temperature” (DBTT) range. The transition temperature for structural steel is generally well below the room temperature. However, if it is near to the ambient temperature, due to the loss of ductility, engineering components may fail under service loading. This transition temperature is affected by metallurgical aspects such as grain size and also by the presence of notches. In certain instances, due to deviations in correct processing procedure when the DBTT of steel is above room temperature or the application temperature, serious failures have been observed in ships cruising through the Arctic sea, bridges in cold climates and cryogenic gas storage facilities. The Charpy “V” notch test (also known as the notch-toughness test) is used to determine the DBTT. In this test, a falling pendulum hammer fitted with a striking edge as shown in Fig.19 breaks a standard notched specimen (Fig.20). In principle, the energy absorbed by the specimen during its failure translates into a loss of potential energy of the pendulum. Thus, a rough measure of this absorbed energy can be calculated from the difference between initial height (h_1) of the pendulum when released and the maximum height (h_2) it reaches on the far side after breaking the specimen. The variation of absorbed energy with respect to temperature is shown in Fig.21. Generally, structural engineering standards and codes [IS: 1757 (1988)] will allow the use of only those steels that exhibit a minimum energy absorption capability at a pre-determined temperature say 20 N-m at 23 ±5 °C.

5.4 Strain rate effect on yield strengths of steel

Strain rate is another factor that affects the strength of steel. Typically, the tensile and yield strength increases at higher strain rates as shown in Fig.22 except that at higher temperatures the reverse is true. It may also be noted that increase in strain rate causes reduction in ductility. Consideration of this phenomenon is crucial for blast resistant design of steel structures in which very high strain rates are expected but of little practical significance in earthquake engineering applications wherein the strain rate is well within the range where f_y does not change very much.

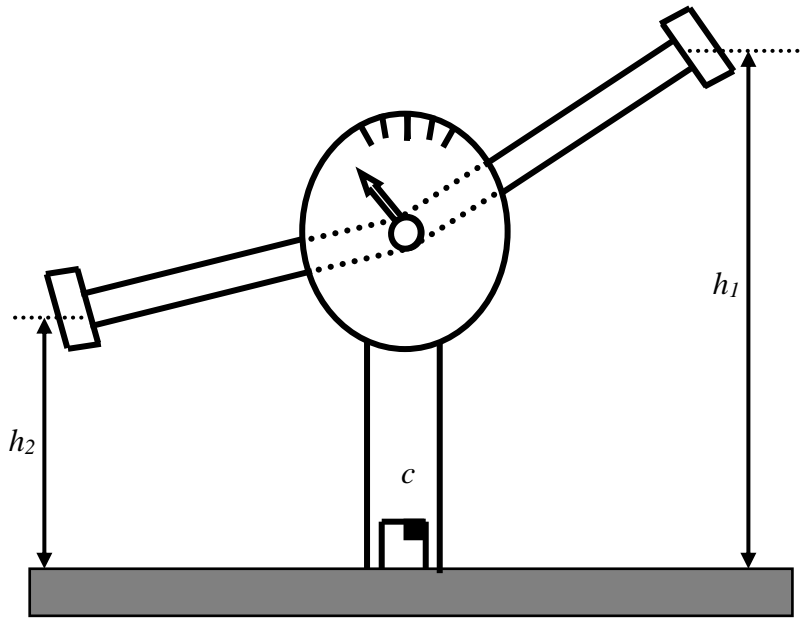

Fig. 19 Experimental set up for notch toughness test

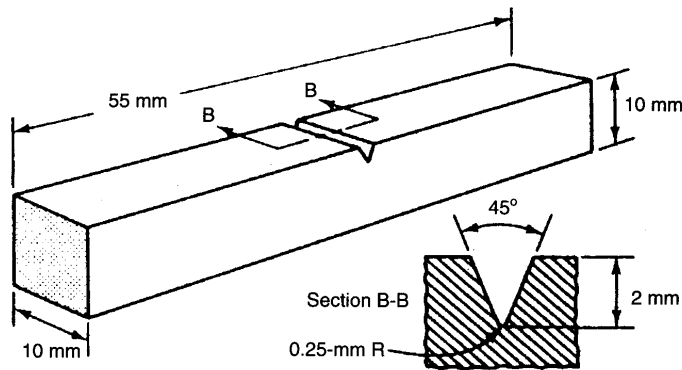

Fig. 20 Test specimen for notch toughness test

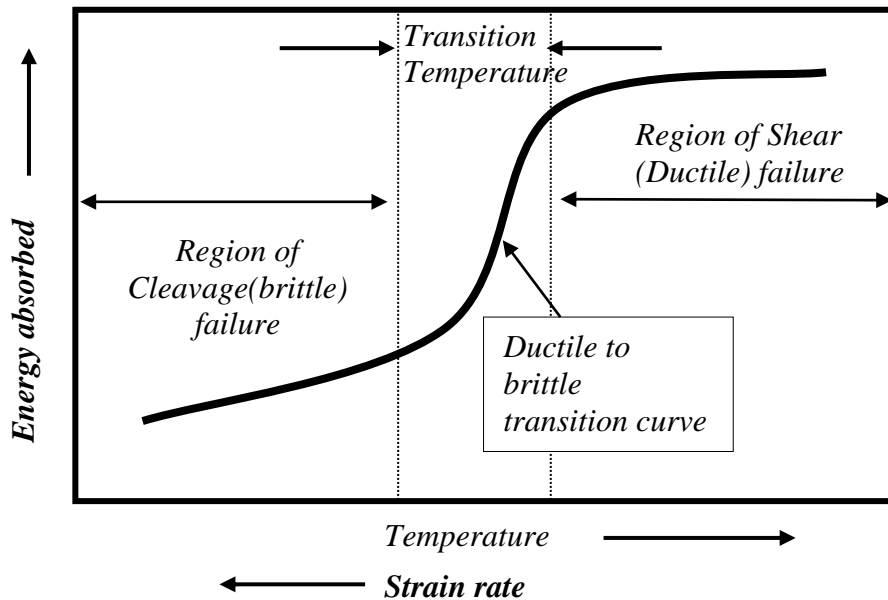

Fig.21 Effect of temperature on notch toughness of steel

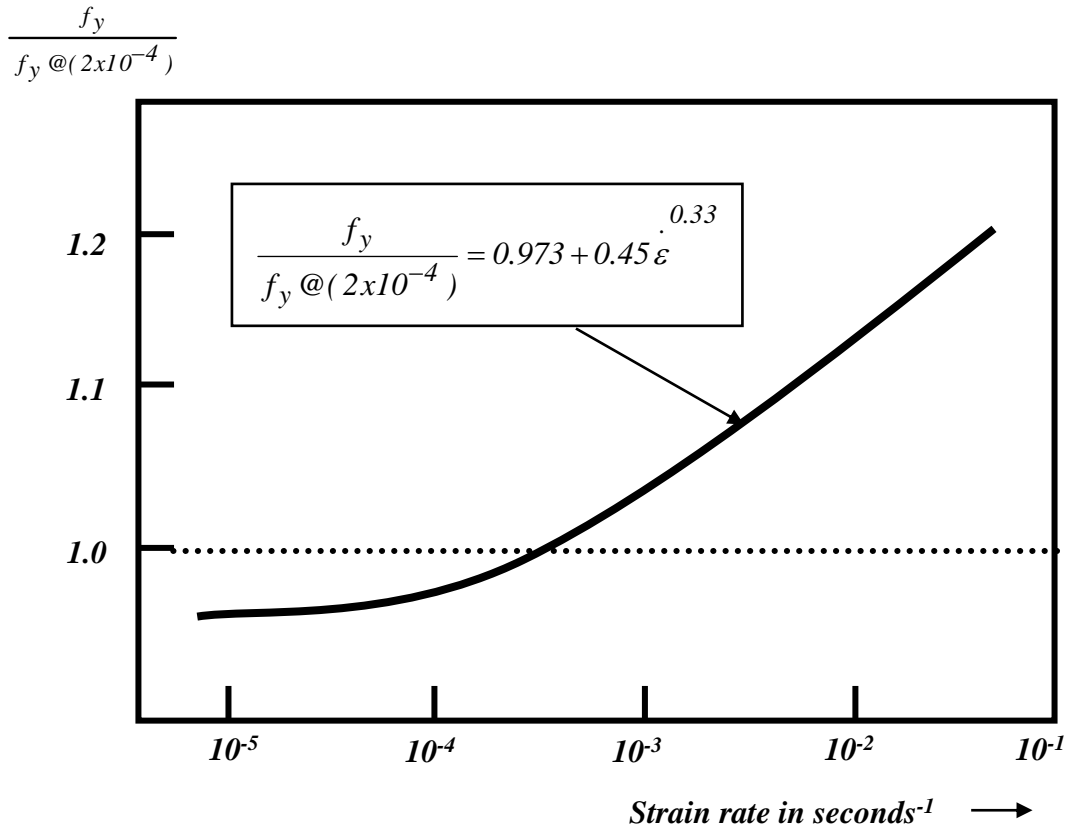

Fig.22 Strain rate effects on the yield strength of steel

Table 8 Mechanical properties of some typical structural steels

Type of steel	Designation	UTS (MPa)	Yield strength (MPa)			Elongation Gauge $5.65\sqrt{S_0}$	Charpy V - notch values Joules (min)
			Thickness (mm)				
			<20	20-40	>40		
Standard structural steel	Fe 410A	410	250	240	230	23	27
	Fe 410B	410	250	240	230	23	27
	Fe 410C	410	250	240	230	23	27
			<16	16-40	41-63		
Micro alloyed high strength steel	Fe 440	440	300	290	280	22	-
	Fe 540	540	410	390	380	20	-
	Fe 590	590	450	430	420	20	-

5.5 Mechanical properties of structural steel

Table 8 summarises some of the important mechanical properties of steel produced in India. In Table 8, the UTS represents the minimum guaranteed *Ultimate Tensile Strength* at which the corresponding steel would fail.

6.0 THE MANUFACTURING PROCESS OF STRUCTURAL STEEL

For design of structures, the structural engineer uses long and flat products. The long products include: angles; channels; joists/beams; bars and rods; cold twisted deformed (CTD) bars; thermo-mechanically treated (TMT) ribbed bars, while the flat products comprise: plates; hot rolled coils (HRC) or cold rolled coils (CRC)/sheets in as annealed or galvanised condition. The starting material for the finished products is as given below:

- Blooms in case of larger diameter/cross-section long products
- Billets in case of smaller diameter/cross-section long products
- Slabs for hot rolled coils/sheets
- Hot rolled coils in case of cold rolled coils/sheets
- Hot/Cold rolled coils/sheets for cold formed sections

6.1 Electric Arc or Induction Furnace Route for Steel Making in Mini or Midi Steel Plants

The production process depends upon whether the input material to the steel plant is steel scrap or the basic raw material i.e. iron ore. In case of former, the liquid steel is produced in Electric Arc Furnace (EAF) or Induction Furnace (IF) and cast into ingots or continuously cast into blooms/billets/slabs for further rolling into desired product. The steel mills employing this process route are generally called as mini or midi steel plants. Since liquid steel after melting contains impurities like sulphur and phosphorus beyond desirable limits and no refining is generally possible in induction furnace. The structural steel produced through this process is inferior in quality. Through refining in EAF, any desired quality (i.e. low levels of sulphur and phosphorus and of inclusion content) can be produced depending upon the intended application. Quality can be further improved by secondary refining in the ladle furnace, vacuum degassing unit or vacuum arc degassing (VAD) unit.

6.2 Iron Making and Basic Oxygen Steel Making in Integrated Steel Plants

When the starting input material is iron ore, then the steel plant is generally called the integrated steel plant. In this case, firstly hot metal or liquid pig iron is produced in a vertical shaft furnace called the blast furnace (BF). Iron ore, coke (produced by carbonisation of coking coal) and limestone [Fig. 23(a)] in calculated proportion are charged at the top of the blast furnace. Coke serves two purposes in the BF(Fig.23(b)). Firstly it provides heat energy on combustion and secondly carbon for reduction of iron ore into iron. Limestone on decomposition at higher temperature provides lime, which combines with silica present in the iron ore to form slag. It also combines with sulphur in the coke and reduces its content in the liquid pig iron or hot metal collected at the bottom of the BF.

The hot metal contains very high level of carbon content around 4%; silicon in the range of 0.5-1.2%; manganese around 0.5%; phosphorus in the range 0.03-0.12%; and somewhat higher level of sulphur around 0.05%. Iron with this kind of composition is

highly brittle and cannot be used for any practical purposes. Hot metal is charged in to steel making vessel called LD converter or the Basic Oxygen Furnace (BOF). Open-

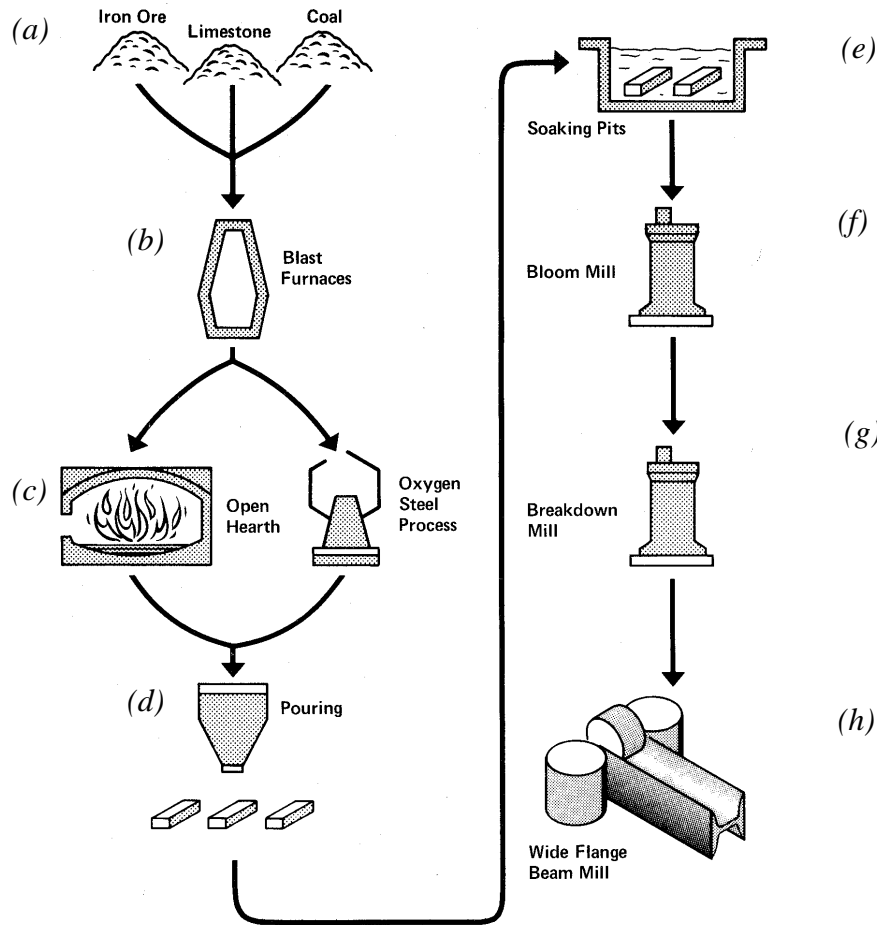

Fig.23 Schematic diagram of manufacturing of structural steel sections from Iron ore(Source: Adams P.F., Krentz H.A. and Kulak G.L., “Limit state design in structural steel – SI Units”, Canadian Institute of Steel Construction (1979).)

hearth process is also used in some plants, though it is gradually being phased out [Fig.23(c)]. Oxygen is blown into the liquid metal in a controlled manner, which reduces the carbon content and oxidises the impurities like silicon, manganese, and phosphorus. Lime is charged to slag off the oxidised impurities. Ferro Manganese (FeMn), Ferro Silicon (FeSi) and/or Aluminium (Al) are added in calculated amount to deoxidise the liquid steel, since oxygen present in steel will appear as oxide inclusions in the solid state, which are very harmful. Ferro alloy addition also helps to achieve the desired composition. Generally the structural steel contains: carbon in the range 0.10-0.25%; manganese in the range 0.4-1.2%; sulphur 0.025-0.050%; phosphorus 0.025-0.050% depending upon specification and end use. Some micro alloying elements can also be added to increase the strength level without affecting its weldability and impact toughness.

If the oxygen content is brought down to less than 30 parts per million (PPM), the steel is called fully killed, whereas if the oxygen content is around 150 PPM, then the steel is called semi-killed. During continuous casting, only killed steel is used. However, both semi-killed and killed steels are cast in the form of ingots. The present trend is to go in for casting of steel through continuous casting, as it improves the quality, yield as well as the productivity.

6.3 Casting and Primary/Finish Rolling

Liquid steel is cast into ingots [Fig.(23(d)], which after soaking at 1280-1300⁰ C in the soaking pits [(Fig.23(e)] are rolled in the blooming and billet mill into blooms/billets [(Fig.23(f)] or in slabbing mill into slabs. The basic shapes such as ingots, cast slabs, bloom and billets are shown in Fig.24. The blooms are further heated in the reheating furnaces at 1250-1280⁰ C and rolled into billets or to large structurals[(Fig.23(h)]. The slabs after heating to similar temperature are rolled into plates in the plate mill. Even though the chemical composition of steel dictates the mechanical properties, its final mechanical properties are strongly influenced by rolling practice, finishing temperature, and cooling rate and subsequent heat treatment.

The slabs or blooms or the billets can directly be continuously cast from the liquid state and thereafter are subjected to further rolling after heating in the reheating furnaces.

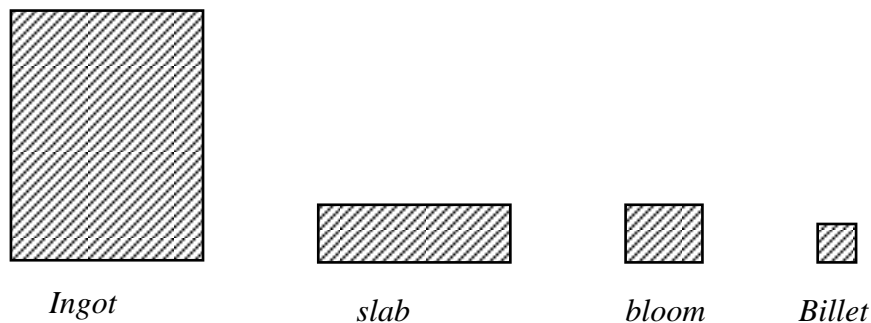

Fig. 24 Basic shapes and their relative proportions

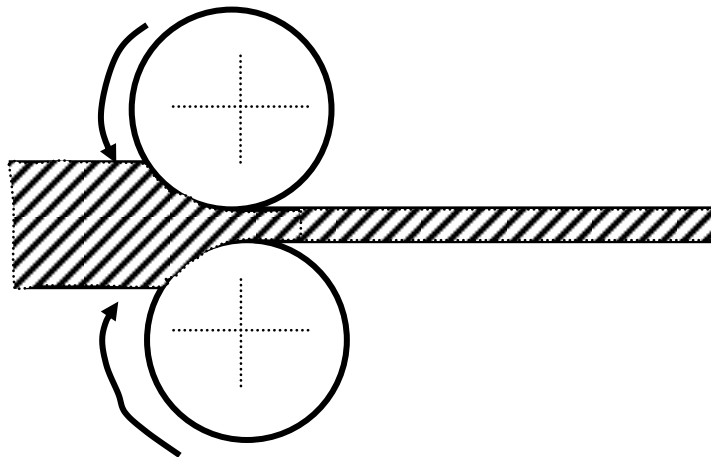

Fig.25 Primary rolls for plates

In the hot rolling operation the material passes through two rolls where the gap between rolls is lower than the thickness of the input material. The material would be repeatedly passed back and forth through the same rolls several times by reducing the gap between them during each pass. Plain rolls (Fig.25) are used for flat products such as plate, strip and sheet, while grooved rolls (Fig. 26) are used in the production of structural sections, rails, rounded and special shapes. The rolling process, in addition to shaping the steel into the required size, improves the mechanical properties by refining the grain size of the material.

Final rolling of structurals, bars/rods and HRC/CRC or sheet product is done in respective mills. In case of cold rolled sheets/coils, the material is annealed and skin passed to provide it the necessary ductility and surface finish

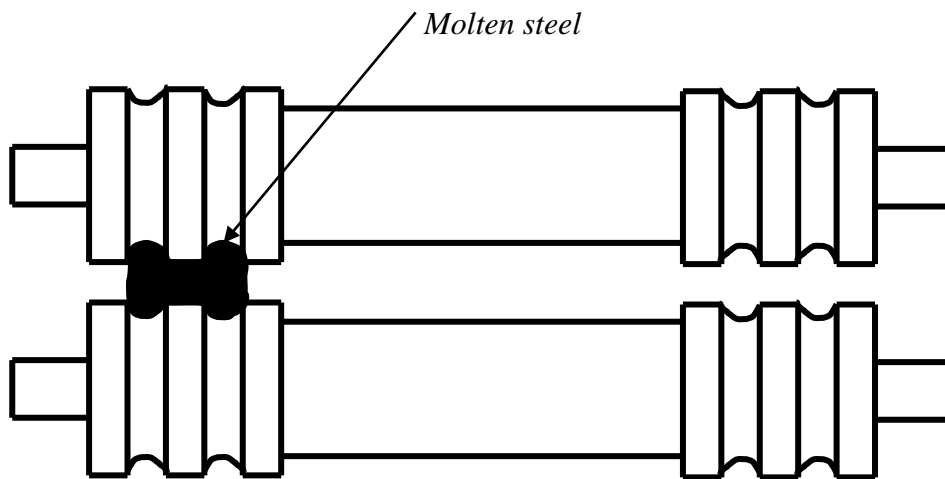

Fig.26 Primary rolls for structural shapes

6.4 Steel Products

The long products are normally used in the as-hot-rolled condition. Plates are used in hot rolled condition as well as in the normalised condition to improve their mechanical properties particularly the ductility and the impact toughness.

The structural sections produced in India include beams (classified as, light, junior, medium and heavy – defined as ISLB, ISJB, ISMB and ISHB respectively) angles (equal, unequal), channel, tees etc. Channel sections are designated as ISLC, ISMC etc. and angles are designated as ISA. Usually the member is designated along with its depth. For example ISMB 300 (300 mm depth), ISMC 250 (250 mm depth), ISA(60 x 60 x 6) (1st leg breadth x 2nd leg breadth x thickness) etc. Sheet products after cold rolling has high strength but very poor ductility. This product needs to be annealed at 650-680°C in the hood annealing furnaces to improve its ductility.

Cold forming is done by passing the hot or cold rolled and annealed product through a series of cold forming rolls.

Now-a-days hollow sections are also becoming very popular. Hollow sections i.e. round, square or rectangular are produced either by seamless rolling process or by fusion welding or electric resistance welding after cold forming of HRC/CRC into the desired shape.

7.0 COLD ROLLING AND COLD FORMING

Cold rolling, as the term implies involves reducing the thickness of unheated material into thin sheets by applying rolling pressure at ambient temperature. The common cold rolled products are coils and sheets. Cold rolling results in smoother surface and improved mechanical properties. Cold rolled sheets could be made as thin as 0.3 mm. Cold forming is a process by which the sheets (hot rolled / cold rolled) are folded in to desired section profile by a series of forming rolls in a continuous train of roller sets. Such thin shapes are impossible to be produced by hot rolling. The main advantage of cold-formed sheets in structural application is that any desired shape can be produced. In other words it can be tailor-made into a particular section for a desired member performance. These cold formed sheet steels are basically low carbon steels (<0.1 % carbon) and after rolling these steel are reheated to about 650^0-723^0C and at this stage ferrite is recrystallised and also result in finer grain size. Because of the presence of ferrite, the ductility is enhanced.

8.0 FINISHING PROCESS

After a member is hot rolled into desired shape, a number of other services are available. These services are simply enumerated below.

- ◆ Exact cutting of length
- ◆ Line straightening of beams after rolling
- ◆ Cambering of beams
- ◆ Surface preparation such as shot blasting and application of protective paints
- ◆ Heat treatment of plates such as annealing, quenching, tempering etc.
- ◆ Pickling in acids to remove mill scale for further galvanising

Usually, information about manufacturing tolerances are supplied by the manufacturers. Even though these tolerances have little effect in normal fabrication and structural applications, they have an important effect when they are used in special applications.

9.0 SUMMARY

In this chapter, a historical review of iron and steel has been covered. The metallurgical aspects of steel, which are relevant to the designers involved in structural steelwork, are briefly presented. The mechanical aspects of structural steels have also been discussed. A mention has been made of the special steels such as stainless steels and cold-formed steels. Finally the basic elements of the manufacturing process of steel have been stated.

In brief, different aspects of steel as are important to a structural engineer, have been described.

10. REFERENCES

1. Graham W. Owens and Peter R. Knowles, “Steel designer’s manual”, ELBS Fifth Edition (1994).
2. Adams P.F., Krentz H.A. and Kulak G.L., “Limit state design in structural steel – SI Units”, Canadian Institute of Steel Construction (1979).
3. IS:2062 Steel for general structural purposes – Specification, Fourth Revision (1992).
4. IS:961 Specification for structural steel (High Tensile) , (1962).
5. Robert E. Reed Hill ,” Physical metallurgy principles”, Second Ed., EWP, New Delhi, (1985).
6. IS:1608 Method of tensile testing of steel products (Second Revision) (1995).
7. IS:1757 Method for charpy impact test (V-notch) on metallic material (1988)
8. IS: 8500, Structural steel - Micro alloyed (medium and high strength qualities) - Specification, First Revision (1991).