

<h1>Structural Steel Design Project</h1>  <h2>Calculation Sheet</h2>	Job No:	Sheet <i>1 of 18</i>	Rev
	Job Title: <i>PLATE GIRDER</i>		
	<i>Worked Example - 1</i>		
		Made by SSSR	Date <i>15-04-00</i>
	Checked by <i>PU</i>	Date <i>25-04-00</i>	
<p><b>PROBLEM:</b></p> <p>The girder showed in Fig. E1 is fully restrained against lateral buckling throughout its span. The span is 36 m and carries two concentrated loads as shown in Fig. E1. Design a plate girder.</p> <p>Yield stress of steel, <math>f_y</math> = 250 N/mm<sup>2</sup>  Material factor for steel, <math>\gamma_m</math> = 1.15  Dead Load factor, <math>\gamma_{fd}</math> = 1.35  Imposed load factor, <math>\gamma_{f\lambda}</math> = 1.50</p>  <p style="text-align: center;"><b>Fig. E1 Example plate girder</b></p>			
<p><b>1.0 LOADING</b></p> <p><b>Dead load:</b></p> <p>Uniformly distributed load, <math>w_d</math> = 20 kN/m (Including self-weight)  Concentrated load, <math>W_{1d}</math> = 200 kN  Concentrated load, <math>W_{2d}</math> = 200 kN</p> <p><b>Live load:</b></p> <p>Uniformly distributed load, <math>w_\lambda</math> = 35 kN/m  Concentrated load, <math>W_{1\lambda}</math> = 400 kN  Concentrated load, <math>W_{2\lambda}</math> = 400 kN</p>			

<h1 style="margin: 0;">Structural Steel Design Project</h1> <p style="margin-top: 20px;"><b>Calculation Sheet</b></p>	Job No:	Sheet <i>2 of 18</i>	Rev												
	Job Title: <i>PLATE GIRDER</i>														
	<i>Worked Example - 1</i>														
		Made by SSSR	Date <i>15-04-00</i>												
	Checked by <i>PU</i>	Date <i>25-04-00</i>													
<p><b><u>Factored Loads:</u></b></p> $w' = w_d * \gamma_{fd} + w_{\lambda} * \gamma_{f\lambda} = 20 * 1.35 + 35 * 1.5 = 79.5 \text{ kN/m}$ $W'_1 = W_{1d} * \gamma_{fd} + W_{1\lambda} * \gamma_{f\lambda} = 200 * 1.35 + 400 * 1.5 = 870 \text{ kN}$ $W'_2 = W_{2d} * \gamma_{fd} + W_{2\lambda} * \gamma_{f\lambda} = 200 * 1.35 + 400 * 1.5 = 870 \text{ kN}$ <p><b>2.0 BENDING MOMENT AND SHEAR FORCE</b></p> <table border="1" style="width: 100%; border-collapse: collapse; margin-top: 10px;"> <thead> <tr> <th style="width: 30%;"></th> <th style="width: 40%; text-align: center;"><i>Bending moment (kN-m)</i></th> <th style="width: 30%; text-align: center;"><i>Shear force (kN)</i></th> </tr> </thead> <tbody> <tr> <td style="text-align: center;"><b>UDL effect</b></td> <td style="text-align: center;"><math>\frac{w^1 \lambda^2}{8} = \frac{79.5 * 36 * 36}{8} = 12879</math></td> <td style="text-align: center;"><math>\frac{w^1 \lambda}{2} = 1431</math></td> </tr> <tr> <td style="text-align: center;"><b>Concentrated load effect</b></td> <td style="text-align: center;"><math>\frac{W \lambda}{4} = 870 * 9 = 7830</math></td> <td style="text-align: center;"><math>W = 870</math></td> </tr> <tr> <td style="text-align: center;"><b>TOTAL</b></td> <td style="text-align: center;"><b>20709</b></td> <td style="text-align: center;"><b>2301</b></td> </tr> </tbody> </table> <p>The design shear forces and bending moments are shown in Fig. E2.</p> <p><b>3.0 INITIAL SIZING OF PLATE GIRDER</b></p> <p><b><u>Depth of the plate girder:</u></b></p> <p>The recommended span/depth ratio for simply supported girder varies between 12 for short span and 20 for long span girder. Let us consider depth of the girder as 2400 mm.</p> $\frac{\lambda}{d} = \frac{36000}{2400} = 15.0$ <p>Depth of 2400 mm is acceptable.</p>					<i>Bending moment (kN-m)</i>	<i>Shear force (kN)</i>	<b>UDL effect</b>	$\frac{w^1 \lambda^2}{8} = \frac{79.5 * 36 * 36}{8} = 12879$	$\frac{w^1 \lambda}{2} = 1431$	<b>Concentrated load effect</b>	$\frac{W \lambda}{4} = 870 * 9 = 7830$	$W = 870$	<b>TOTAL</b>	<b>20709</b>	<b>2301</b>
	<i>Bending moment (kN-m)</i>	<i>Shear force (kN)</i>													
<b>UDL effect</b>	$\frac{w^1 \lambda^2}{8} = \frac{79.5 * 36 * 36}{8} = 12879$	$\frac{w^1 \lambda}{2} = 1431$													
<b>Concentrated load effect</b>	$\frac{W \lambda}{4} = 870 * 9 = 7830$	$W = 870$													
<b>TOTAL</b>	<b>20709</b>	<b>2301</b>													

<h1>Structural Steel Design Project</h1> <p>Calculation Sheet</p>	Job No:	Sheet 3 of 18	Rev
	Job Title: <i>PLATE GIRDER</i>		
	<i>Worked Example - 1</i>		
	Made by	SSSR	Date 15-04-00
Checked by	PU	Date 25-04-00	

*(For drawing the bending moment and shear force diagrams, factored loads are considered)*

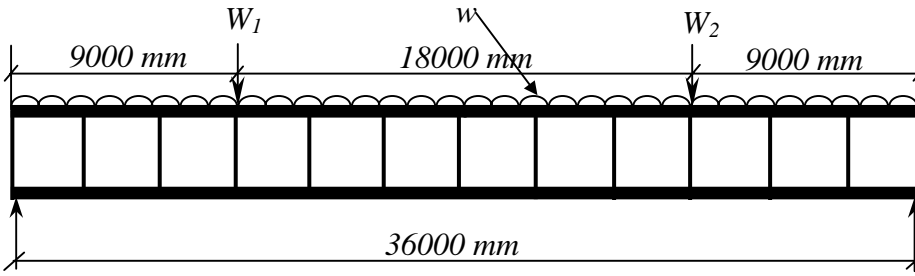
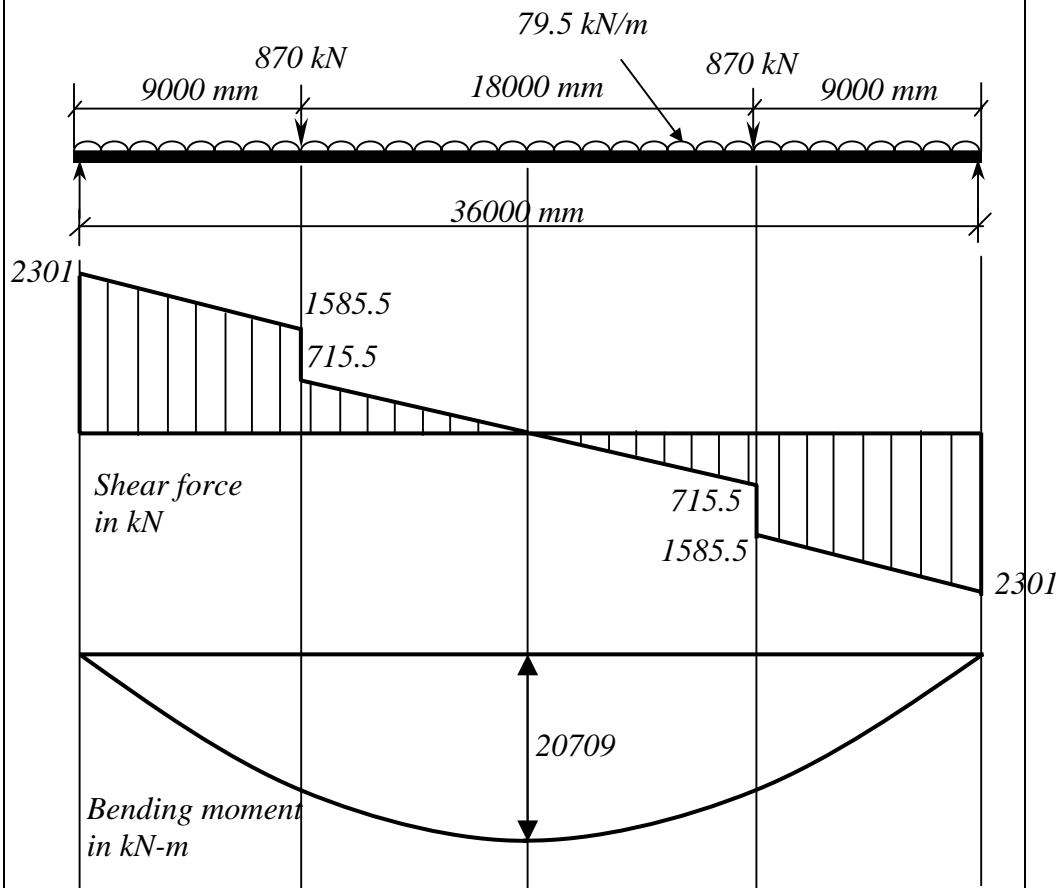

**Fig. E2 Bending moment and shear force diagrams**

<h1>Structural Steel Design Project</h1>  <h2>Calculation Sheet</h2>	Sheet <i>4 of 18</i>	Rev
	Job Title: <i>PLATE GIRDER</i>	
	<i>Worked Example - 1</i>	
	Made by <i>SSSR</i>	Date <i>15-04-00</i>
	Checked by <i>PU</i>	Date <i>25-04-00</i>
<p><b><u>Flange:</u></b></p> <p><math>p_y = 250/1.15 = 217.4 \text{ N/mm}^2</math></p> <p>Single flange area,</p> $A_f = \frac{M_{\max}}{d p_y} = \frac{20709 \cdot 10^6}{2400 \cdot 217.4} = 39690.7 \text{ mm}^2$ <p>By thumb rule, the flange width is assumed as 0.3 times the depth of the section. Try 720 X 60 mm, giving an area = 43200 mm<sup>2</sup>.</p> <p><b><u>Web:</u></b></p> <p>Minimum web thickness for plate girder in buildings usually varies between 10 mm to 20 mm. Here, thickness is assumed as 14 mm.</p> <p>Hence, web size is 2400 X 14 mm</p> <p><b>4.0 SECTION CLASSIFICATION</b></p> <p><b><u>Flange:</u></b></p> $\varepsilon = \left\{ \frac{250}{f_y} \right\}^{\frac{1}{2}} = \left\{ \frac{250}{250} \right\}^{\frac{1}{2}} = 1.0$ $b = \frac{B-t}{2} = \frac{720 - 14}{2} = 353$ $\frac{b}{T} = \frac{353}{60} = 5.9 < 7.9 \varepsilon$ <p>Hence, Flange is <b>PLASTIC SECTION</b>.</p>		

<h1>Structural Steel Design Project</h1>  <h2>Calculation Sheet</h2>	Job No:	Sheet <i>5 of 18</i>	Rev
	Job Title: <i>PLATE GIRDER</i>		
	<i>Worked Example - 1</i>		
		Made by SSSR	Date <i>15-04-00</i>
	Checked by PU	Date <i>25-04-00</i>	
<p><b><u>Web:</u></b></p> $\frac{d}{t} = \frac{2400}{14} = 171.4 > 66.2 \varepsilon$ <p>Hence, the web is checked for shear buckling.</p> <p><b>5.0 CHECKS</b></p> <p><b><u>Check for serviceability:</u></b></p> $\frac{d}{250} = \frac{2400}{250} = 9.6 \text{ mm} < t$ <p>Since, <math>t &gt; \frac{d}{250}</math> Web is adequate for serviceability.</p> <p><b><u>Check for flange buckling in to web:</u></b></p> <p>Assuming stiffener spacing, <math>a &gt; 1.5 d</math></p> $t \geq \frac{d}{294} \left( \frac{p_{yf}}{250} \right)^{1/2} = \frac{2400}{294} \times \left( \frac{217.4}{250} \right)^{1/2} = 7.6 \text{ mm}$ <p>Since, <math>t (= 14 \text{ mm}) &gt; 7.6 \text{ mm}</math>, the web is adequate to avoid flange buckling into the web.</p> <p><b><u>Check for moment carrying capacity of the flanges:</u></b></p> <p>The moment is assumed to be resisted by flanges alone and the web resists shear only.</p> <p>Distance between centroid of flanges, <math>h_s = d + T = 2400 + 60 = 2460 \text{ mm}</math></p> $A_f = B * T = 720 * 60 = 43200 \text{ mm}^2$			

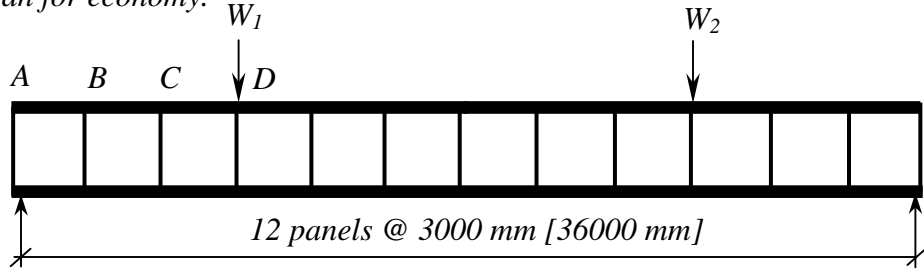
<h1>Structural Steel Design Project</h1>  <h2>Calculation Sheet</h2>	Job No:	Sheet <i>6 of 18</i>	Rev
	Job Title: <i>PLATE GIRDER</i>		
	<i>Worked Example - 1</i>		
		Made by SSSR	Date <i>15-04-00</i>
	Checked by PU	Date <i>25-04-00</i>	
<p><math>M_c = p_{yf} * A_f * h_s = 217.4 * 43200 * 2460 * 10^{-6} = 23103.5 \text{ kN-m}</math>  <math>&gt; 20709 \text{ kN-m}</math></p> <p>Hence, the section is adequate for carrying moment and web is designed for shear.</p> <p><b>6.0 WEB DESIGN</b></p> <p>The stiffeners are spaced as shown in Fig. E5. The spacing of stiffeners is taken as 3000 mm. The spacing can be increased towards the centre of the span for economy.</p>  <p style="text-align: center;"><b>Fig.E3 Trial stiffener arrangement</b></p> <p>Panel AB is the most critical panel (Maximum shear zone), so design checks for the web are made for panel AB only.</p> <p><b><u>End panel ( AB ) design:</u></b></p> <p><math>d = 2400 \text{ mm}</math>  <math>t = 14 \text{ mm}</math>  <math>\frac{a}{d} = \frac{3000}{2400} = 1.25</math></p> <p><math>\frac{d}{t} = \frac{2400}{14} = 171.4</math></p>			

<h1>Structural Steel Design Project</h1>  <h2>Calculation Sheet</h2>	Job No:	Sheet 7 of 18	Rev
	Job Title: PLATE GIRDER		
	Worked Example - 1		
		Made by SSSR	Date 15-04-00
	Checked by PU	Date 25-04-00	
<p><b><u>Calculation of critical shear strength, <math>q_{cr}</math>:</u></b></p> <p>Elastic critical stress, <math>q_e</math> (when <math>a/d &gt; 1</math>) = <math>[1.0 + 0.75/(a/d)^2][1000/(d/t)]^2</math></p> $= [1 + 0.75/(1.25)^2][1000/(171.4)]^2$ $= 50.4 \text{ N/mm}^2$ <p>Slenderness parameter, <math>\lambda_w</math> = <math>[0.6(f_{yw}/\gamma_m)/q_e]^{1/2}</math></p> $= [0.6(250/1.15)/50.4]^{1/2}$ $= 1.61 > 1.25$ <p>Hence, Critical shear strength (<math>q_{cr} = q_e</math>) = <math>50.4 \text{ N/mm}^2</math></p> $f_v = \frac{F_{VA}}{dt} = \frac{2301 \cdot 10^3}{2400 \cdot 14} = 68.5 \text{ N/mm}^2$ <p>Since, <math>f_v &gt; q_{cr}</math> (68.5 &gt; 50.4)</p> <p><b><u>Panel AB is designed using tension field action.</u></b></p> <p><b><u>Calculation of basic shear strength, <math>q_b</math>:</u></b></p> $\phi_t = \frac{1.5q_{cr}}{\sqrt{1 + \left(\frac{a}{d}\right)^2}} = \frac{1.5 \cdot 50.4}{\sqrt{1 + (1.25)^2}} = 47.2$ $y_b = (p_{yw}^2 - 3q_{cr}^2 + \phi_t^2)^{1/2} - \phi_t = (217.4^2 - 3 \cdot 50.4^2 + 47.2^2)^{1/2} - 47.2 = 157.4$ $q_b = q_{cr} + \frac{y_b}{2 \left[ \frac{a}{d} + \sqrt{1 + \left(\frac{a}{d}\right)^2} \right]} = 50.4 + \frac{157.4}{2 \left[ 1.25 + \sqrt{1 + (1.25)^2} \right]} = 78.0 \text{ N/mm}^2$			

<h1>Structural Steel Design Project</h1>  <h2>Calculation Sheet</h2>	Job No:	Sheet <b>8 of 18</b>	Rev
	Job Title: <i>PLATE GIRDER</i>		
	<i>Worked Example - 1</i>		
		Made by SSSR	Date 15-04-00
	Checked by PU	Date 25-04-00	
<p>Since, <math>q_b &gt; f_v</math> (78.0 &gt; 68.5)</p> <p>Panel AB is safe against shear buckling.</p> <p><b><u>Checks for the web panel:</u></b></p> <p>End panel AB should also be checked as a beam (Spanning between the flanges of the girder) capable of resisting a shear force <math>R_{tf}</math> and a moment <math>M_{tf}</math> due to anchor forces. (In the following calculations boundary stiffeners are omitted for simplicity)</p> <p><b><u>Check for shear capacity of the end panel:</u></b></p> $H_q = 0.75 dt p_y \left[ 1 - \frac{q_{cr}}{0.6 p_y} \right]^{1/2} \left[ \frac{f_v - q_{cr}}{q_b - q_{cr}} \right]$ $q_{cr} = 50.4 \text{ N/mm}^2$ $H_q = 0.75 * 2400 * 14 * 217.4 \left[ 1 - \frac{50.4}{0.6 * (250/1.15)} \right]^{1/2} \left[ \frac{68.5 - 50.4}{78 - 50.4} \right] = 2814 \text{ kN.}$ $R_{tf} = \frac{H_q}{2} = \frac{2814}{2} = 1407 \text{ kN}$ $A_v = t \cdot a = 14 * 3000 = 42000 \text{ mm}^2$ $P_v = 0.6 p_{yw} A_v = 0.6 * (250/1.15) * 42000/1000 = 5478 \text{ kN}$ <p>Since, <math>R_{tf} &lt; P_v</math>, the end panel can carry the shear force.</p>			

<h1>Structural Steel Design Project</h1>  <h2>Calculation Sheet</h2>	Job No:	Sheet <b>9 of 18</b>	Rev
	Job Title: <i>PLATE GIRDER</i>		
	<i>Worked Example - 1</i>		
		Made by SSSR	Date <i>15-04-00</i>
	Checked by PU	Date <i>25-04-00</i>	
<p><b><u>Check for moment capacity of end panel AB:</u></b></p> $M_{tf} = \frac{H_q d}{10} = \frac{2814 * 2400}{10} * 10^{-3} = 675.4 \text{ kN} - \text{m}$ $y = \frac{a}{2} = \frac{3000}{2} = 1500$ $I = \frac{1}{12} t a^3 = \frac{1}{12} * 14 * 3000^3 = 3150 * 10^7 \text{ mm}^4$ $M_q = \frac{I}{y} p_y = \frac{3150 * 10^7}{1500} * (250/1.15) * 10^{-6} = 4565 \text{ kN} - \text{m}$ <p>Since, <math>M_{tf} &lt; M_q</math>                      (<math>675.4 &lt; 4565</math>)</p> <p><i>∴ The end panel can carry the bending moment.</i></p> <p><b>7.0 DESIGN OF STIFFENERS</b></p> <p><b><u>Load bearing stiffener at A:</u></b></p> <p><i>Design should be made for compression force due to bearing and moment.</i></p> <p><i>Design force due to bearing, <math>F_b = 2301 \text{ kN}</math></i></p> <p><i>Force (<math>F_m</math>) due to moment <math>M_{tf}</math> is</i></p> $F_m = \frac{M_{tf}}{a} = \frac{675.4}{3000} * 10^3 = 225 \text{ kN}$ <p><i>Total compression = <math>F_c = F_b + F_m = 2301 + 225 = 2526 \text{ kN}</math></i></p>			

<h1>Structural Steel Design Project</h1> <h2>Calculation Sheet</h2>	Job No:	Sheet <i>10 of 18</i>	Rev
	Job Title: <i>PLATE GIRDER</i>		
	<i>Worked Example - 1</i>		
		Made by SSSR	Date <i>15-04-00</i>
	Checked by PU	Date <i>25-04-00</i>	
<p><b><u>Area of stiffener in contact with the flange, A:</u></b></p> <p>Area (A) should be greater than <math>\frac{0.8 F_c}{P_{ys}}</math></p> $\frac{0.8 F_c}{P_{ys}} = \frac{0.8 * 2526}{217.4} * 10^3 = 9295 \text{ mm}^2$ <p>Try stiffener of 2 flats of size 240 X 25 mm thick</p> <p>Allow 15 mm to cope for web/flange weld</p> $A = 225 * 25 * 2 = 11250 \text{ mm}^2 > 9295 \text{ mm}^2$ <p>∴ Bearing check is ok.</p> <p><b><u>Check for outstand:</u></b></p> <p>Outstand from face of web should not be greater than <math>20 t_s \epsilon</math>.</p> $\epsilon = \left\{ \frac{250}{f_y} \right\}^{\frac{1}{2}} = \left\{ \frac{250}{250} \right\}^{\frac{1}{2}} = 1.0$ <p>Outstand <math>b_s = 240 \text{ mm} &lt; 20 t_s \epsilon (= 20 * 25 * 1.0 = 500)</math></p> <p><math>b_s = 240 \text{ mm} &lt; 13.7 t_s \epsilon (= 13.7 * 25 * 1.0 = 342.5)</math></p> <p>Hence, outstand criteria is satisfied.</p>			

<h1>Structural Steel Design Project</h1> <h2>Calculation Sheet</h2>	Job No:	Sheet <i>11 of 18</i>	Rev
	Job Title: <i>PLATE GIRDER</i>		
	<i>Worked Example - 1</i>		
	Made by	SSSR	Date <i>15-04-00</i>
Checked by	PU	Date <i>25-04-00</i>	

**Check stiffener for buckling:** (The effective stiffener section is shown in Fig. E4)

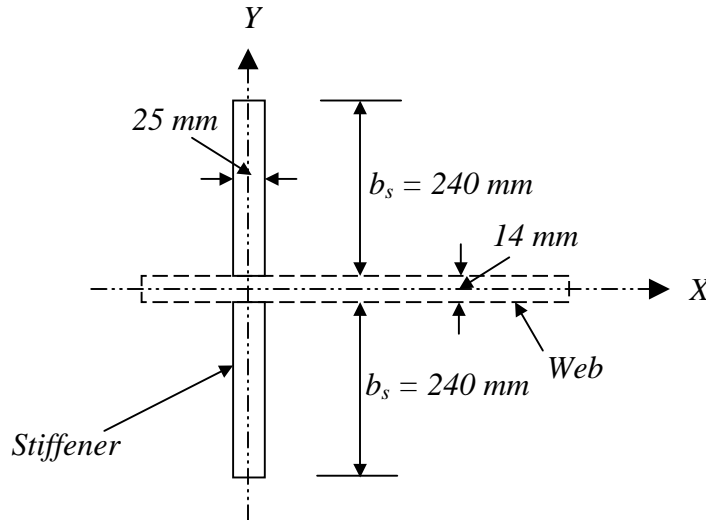

**Fig. E4 End bearing stiffener**

The buckling resistance due to web is neglected here for the sake of simplicity.

$$I_x = \frac{25 \cdot 494^3}{12} - \frac{1}{12} \cdot 25 \cdot 14^3 = 25115 \cdot 10^4 \text{ mm}^4$$

$$A_e = \text{Effective area} = 240 \cdot 25 \cdot 2 = 12000 \text{ mm}^2$$

$$r_x = \left[ \frac{I_x}{A_e} \right]^{1/2} = \left[ \frac{25115 \cdot 10^4}{12000} \right]^{1/2} = 144.7 \text{ mm}$$

Flange is restrained against rotation in the plane of stiffener, then

$$l_e = 0.7 l = 0.7 \cdot 2400 = 1680 \text{ mm}$$

$$\lambda = \frac{l_e}{r_x} = \frac{1680}{144.7} = 11.6$$

<h1>Structural Steel Design Project</h1>  <h2>Calculation Sheet</h2>	Job No:	Sheet <i>12 of 18</i>	Rev
	Job Title: <i>PLATE GIRDER</i>		
	<i>Worked Example - 1</i>		
		Made by SSSR	Date <i>15-04-00</i>
	Checked by PU	Date <i>25-04-00</i>	
<p>For <math>f_y = 250 \text{ N/mm}^2</math> and <math>\lambda = 11.6</math></p> <p><math>\sigma_c = 250 \text{ N/mm}^2</math> from table (3) of chapter on axially compressed columns</p> <p>Buckling resistance of stiffener is</p> $P_c = \sigma_c A_e / \gamma_m = (250/1.15) * 12000 * 10^{-3} = 2609 \text{ kN}$ <p>Since <math>F_c &lt; P_c</math> (<math>2526 &lt; 2609</math>), stiffener provided is safe against buckling.</p> <p><b><u>Check stiffener A as a bearing stiffener:</u></b></p> <p>Local capacity of the web:</p> <p>Assume, stiff bearing length <math>b_1 = 0</math></p> $n_2 = 2.5 * 60 * 2 = 300 \quad \text{BS 5950: Part - 1, Clause 4.5.3}$ $P_{crip} = (b_1 + n_2) t p_{yw}$ $= (0 + 300) * 14 * (250/1.15) * 10^{-3} = 913 \text{ kN}$ <p>Bearing stiffener is designed for <math>F_A</math></p> $F_A = F_c - P_{crip} = 2526 - 913 = 1613 \text{ kN}$ <p>Bearing capacity of stiffener alone</p> $P_A = p_{ys} * A = (250/1.15) * 12000/1000 = 2609 \text{ kN}$ <p>Since, <math>F_A &lt; P_A</math> (<math>1613 &lt; 2609</math>)</p> <p>The designed stiffener is OK in bearing.</p> <p><b><u>Stiffener A</u></b> – Adopt 2 flats 240 mm X 25 mm thick</p>			

<h1>Structural Steel Design Project</h1>  <h2>Calculation Sheet</h2>	Job No:	Sheet <i>13 of 18</i>	Rev
	Job Title: <i>PLATE GIRDER</i>		
	<i>Worked Example - 1</i>		
		Made by <i>SSSR</i>	Date <i>15-04-00</i>
	Checked by <i>PU</i>	Date <i>25-04-00</i>	
<p><b><u>Design of intermediate stiffener at B:</u></b></p> <p><i>Stiffener at B is the most critical intermediate stiffener, hence it will be chosen for the design.</i></p> <p><b><u>Minimum Stiffness:</u></b></p> $I_s \geq 0.75 dt^3 \quad \text{for } a \geq d\sqrt{2}$ $I_s \geq \frac{0.75 dt^3}{a^3} \quad \text{for } a < d\sqrt{2}$ $d\sqrt{2} = \sqrt{2} * 2400 = 3394 \text{ mm}$ $\therefore a < d\sqrt{2} \quad (3000 < 3394)$ <p><i>Conservatively 't' is taken as actual web thickness and minimum 'a' is used.</i></p> $\frac{1.5d^3t^3}{a^2} = \frac{1.5 * 2400^3 * 14^3}{3000^2} = 632 * 10^4 \text{ mm}^4$ <p><i>Try intermediate stiffener of 2 flats 90 mm X 12 mm</i></p> $(I_s)_{\text{Provided}} = \frac{12 * 194^3}{12} - \frac{12 * 14^3}{12} = 730 * 10^4 \text{ mm}^4$ <p><b><u>The section provided satisfies the minimum required stiffness.</u></b></p>			

<h1>Structural Steel Design Project</h1>  <h2>Calculation Sheet</h2>	Job No:	Sheet <i>14 of 18</i>	Rev
	Job Title: <i>PLATE GIRDER</i>		
	<i>Worked Example - 1</i>		
		Made by SSSR	Date <i>15-04-00</i>
	Checked by PU	Date <i>25-04-00</i>	
<p><b><u>Check for outstand:</u></b></p> <p><i>Outstand of the stiffener <math>\leq 13.7 t_s \epsilon</math></i></p> <p><i><math>13.7 t_s \epsilon = 13.7 * 14 * 1.0 = 192 \text{ mm}</math></i></p> <p><i>Outstand = 90 mm (90 &lt; 192)</i></p> <p><i>Hence, outstand criteria is satisfied.</i></p> <p><b><u>Buckling check:</u></b></p> <p><i>Stiffener force, <math>F_q = V - V_s</math></i></p> <p><i>where, <math>V = \text{Total shear force}</math></i>  <i><math>V_s = V_{cr} \text{ of the web.}</math></i></p> <p><i>Elastic critical stress, <math>q_e = 50.4 \text{ N/mm}^2</math></i></p> <p><i><math>V_{cr} = q_{cr} d t = 50.4 * 2400 * 14 * 10^{-3} = 1693 \text{ kN}</math></i></p> <p><i>Shear force at B, <math>V_B = 2301 - [(2301 - 1585.5)*(3000/9000)] = 2062.5 \text{ kN}</math></i></p> <p><i>Stiffener force, <math>F_q = [2062.5 - 1693] = 369.5 \text{ kN}</math></i></p>			

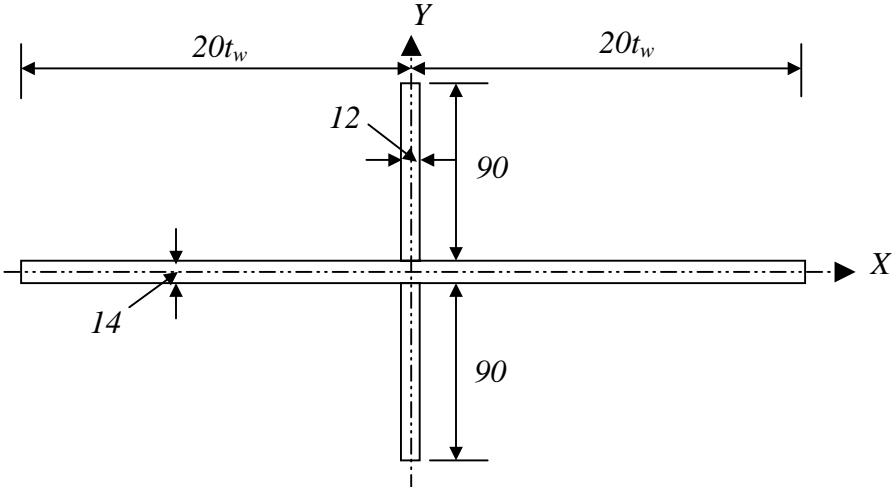
<h1>Structural Steel Design Project</h1> <p>Calculation Sheet</p>	Job No:	Sheet <i>15 of 18</i>	Rev
	Job Title: <i>PLATE GIRDER</i>		
	<i>Worked Example - 1</i>		
		Made by SSSR	Date <i>15-04-00</i>
	Checked by PU	Date <i>25-04-00</i>	
<p><b><u>Buckling resistance of intermediate stiffener at B:</u></b></p>  <p style="text-align: center;"><b>Fig.E5 Effective section</b></p> <p><math>20 t_w = 20 * 14 = 280 \text{ mm}</math></p> $I_x = \frac{1}{12} * 12 * 194^3 + \frac{560 * 14^3}{12} - \frac{12 * 14^3}{12} = 743 * 10^4 \text{ mm}^4$ $A = 180 * 12 + 560 * 14 = 10000 \text{ mm}^2$ $r_x = \left[ \frac{743 * 10^4}{10000} \right]^{1/2} = 27.3$ $l_e = 0.7 * 2400 = 1680$ $\lambda = \frac{l_e}{r_x} = \frac{1680}{27.3} = 61.5$ <p>For <math>f_y = 250 \text{ N/mm}^2</math> and <math>\lambda = 61.5</math></p> <p>From table 3 of chapter on axially compressed columns,</p> $\sigma_c = 182.3 \text{ N/mm}^2$			

<h1>Structural Steel Design Project</h1>  <h2>Calculation Sheet</h2>	Job No:	Sheet <b>16 of 18</b>	Rev
	Job Title: <i>PLATE GIRDER</i>		
	<i>Worked Example - 1</i>		
		Made by SSSR	Date 15-04-00
	Checked by PU	Date 25-04-00	
<p><i>Buckling resistance = <math>(182.3/1.15) * 10000 * 10^{-3} = 1585 \text{ kN}</math></i></p> <p><i><math>F_q &lt; \text{Buckling resistance. } (369.5 &lt; 1585)</math></i></p> <p><i>Hence, intermediate stiffener is adequate</i></p> <p><b><u>Intermediate stiffener at B</u></b> - Adopt 2 flats 90 mm X 12 mm</p> <p><b><u>Intermediate Stiffener at D (Stiffener subjected to external load):</u></b></p> <p><i>Try intermediate stiffener 2 flats 90 mm X 12 mm thick</i></p> <p><b><u>It satisfies the minimum stiffness requirement as in case of stiffener at B.</u></b></p> <p><b><u>Buckling check:</u></b></p> $\frac{F_q - F_x}{P_q} + \frac{F_x}{P_x} + \frac{M_s}{M_{ys}} \leq 1$ <p><math>F_q = V - V_s \quad V = 1585.5 \text{ kN}</math></p> <p><math>V_s = V_{cr} = q_{cr} d t = 50.4 * 2400 * 14 * 10^{-3} = 1693 \text{ kN}</math></p> <p><i><math>F_q</math> is negative and so we can take <math>F_q - F_x = 0</math></i></p> <p><math>M_s = 0</math></p> <p><math>F_x = 870 \text{ kN}</math></p>			

<h1>Structural Steel Design Project</h1>  <h2>Calculation Sheet</h2>	Job No:	Sheet <i>17 of 18</i>	Rev
	Job Title: <i>PLATE GIRDER</i>		
	<i>Worked Example - 1</i>		
		Made by SSSR	Date <i>15-04-00</i>
	Checked by PU	Date <i>25-04-00</i>	
<p><b><u>Buckling resistance of load carrying stiffener at D:</u></b></p> <p><i>(Calculation is similar to stiffener at B)</i></p> <p>Buckling resistance, <math>P_x = (182.3/1.15) * 10000 * 10^{-3} = 1585 \text{ kN}</math></p> <p><math>F_x / P_x = 870/1585 = 0.55 &lt; 1.0</math></p> <p>Hence, stiffener at D is OK against buckling</p> <p><b><u>Stiffener at D</u></b> - Adopt flats 90 mm X 12 mm thick</p> <p><b><u>Web check between stiffeners:</u></b></p> <p><math>f_{ed} \leq p_{ed}</math></p> <p><math>f_{ed} = w^1/t = 79.5/14 = 5.7 \text{ N/mm}^2</math></p> <p>when compression flange is restrained against rotation relative to the web</p> $p_{ed} = \left[ 2.75 + \frac{2}{\left(\frac{a}{d}\right)^2} \right] \frac{E}{\left(\frac{d}{t}\right)^2} = \left[ 2.75 + \frac{2}{\left(\frac{3000}{2400}\right)^2} \right] \frac{200000}{\left(\frac{2400}{14}\right)^2}$ $= \frac{3.79 * 20000}{26406} = 27.4 \text{ N/mm}^2$ <p>Since, <math>f_{ed} &lt; p_{ed}</math> [5.7 &lt; 27.4], the web is OK for all panels.</p>			

<h1>Structural Steel Design Project</h1> <p>Calculation Sheet</p>	Job No:	Sheet <i>18 of 18</i>	Rev
	Job Title: <i>PLATE GIRDER</i>		
	<i>Worked Example - 1</i>		
	Made by	SSSR	Date <i>15-04-00</i>
Checked by	PU	Date <i>25-04-00</i>	

**8.0 FINAL GIRDER**

(All dimensions are in mm)

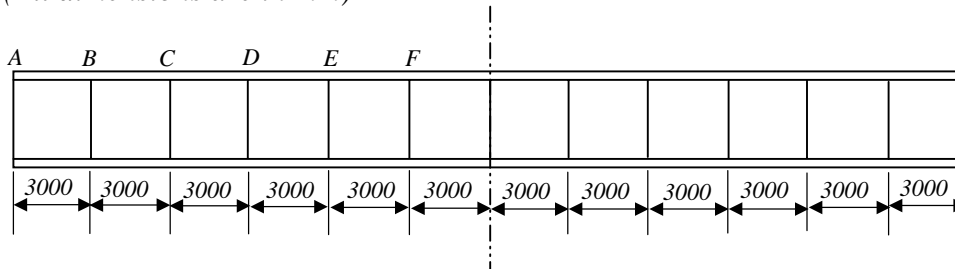

(a) Longitudinal section of plate girder

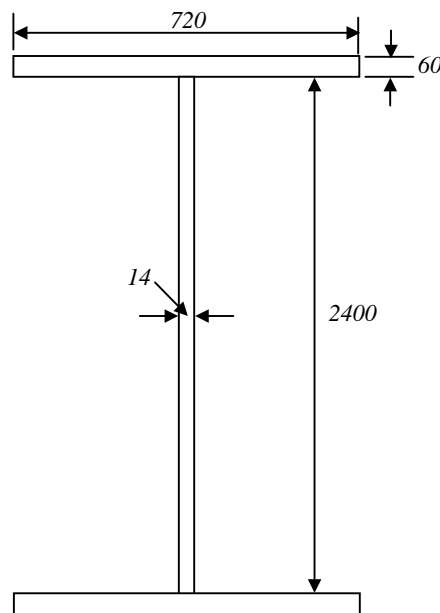

(b) Flange and web proportions

**Fig. E6 Final girder**